

Stanza seeTouch® Keypads
Keypad Base Units
SZA-2WN
SZA-2WDN

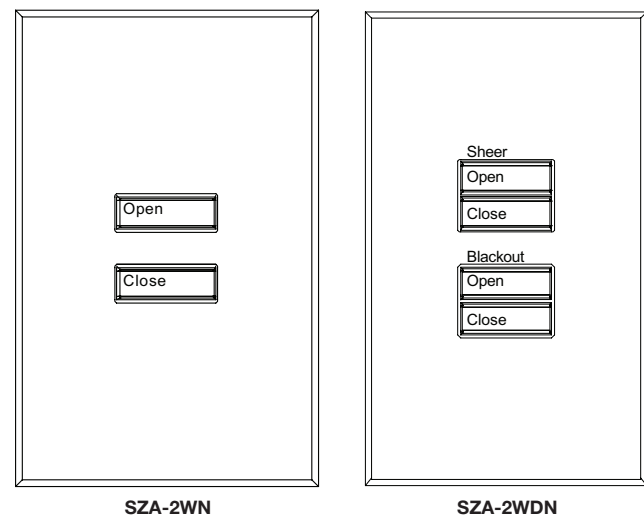

Important Notes
Please read before installing.

Codes: Install in accordance with all local and national electrical codes.

Environment: Ambient operating temperature: 0 °C to 40 °C (32 °F to 104 °F), 0-90% humidity, non-condensing. Indoor use only.

Cleaning: To clean, wipe with a clean damp cloth. Do not use any chemical cleaning solutions.

Faceplates: Must be used with Lutron faceplates. Do not paint controls or faceplates.

Wallboxes: Lutron recommends using a standard U.S. 1-gang wallbox, 2.75 in (70 mm) deep (available from Lutron P/N 241-519)

Keypad Wiring:

Maximum number of Stanza EDU's per Stanza Keypad contact closure output: 4 EDU's

Maximum Wire Length: The maximum wiring distance between a Stanza Keypad and Stanza EDU is 250 ft (75 m)

Wire Type: Three 18-22 AWG (1.00-0.50 mm²) conductors for each pair of Open and Close buttons.

Installation

- 1 Disconnect power to the keypads.**
Turn OFF all circuit breakers connected to the *Stanza Shading System*

WARNING: To avoid the risk of electric shock, locate and lock MCB (supply breaker) in the OFF position or remove fuse. Failure to turn off power can result in personal injury or death.

- 2 Remove faceplate and button kit.**
Remove currently installed faceplate by gently prying from the top.

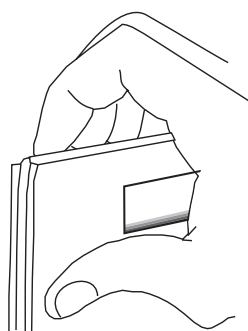

- 3 Keypad Wiring.**
Strip insulation to 3/8 in (10 mm).
Unplug keypad terminal block from the keypad.
Connect wiring to terminal block as shown below. Plug the keypad terminal block back onto the keypad circuit board. Be sure to orient the terminal block correctly.

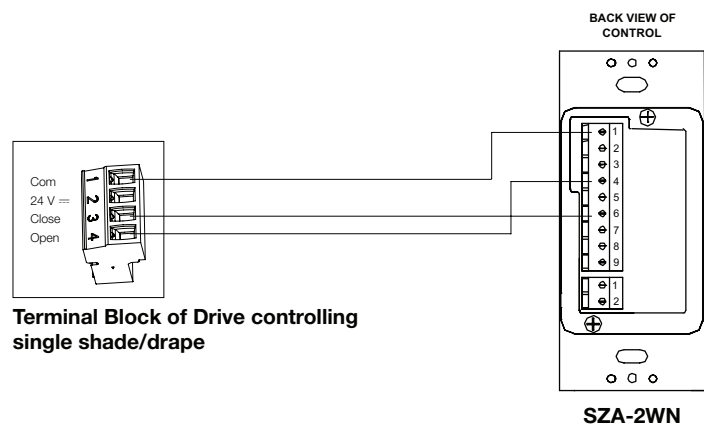

Terminal Block of Drive controlling single shade/drape

- 3 Keypad Wiring. (continued)**

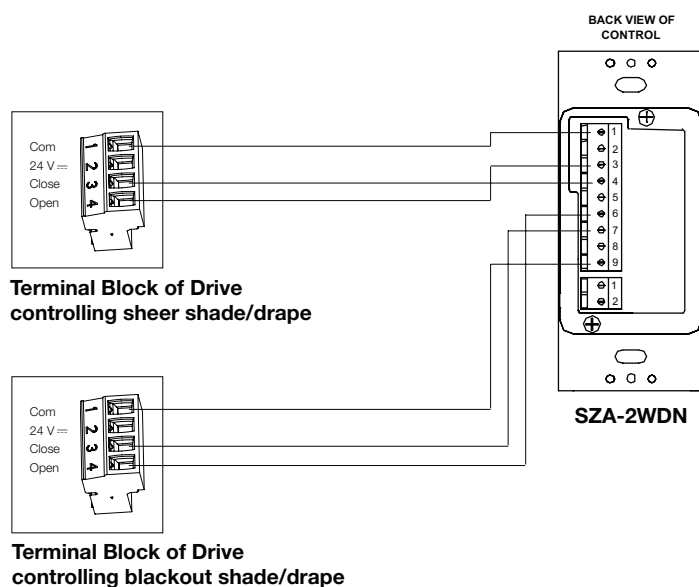

Terminal Block of Drive controlling sheer shade/drape

Terminal Block of Drive controlling blackout shade/drape

- 4 Mount and align Keypad.**

Push all wires back into the wallbox and fasten the control to the wallbox using the screws provided. Do not overtighten. Do not pinch the wires.

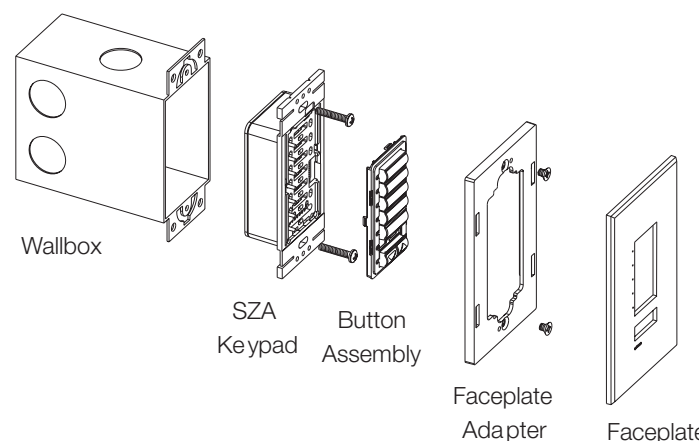

- 5 Turn on power at MCB (circuit breaker) or replace fuse.**

- 6 Troubleshooting**

For information on troubleshooting, please refer to Stanza Shading, wiring and programming guide.

Limited Warranty
SCOPE

This limited warranty ("Warranty") covers the Lutron supplied (a) Stanza® Shade System ("Stanza Shade System"), (b) Stanza® Shade System ("Stanza Shade System"), (c) manual shade system and (d) alternating current or a/c shade system (each of the foregoing being a "System"). Customer acknowledges and agrees that use of the System constitutes acceptance of all terms and conditions of this Warranty.

LIMITED WARRANTY

Subject to the exclusions and restrictions described below, Lutron warrants that each System will be free from manufacturing defects from the date of shipment by Lutron for a period of (a) one year as to the wall controls, interfaces and system accessories of the Stanza Shade System ("External Stanza™ Components") and (b) eight years as to the other Systems and the electronic drive unit, shade fabric and shade hardware of the Stanza Shade System. If any manufacturing defect exists in the External Stanza™ QS Components, so long as Customer promptly notifies Lutron of the defect within the one year warranty period and, if requested by Lutron, returns the defective part(s), Lutron will, at its option, either repair the defective part(s) or provide comparable replacement part(s). If any manufacturing defect exists in any of the components of a System other than the External Stanza Components, so long as Customer promptly notifies Lutron of the defect within the eight year warranty period and, if requested by Lutron, returns the defective part(s), Lutron will, at its option, either repair the defective part(s) or issue a credit to the Customer against the purchase price of comparable replacement part(s) purchased from Lutron as provided below:
Replacement parts for the System provided by Lutron or, at its sole discretion, an approved vendor may be new, used, repaired, reconditioned, and/or made by a different manufacturer.

Number of years from date of shipment	Percentage of cost of replacement parts credited by Lutron
Up to 2	100%
More than 2 but not more than 5	50%
More than 5 but not more than 8	25%
More than 8	0%

EXCLUSIONS AND RESTRICTIONS

This Warranty will be void, and Lutron and its suppliers will have no responsibility under this Warranty, if Lutron or its representatives cannot access any components of the System to inspect, diagnose problems with or repair the System or any of its components as a result of concealment or inaccessibility of such components within a building structure.

This Warranty does not cover, and Lutron and its suppliers are not responsible for:

- Damage, malfunction or inoperability diagnosed by Lutron or a Lutron approved third party as caused by normal wear and tear, abuse, misuse, incorrect installation, neglect, accident, interference or environmental factors, such as (a) use of incorrect line voltages fuses or circuit breakers; (b) failure to install, maintain and operate the System pursuant to the operating instructions provided by Lutron and the applicable provisions of the National Electrical Code and of the Safety Standards of Underwriter's Laboratories; (c) use of incompatible devices or accessories; (d) improper or insufficient ventilation; (e) unauthorized repairs or adjustments or alterations; (f) vandalism; (g) an act of God, such as fire, lightning, flooding, tornado, earthquake, hurricane or other problems beyond Lutron's control; or (h) direct exposure to corrosive materials.
- On-site labor costs to diagnose issues with, and remove, repair, replace, adjust, reinstall and/or reprogram the System or any of its components.
- Components and equipment external to the System, such as, non-Lutron lighting and automation systems; building wiring audio-visual equipment; and non-Lutron time clocks, photosensors and motion detectors.
- The cost of repairing or replacing other property that is damaged when any System does not work properly, even if the damage was caused by the System.

THIS WARRANTY IS IN LIEU OF ALL OTHER EXPRESS WARRANTIES. ALL IMPLIED WARRANTIES, INCLUDING THE IMPLIED WARRANTIES OF MERCHANTABILITY AND OF FITNESS FOR A PARTICULAR PURPOSE, ARE LIMITED TO EIGHT YEARS FROM THE DATE OF SHIPMENT, EXCEPT THAT SUCH IMPLIED WARRANTIES ARE LIMITED TO ONE YEAR FROM THE DATE OF SHIPMENT AS TO THE EXTERNAL Stanza COMPONENTS. NO LUTRON AGENT, EMPLOYEE OR REPRESENTATIVE HAS ANY AUTHORITY TO BIND LUTRON TO ANY AFFIRMATION, REPRESENTATION OR WARRANTY CONCERNING THE SYSTEMS.

UNLESS AN AFFIRMATION, REPRESENTATION OR WARRANTY MADE BY AN AGENT, EMPLOYEE OR REPRESENTATIVE IS SPECIFICALLY INCLUDED HEREIN, OR IN STANDARD PRINTED MATERIALS PROVIDED BY LUTRON, IT DOES NOT FORM A PART OF THE BASIS OF ANY BARGAIN BETWEEN LUTRON AND CUSTOMER AND WILL NOT IN ANY WAY BE ENFORCEABLE BY CUSTOMER.

IN NO EVENT WILL LUTRON OR ANY OTHER PARTY BE LIABLE FOR EXEMPLARY, CONSEQUENTIAL, INCIDENTAL OR SPECIAL DAMAGES (INCLUDING, BUT NOT LIMITED TO DAMAGES FOR PERSONAL INJURY, FAILURE TO MEET ANY DUTY, INCLUDING OF GOOD FAITH OR REASONABLE CARE, NEGLIGENCE, OR ANY OTHER LOSS WHATSOEVER), NOR FOR ANY REPAIR WORK UNDERTAKEN WITHOUT LUTRON'S PRIOR WRITTEN CONSENT ARISING OUT OF OR IN ANY WAY RELATED TO THE INSTALLATION, DEINSTALLATION, USE OF OR INABILITY TO USE THE SYSTEM OR OTHERWISE UNDER OR IN CONNECTION WITH ANY PROVISION OF THIS WARRANTY, EVEN IN THE EVENT OF THE FAULT, TORT (INCLUDING NEGLIGENCE), STRICT LIABILITY, BREACH OF CONTRACT OR BREACH OF WARRANTY OF LUTRON OR ANY OTHER PARTY, AND EVEN IF LUTRON OR SUCH OTHER PARTY WAS ADVISED OF THE POSSIBILITY OF SUCH DAMAGES NOTWITHSTANDING ANY DAMAGES THAT CUSTOMER MIGHT INCUR FOR ANY REASON WHATSOEVER (INCLUDING, WITHOUT LIMITATION, ALL DIRECT DAMAGES AND ALL DAMAGES LISTED ABOVE), THE ENTIRE LIABILITY OF LUTRON AND OF ALL OTHER PARTIES UNDER THIS WARRANTY ON ANY CLAIM FOR DAMAGES ARISING OUT OF OR IN CONNECTION WITH THE MANUFACTURE, SALE, INSTALLATION, DELIVERY, USE, REPAIR, OR REPLACEMENT OF THE SYSTEM, AND CUSTOMER'S SOLE REMEDY FOR THE FOREGOING, WILL BE LIMITED TO THE AMOUNT PAID BY CUSTOMER FOR THE SYSTEM. THE FOREGOING LIMITATIONS, EXCLUSIONS AND DISCLAIMERS WILL APPLY TO THE MAXIMUM EXTENT ALLOWED BY APPLICABLE LAW, EVEN IF ANY REMEDY FAILS ITS ESSENTIAL PURPOSE.

THIS WARRANTY GIVES YOU SPECIFIC LEGAL RIGHTS. YOU MAY ALSO HAVE OTHER RIGHTS WHICH VARY FROM STATE TO STATE. SOME STATES DO NOT ALLOW LIMITATIONS ON HOW LONG AN IMPLIED WARRANTY LASTS OR THE EXCLUSION OR LIMITATION OF INCIDENTAL OR CONSEQUENTIAL DAMAGES, SO THE ABOVE LIMITATIONS OR EXCLUSIONS MAY NOT APPLY TO YOU. WARRANTY CLAIMS, TECHNICAL ASSISTANCE AND WARRANTY INFORMATION.
Contact the Lutron Technical Support Center at the numbers provided below or your local Lutron sales representative with questions concerning the installation or operation of the System or this Warranty, or to make a warranty claim. Please provide the exact model number when calling.

The product may be covered under one or more of the following U.S. patents: D456,783; and corresponding patents pending. U.S. and foreign patents pending. Lutron and the Sunburst logo are registered trademarks, and Stanza is a trademark of Lutron Electronics Co., Inc.

Worldwide Headquarters | USA

Lutron Electronics Co., Inc.
7200 Suter Road
Coopersburg, PA 18036-1299 USA
TEL: 1.610.282.3800
FAX: 1.610.282.3090
Technical Support: 1.800.523.9466 or 1.610.282.6701
Toll Free: 1.888.LUTRON
EMAIL: shadinginfo@lutron.com
WEB: www.lutron.com/shadingsolutions

Europe Headquarters | United Kingdom

Lutron EA Ltd
6 Sovereign Close
London, E1W 3JF, UK
TEL: +44.(0)20.7702.0657
FAX: +44.(0)20.7480.6899
Technical Support: +44.(0)20.7480.6899
FREEPHONE: 0800.282.107

Asian Headquarters | Singapore

Lutron GL Ltd
15 Hoe Chiang Road
#07-03
Singapore, 089316
TEL: +65.6220.4666
FAX: +65.6220.4333
Technical Support: 800.120.4491