

Hi-POWER 2•4•6™

Installation Instructions

Please Leave for Occupant

HP-2, HP-4, & HP-6

Dimming Module

120/277VAC, 60Hz

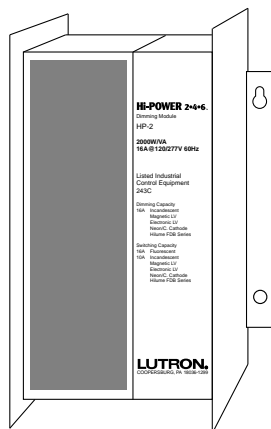

Description

The Hi-POWER 2•4•6 Dimming Module provides the capability to control a large zone of lighting from either a Lutron incandescent wallbox dimmer or from Class 2 controls. Multiple modules can be used together in a system to control a total load of up to 30,000W/VA. The Hi-POWER 2•4•6 Dimming Module can dim 120V incandescent, magnetic low-voltage, electronic low-voltage, neon/cold-cathode loads, 277V magnetic low-voltage, and Lutron's Hi-lume® FDB-series and Eco-10™ 120V and 277V fluorescent dimming ballasts. It can also switch these loads (except Hi-lume FDB and Eco-10 ballasts) as well as metal halide and non-capacitive fluorescent loads.

Important Notes

Please Read Before Installation

1. Install in accordance with all local and national electrical codes.
2. **CAUTION:** Only a qualified electrician should install this system. Turn power OFF at circuit breakers or remove fuses before wiring. Do not wire with power on. Improper wiring can result in personal injury or damage to equipment. Damage to product caused by wiring with power on voids warranty.
3. Do not remove factory-installed bypass jumpers on load circuit terminals until load circuits are tested (see Start-up Procedure on page 5).
4. The Hi-POWER dimming modules are designed to operate in ambient temperatures between 0°C-40°C (32°F-104°F).
5. To reduce the risk of overheating and possible damage to other equipment, the module must be mounted as shown on page 2. Failure to provide adequate space for cooling may result in overheating and void the warranty.

6. Module hums slightly during operation and the internal relay clicks when the circuit is turned on and off. Choose an installation location where these sounds are acceptable.
7. Operation of dimmed low-voltage circuit with all lamps inoperative or removed may result in current flow in excess of normal levels. To avoid transformer overheating and possible failure, Lutron strongly recommends the following:
 - a. Do not operate dimmed low-voltage circuits without lamps in place.
 - b. Replace burned-out lamps immediately.
 - c. Use transformers incorporating thermal protection or fused transformer primary windings to prevent transformer failure due to overcurrent.
8. Dimmed electronic low-voltage transformers may produce an audible noise when dimmed. For more information, call the toll-free **Lutron Hotline** at 1-800-523-9466.
9. See "Neon/Cold-Cathode Dimming" (pages 14-15) before attempting to dim neon/cold-cathode lamps.
10. For proper dimming performance fluorescent lamps must be operated at full intensity for 100 hours prior to dimming.

Electrical Ratings

Module		HP-2	HP-4	HP-6
Inputs Required	Control Circuit 120VAC, 60Hz	1 (20VA)	1 (20VA)	1 (20VA)
	Load Circuit 120/277 ^{1,4} VAC, 60Hz	1	2	3
Outputs Available	Dimmed Hot	1	2	3
	Switched Hot	1	2	3
Minimum load per Module	Hi-lume FDB or Eco-10 ballasts	1	2	3
	All other loads	50W/VA	100W/VA	150W/VA
Heat Dissipation	BTU/Hr			
	Maximum	200	400	600

Capacity of each Output ^{2,3}

Load Type	Dimmed	Switched ⁴
Incandescent	16A (1920W)	10A
Magnetic Low-Voltage, Electronic Low-Voltage, or Neon/Cold-Cathode	16A (1920VA)	10A
Hi-lume FDB or Eco-10 Fluorescent	16A	—
Fluorescent (non-capacitive)	—	16A
Metal Halide	—	10A

¹ 277V Hi-lume FDB or Eco-10 fluorescent, or 277V magnetic low-voltage only.

² Any load circuit can be connected to any phase.

³ Each load circuit may be connected to a different load type; however, load types cannot be mixed on the same circuit.

⁴ Switched loads may be either 120 or 277VAC.

LUTRON®

These products may be covered by one or more of the following U.S. patents: 4,797,599; 4,803,380; 4,893,062; 4,947,054; 5,030,893; 5,191,265; 5,248,919; 5,399,940; 5,430,356; 5,463,286; DES 311,170; DES 313,738; DES 337,755; DES 399,326; DES 344,264; DES 353,798 and corresponding foreign patents. U.S. and foreign patents pending. Lutron, GRAFIK Eye, Hi-lume, Maestro, Nova T*, and Vareo are registered trademarks and Hi-POWER 2•4•6, ECO-10, and Omnislide are trademarks of Lutron Electronics Co., Inc. © 1996 Lutron Electronics Co., Inc.

Mounting and Dimensions

- 1. Choose an appropriate location.**
 Select a convenient location such as an electrical closet or basement. Make sure location is at least 6' from sensitive equipment (and its wiring). Also, make sure to locate module where its sounds (relays clicking and slight humming) are acceptable. Ensure ambient temperatures are between 0°C-40°C (32°F-104°F). Module must be mounted away from steam pipes, direct sunlight, or other heat sources.
- 2. Plan placement of modules (see below).**
 Modules must be mounted vertically. Make sure nothing blocks the air channel between the back of the module and the wall.
 - Leave 6" (152mm) of space above and below modules and 3" (76mm) of space on either side of modules.
 - Leave 10" (204mm) between the top of the module and the ceiling, and 6" (152mm) between the bottom of the module and the floor.
 - Leave 6" (152mm) of clearance in front of each module.

- 3. Mount modules (see below).**
 Using the mounting dimensions shown below, mark (while keeping the module vertical), then drill mounting holes. Securely fasten the module to the wall. Mounting holes are keyed to facilitate mounting.

Airspace Required

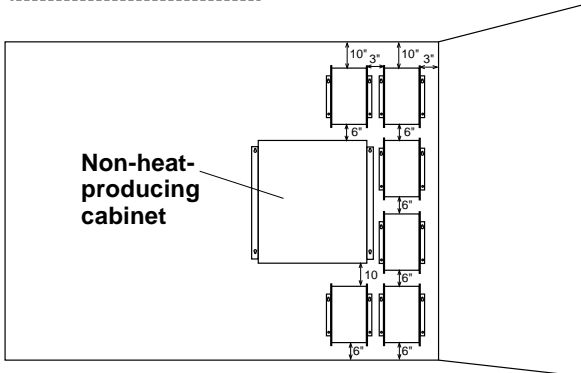
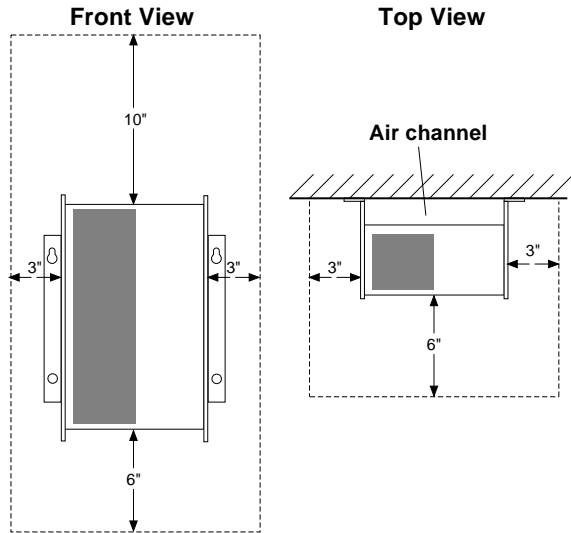

Mounting Dimensions

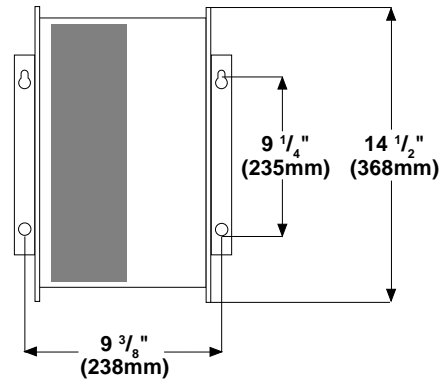

Knockout Locations

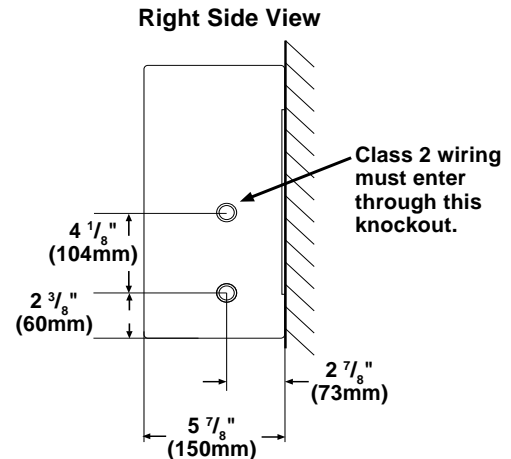
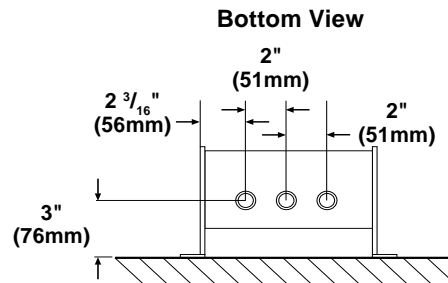

Wiring



WARNING: Turn power OFF to all circuits before installing any part of the Dimming System. Wiring with the power on can result in serious personal injury or damage to equipment.

1. Pull dedicated feeds.

For each circuit in the Hi-POWER module, pull a 20A dedicated feed: one circuit for the HP-2, two circuits for the HP-4, and three circuits for the HP-6 (see Typical System Wiring Diagram).

2. Provide control circuit power to first module.

The Hi-POWER module requires power to operate its circuitry. This control circuit can be wired from any of the dedicated feeds coming into the Hi-POWER module as long as they have an additional 20VA of capacity available for each Hi-Power module connected to the same control (refer to Power Feed Wiring Diagram on page 4 for terminal locations). Do not wire control circuit power to any additional modules.



IMPORTANT: If more than one module is used, only connect power to the control circuit of the first module.

For GRAFIK Eye systems, the control circuit must be on the same phase as the circuit for the GRAFIK Eye Control Units. Lutron recommends pulling the control circuit from the GRAFIK Eye Control Unit's feed circuit if 20VA additional capacity per Hi-POWER module is available. Alternately, power may be provided to the control circuit from any circuit with an excess capacity of 20VA per Hi-POWER module as long as the circuit is on the same phase as the GRAFIK Eye Control Unit (see Control Wiring Diagram 13 on page 11 for more information).

3. Wire between Hi-POWER modules.

If more than one Dimming Module is being operated from the same control, run 3 #12 wires from the Additional Module Terminals on the first module to the Additional Module Terminals on the next. No connection is made to the Control Circuit Terminals on the additional modules. Wire additional modules until all are connected in a line. See Power Feed Wiring Diagram on page 4 for location of the Additional Module Terminals. Wiring is 1 to 1, 2 to 2, 3 to 3. Do not cross wires.

Typical System Wiring Diagram

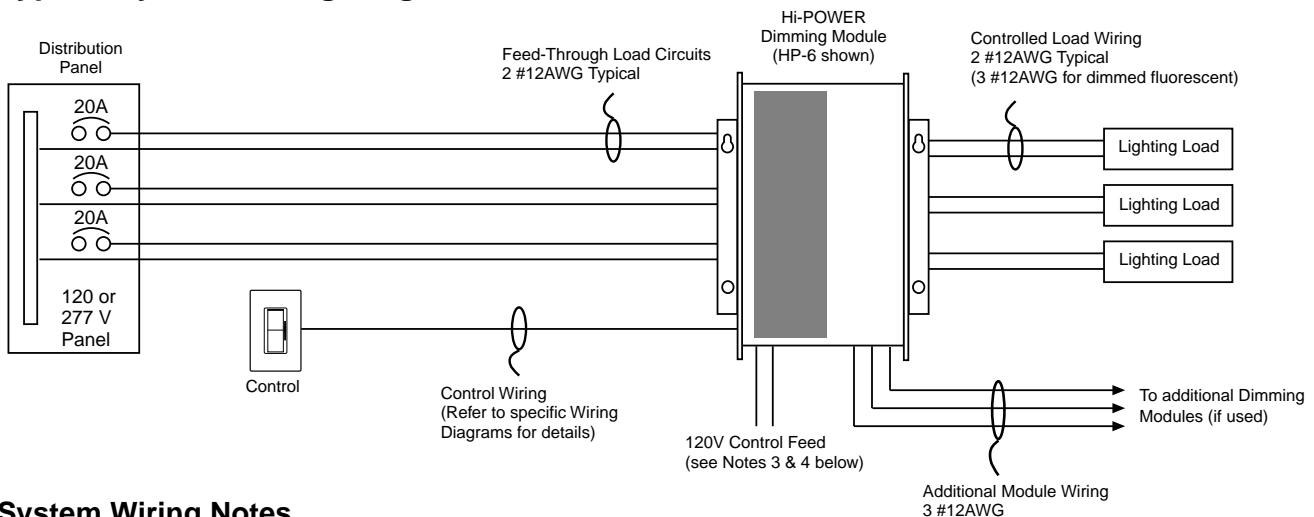

System Wiring Notes

1. Load circuit input feeds can be connected to any phase.
2. Power and control wires must be run in separate raceways. Run individual neutrals for each input and load circuit.
3. Module requires a 120V control circuit input feed. It can be provided from any source, such as one of the load circuits, with 20VA of spare capacity for each Hi-POWER module in the system (For GRAFIK Eye 3000, the control circuit feed must be on same phase as the power for the GRAFIK Eye Control Unit.) If necessary, a 277:120V, 100VA transformer may be used to obtain proper input. (Examples are Acme #TA-2-81303, Hammond Mfg. #MH100GP, or equivalents.)
4. In systems with more than one dimming module per lighting zone, connect feed to control circuit of first module only. **Control circuits must be 120V only.**
5. The diagram represents a three load circuit model (HP-6). For one circuit (HP-2) or two circuit (HP-4) applications, the number of circuits controlled differs, but the wiring will be the same. A different load type may be used on each circuit if desired. However, do not mix load types on the same load circuit.
6. 15A circuit breakers may be used in place of 20A circuit breakers. Do not exceed 1440W per 15A circuit.

4. Wire to Controlled Loads.

Load wiring differs depending on the load type and whether the load is dimmed or switched (see below). Refer to Load Wiring Diagrams on page 7 for load wiring specifics.

Load Type	Load Wiring Diagram	
	Dimmed	Switched
Incandescent	1	3
Magnetic Low-Voltage	1	3
Electronic Low-Voltage	1	3
Neon/Cold-Cathode	1	3
Hi-lume FDB	2	—
Eco-10	2	—
Fluorescent (non-capacitive)	—	3
Metal Halide	—	3

NOTE: Electronic and magnetic low-voltage transformers may create an audible noise when connected to a dimmer.

5. Wire to Controls.

Control wiring will vary depending on the type of control being used. Refer to the appropriate page for the necessary control wiring:

Control Type	Control Wiring Diagram	Page
Single-pole dimmer*	1	8
Mechanical 3-way dimmer*	2-4	8
Maestro	5-7	9
Vareo	8-10	10
Nova T* Infrared	11	11
Nova T* Omnislide	12	11
GRAFIK Eye 3000	13	11
Class 2 Control (raise/lower)	14	12-13

* Rotary, Glyder, Ariadni, Skylark, Diva, Luméa, Nova T* Slide-to-Off, Nova T* Preset, Nova Slide-to-Off, Nova Preset, Centurion, and Athena.

6. Start-up system.

Go to Start-up Procedure on page 5 to put the dimming system in operation.

Power Feed Wiring Diagram

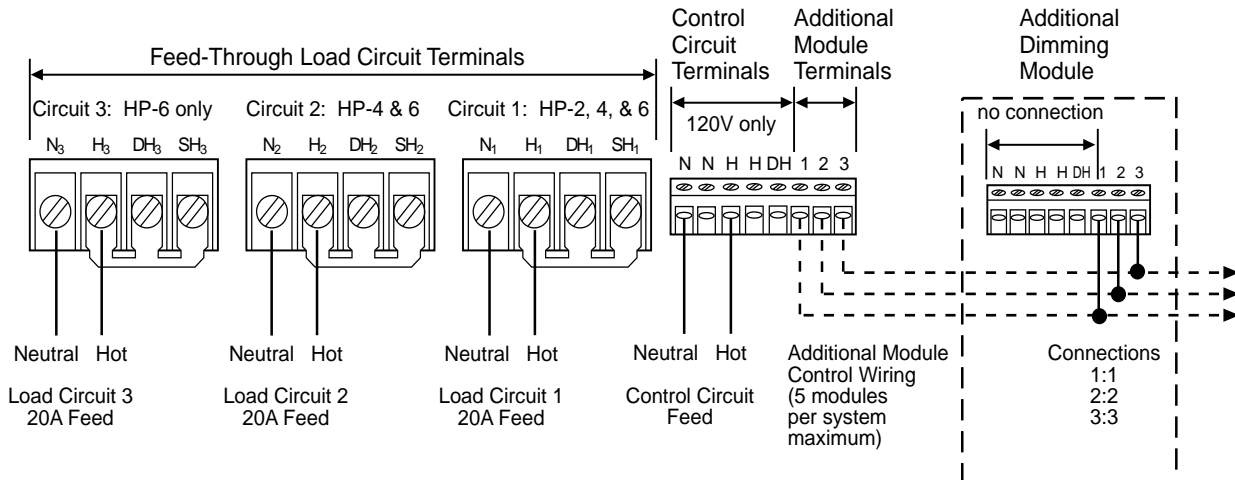
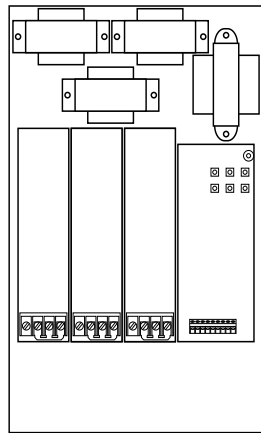

Start-up Procedure

Check Load Circuits.

1. Make sure the factory-installed bypass jumper(s) are still in place between the H (Hot), SH (Switched Hot), and DH (Dimmed Hot) terminals of each load circuit. Replace module cover. Turn circuit breakers on for each load circuit (1 circuit for HP-2, 2 circuits for HP-4, and 3 circuits for HP-6). Each Load Circuit Indicator Light inside the dimming module should light to full intensity.
2. Check the input current to the Hot terminal of each load circuit with a "clamp-on" type current probe. The current should be no more than 16A for dimmed loads or 10A for switched loads (16A for non-capacitive fluorescent). See diagram.
3. Turn loads ON for at least 10 minutes. If any circuit breaker trips, turn power OFF, then locate and correct miswire or overload.
4. Repeat the above steps until the circuit breaker does not trip. If the Hi-POWER module is controlled by a line voltage dimmer, proceed to Check Control Circuit section (next column). If the module is controlled by Class 2 controls, proceed to "Remove Bypass Jumpers" (next column).

Check Control Circuit (line-voltage dimmer only).

1. With power OFF, make sure all control wiring is correct. Replace module cover. Turn circuit breakers ON for each load circuit (one circuit for HP-2, two circuits for HP-4, and three circuits for HP-6) and the control circuit (if wired from a different breaker). Additional dimming modules should not have any wires connected to the control circuit terminals. Each system (circuit and modules) should have only one control circuit wired.

Load Circuit Testing

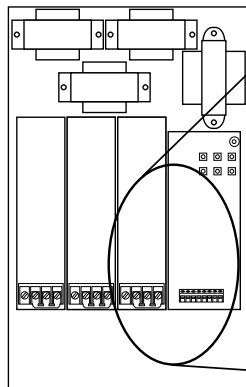

2. Adjust slider/knob/rocker on control, then switch control on and off. The lighting should remain on full, but the control power indicator light should dim up and down and/or switch on or off as the control is adjusted. Make sure the Load Circuit Indicator Lights are not dimming or switching on or off with the control. If they are, control and load wiring are incorrect. Correct wiring errors and repeat Start-up Procedure.

Remove Bypass Jumpers.

1. Turn power OFF. Make sure to remove power from all circuits providing power to the Hi-POWER dimming module.
2. Remove the load circuit bypass jumper(s) from all modules. Do not remove factory-installed jumper from Class 2 terminal block when using Lutron NTRCS-1, NRCS-1, and RCS-1 controls. See wiring diagram on pages 12-13 for details.
3. Turn power ON to all circuits. Test the control(s) to make sure they adjust the light level. The system should now function properly. If not, refer to the Troubleshooting section on page 16.
4. Proceed to Calibration on page 6.

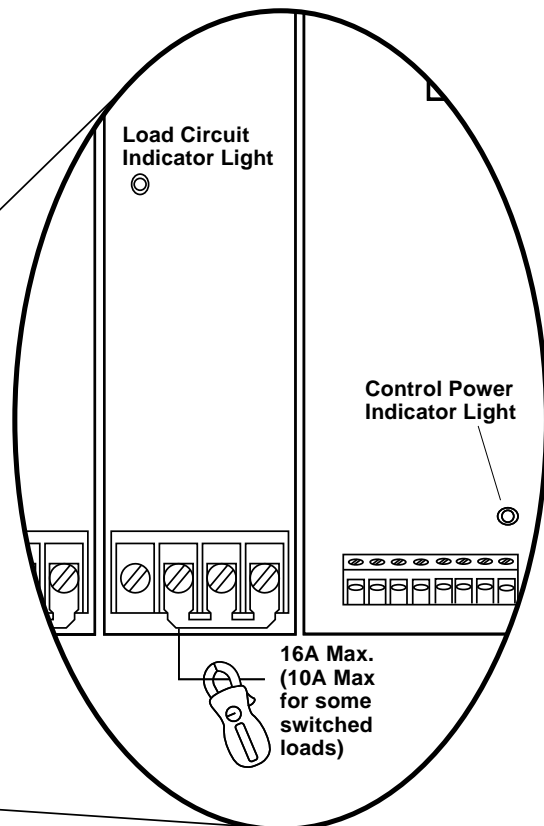

Calibration

High-End and Low-End Trim Adjustment

The high-end and low-end light levels are adjustable to get the best dimming range for the particular application and load type.

- **For Lutron Hi-lume or ECO-10 fluorescent loads:** This unit is factory-calibrated and does not require low-end light adjustment. If lamps flicker or drop out at minimum dimming level there may be an installation error. Continued use of the system in this mode will cause premature lamp failure. If this is occurring, call the **Lutron Hotline** at 1-800-523-9466. For proper dimming performance fluorescent lamps must be operated at full intensity for 100 hours.
- **For incandescent, magnetic low-voltage, and electronic low-voltage loads:** Some adjustment will be necessary to achieve full-range dimming.
- **For neon/cold-cathode loads:** Depending on the installation, you may be able to achieve a lower dimming range. The low-end should be adjusted so that no flickering occurs or the transformer may fail prematurely.

Control Adjustment: Line-voltage incandescent dimmer

CAUTION: For all adjustments, use the supplied non-conductive probe. Failure to do so can result in personal injury or damage to equipment. Do not use screwdriver or finger.

High-End Trim

1. Adjust the wall control to its full intensity position.
2. Using the non-conductive probe, push the small buttons labeled “RAISE” or “LOWER” (see diagram at right) to make the high-end light level brighter or dimmer.
3. Repeat for each load circuit as necessary.

Low-End Trim

1. Adjust the wall control to its minimum position.
2. Using the non-conductive probe, push the small buttons labeled “RAISE” or “LOWER” (see diagram at right) to make the low-end light level brighter or dimmer.
3. Repeat for each load circuit as necessary.

Control Adjustment: Class 2 Raise/Lower

CAUTION: For all adjustments, use the supplied non-conductive probe. Failure to do so can result in personal injury or damage to equipment. Do not use screwdriver or finger.

High-End Trim

1. Using the non-conductive probe, turn the Fade Rate Adjust (see figure below) fully counterclockwise.
2. Activate the raise function on the control for 10 seconds to bring the lights to their maximum intensity.
3. Using the non-conductive probe, push the small buttons labeled “RAISE” or “LOWER” (see figure below) to make the high end light level brighter or dimmer.
4. Repeat for each load circuit as necessary.

Low-End Trim

1. Using the non-conductive probe, turn the Fade Rate Adjust (see figure below) fully counterclockwise.
2. Activate the lower function on the control for 10 seconds to bring the lights to their minimum intensity.
3. Using the non-conductive probe, push the small buttons labeled “RAISE” or “LOWER” to make the low-end light level brighter or dimmer.
4. Repeat for each load circuit as necessary.

Fade Rate Adjustment (Class 2 controls only)

The fade rate is the time it takes for the lights to go from the lowest to highest intensity (or vice-versa) when activating a Class 2 wired raise/lower control. If you are using Class 2 wired NTRCS-1, NRCS-1, or RCS-1 multi-location wall controls, the Hi-POWER module is factory preset to the fastest fade rate. The fade rate can be changed in increments of approximately 2, 4, 8, 15, 30, and 60 seconds. Use the non-conductive probe to turn the Fade Rate Adjust (see figure below) clockwise to fade faster or counterclockwise to fade slower.

Intensity and Fade Adjust Location

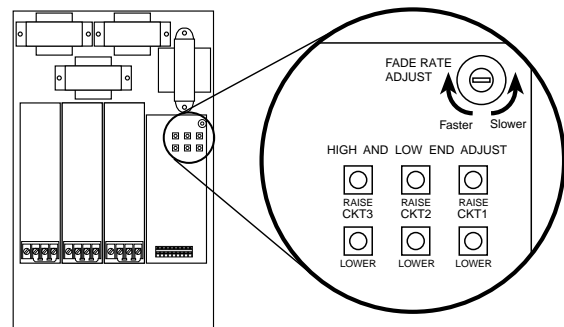

Load Wiring

Diagram 1

Dimmed loads:

Incandescent, Magnetic Low-Voltage, Electronic Low-Voltage, Neon/Cold-Cathode

Wiring notes:

1. For Neon/Cold-Cathode loads, refer to pages 14 and 15 for proper installation.
2. Terminal blocks are rated for 2 #12 AWG max.
3. Load wiring must be 120VAC.
4. The diagrams represent a single load circuit model (HP-2). For two circuit (HP-4) or three circuit (HP-6) applications, repeat the same wiring method for each circuit. A different load type may be used on each circuit if desired. However, do not mix load types on the same load circuit.

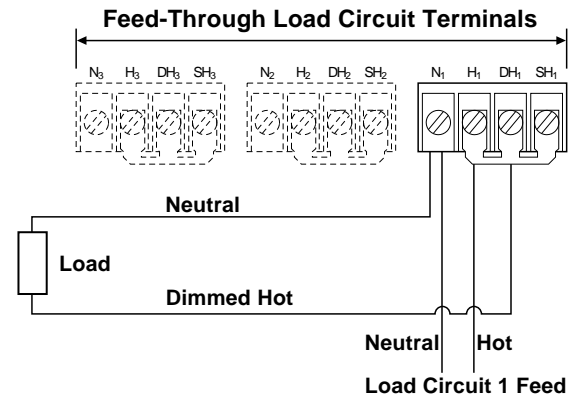

Diagram 2

Dimmed Loads:

Hi-lume FDB and Eco-10 Fluorescent Dimming Ballasts

Wiring notes:

1. Use only Lutron Hi-lume or Eco-10 Fluorescent Dimming Ballasts.
2. Terminal blocks are rated for 2 #12 AWG max.
3. Load wiring may be 120VAC or 277VAC. Control circuit must be 120VAC.
4. The diagrams represent a single load circuit model (HP-2). For two circuit (HP-4) or three circuit (HP-6) applications, repeat the same wiring method for each circuit. A different load type may be used on each circuit if desired. However, do not mix load types on the same load circuit.

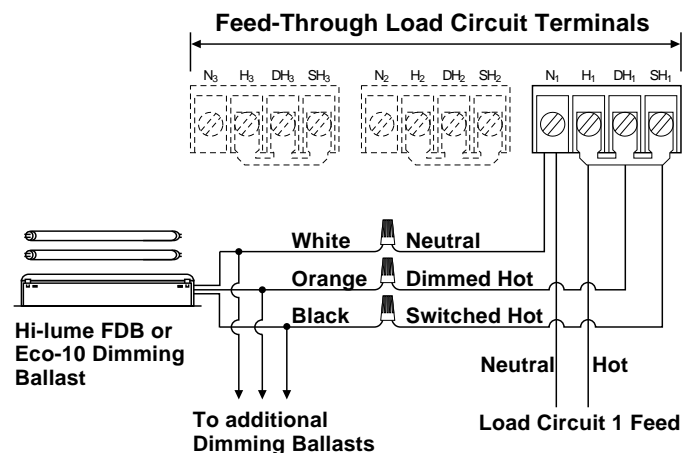

Diagram 3

Switched loads:

Incandescent, Magnetic Low-Voltage, Electronic Low-Voltage, Neon/Cold-Cathode, Non-Capacitive Fluorescent, and Metal Halide

Wiring notes:

1. Terminal blocks are rated for 2 #12 AWG max.
2. Load wiring may be 120VAC or 277VAC. Control circuit must be 120VAC.
3. The diagram represented a single load circuit model (HP-2). For two circuit (HP-4) or three circuit (HP-6) applications, repeat the same wiring method for each circuit. A different load type may be used on each circuit if desired. However, do not mix load types on the same load circuit.

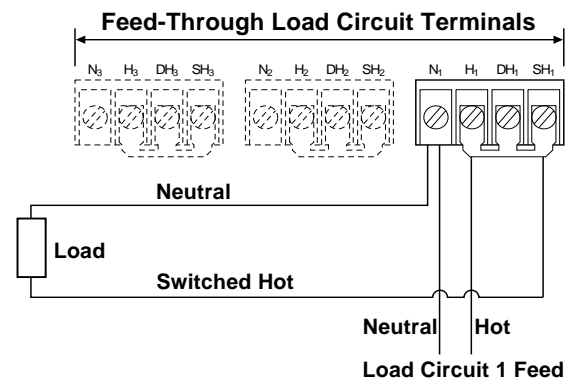

Control Wiring

Diagram 1: Single-pole Dimmer

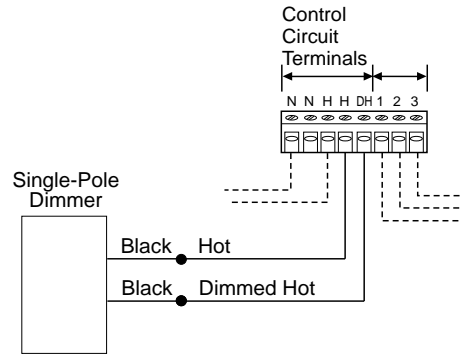

Diagram 2: Mechanical 3-way Dimmer (Single location)

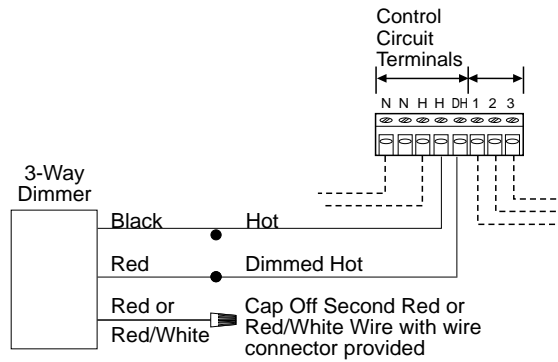

Diagram 3: Mechanical 3-way Dimmer (Two location)

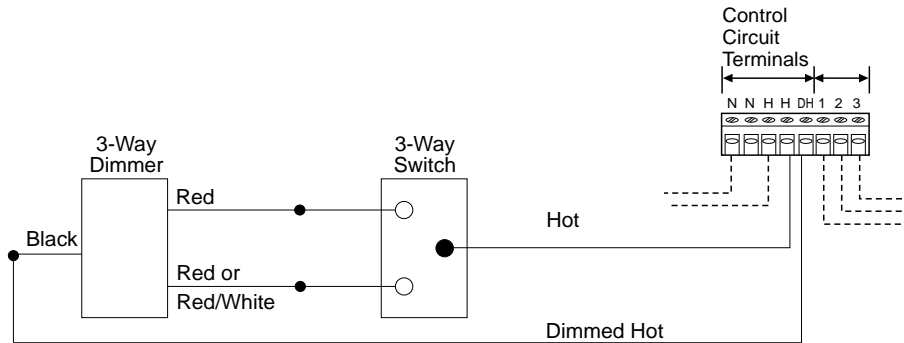
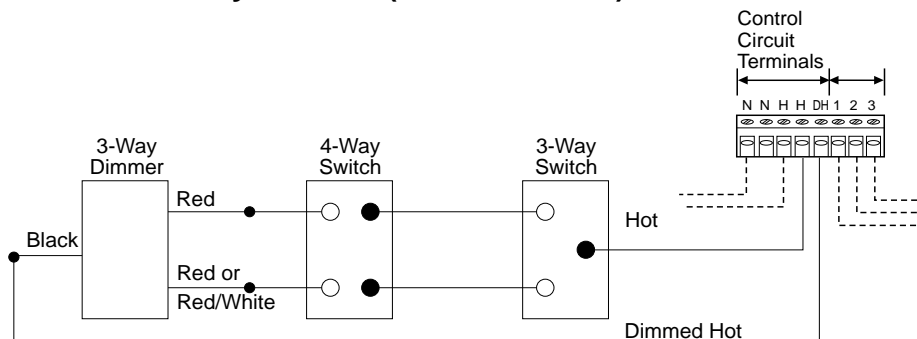

Diagram 4: Mechanical 3-way Dimmer (Three location)



Control Wiring

Diagram 5: Maestro Incandescent Dimmer (Single location)

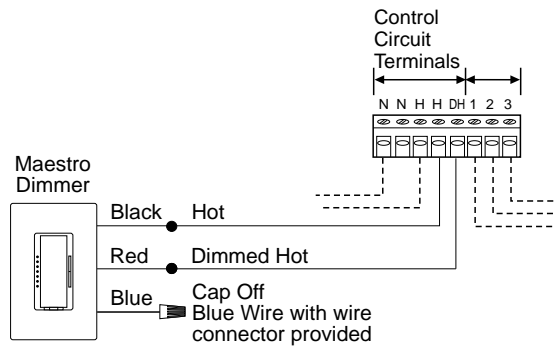

Diagram 6: Maestro Incandescent Dimmer (Two location)

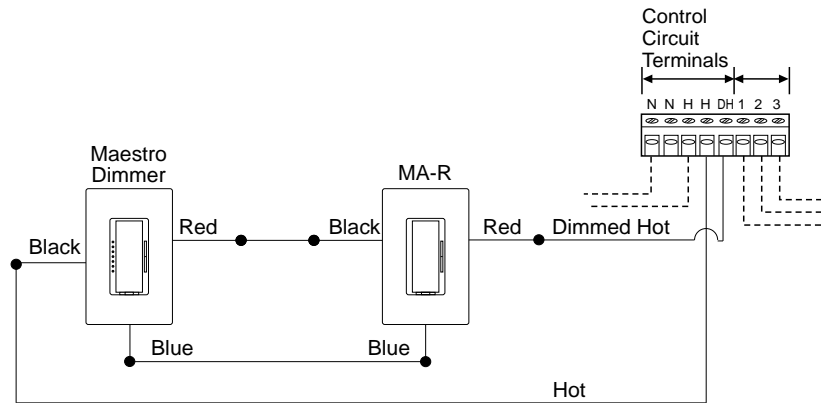
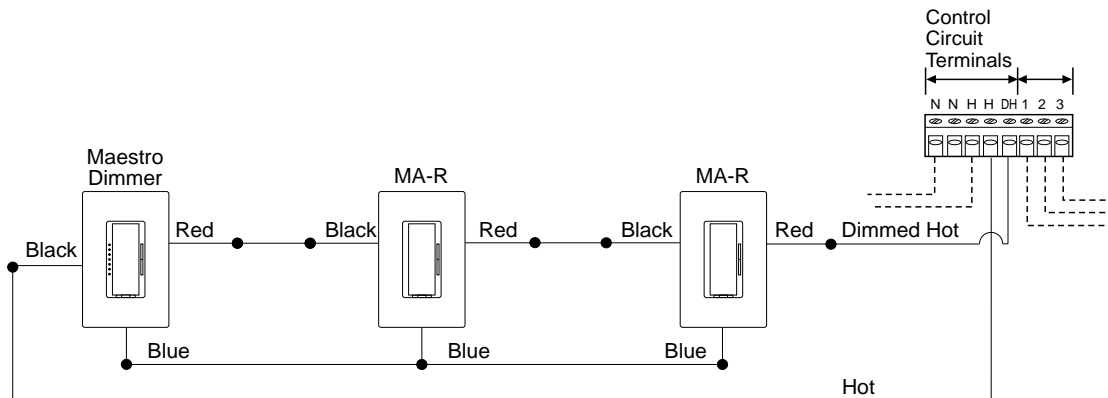

Diagram 7: Maestro Incandescent Dimmer (Three location)



Control Wiring

Diagram 8: Vareo Dimmer (Single location)

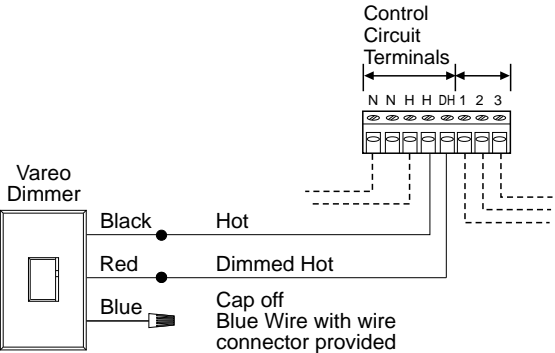

Diagram 9: Vareo Dimmer (Two location)

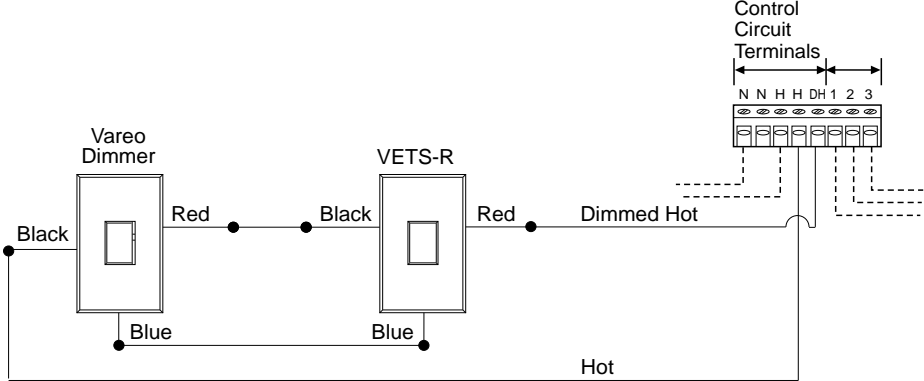
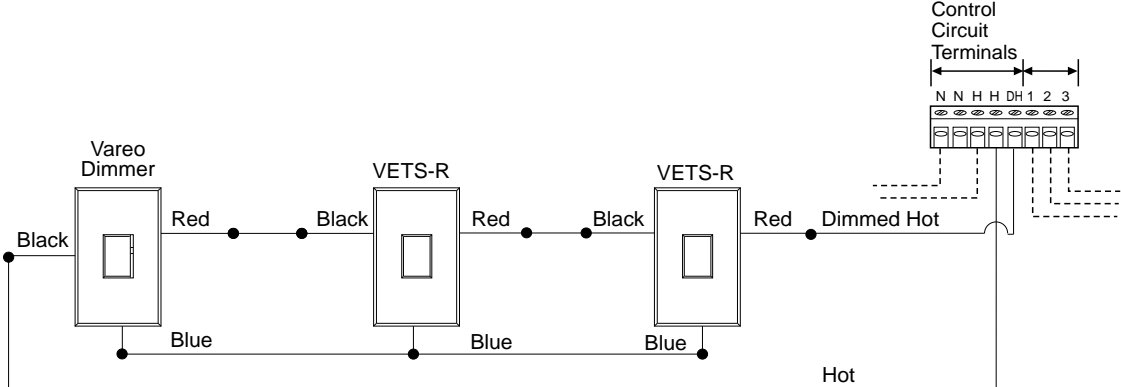

Diagram 10: Vareo Dimmer (Three location)



Control Wiring

Diagram 11: Nova T* Infrared Dimmer

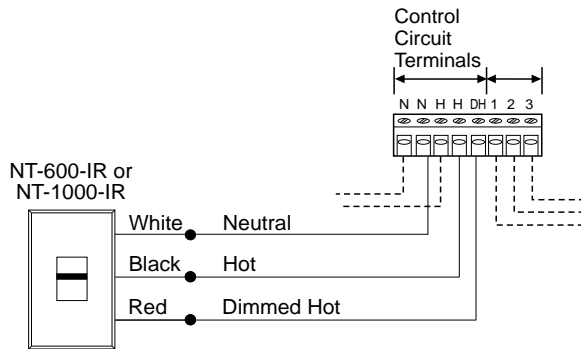

Diagram 12: Nova T* Omnislide Dimmers (Two location)

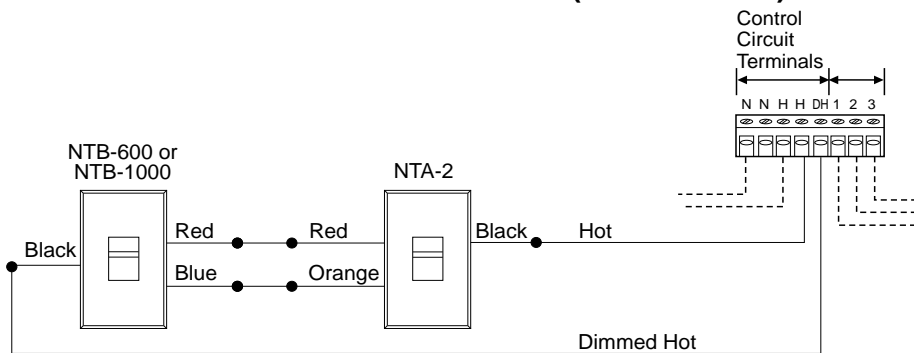
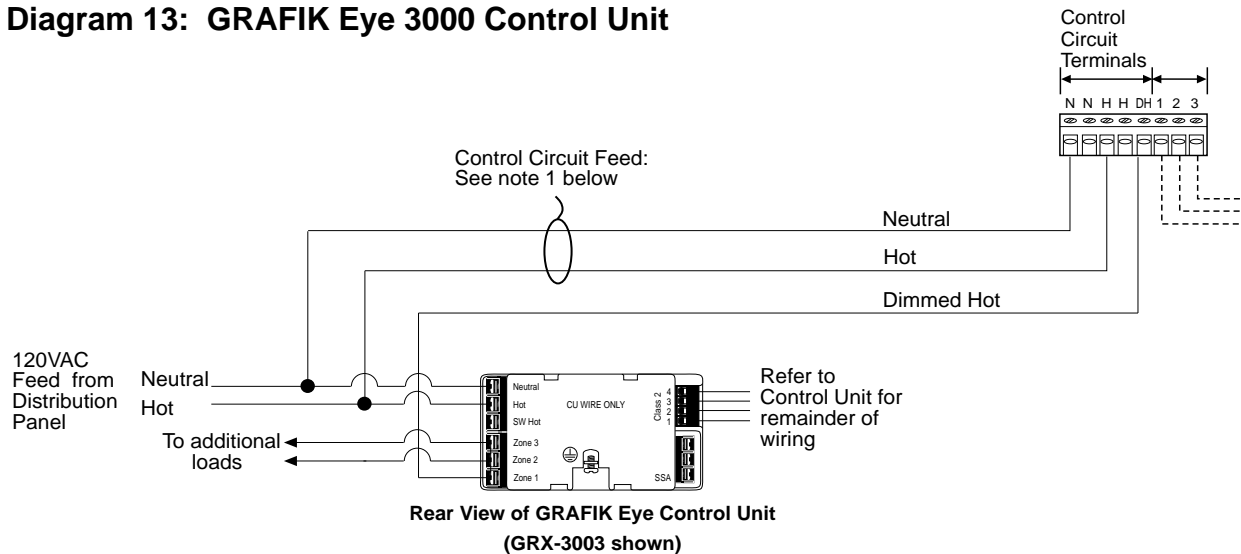

Diagram 13: GRAFIK Eye 3000 Control Unit



GRAFIK Eye 3000 Wiring Notes:

1. Control Circuit feed is shown coming from the GRAFIK Eye Control Unit's feed. The load for each Hi-POWER module connected to the circuit is 20VA. If the circuit does not have sufficient capacity to support the load of the module(s), the Control Circuit feed can be supplied from any circuit with sufficient capacity as long as it is on the **same phase** as the GRAFIK Eye Control Unit.
2. Load type should be set as incandescent on the GRAFIK Eye Control Unit.
3. Dimmed Hot is shown as Zone 1 in the diagram, but can be provided from any zone on the Control Unit.
4. Refer to GRAFIK Eye Installation Sheet for remainder of Control Unit wiring.

Class 2 Control Options

Definitions of Control Options

RAISE	Increases the light level while the switch is activated.
LOWER	Decreases light level while the switch is activated. Does not turn lights off.
LOWER/OFF	Decreases light level while the switch is activated. Turns lights off after the low-end is reached.
ON	Fades lights on to preset level.
OFF	Fades lights off.
TOGGLE	Fades lights on to preset level if they are off, fades lights off if they are on.
FULL ON	Turns lights on instantly to full when the switch is activated. No other control options are available while this switch is activated. Must be a maintained switch closure.
FADE RATE	Rate at which the light level changes while you activate a control option (for example, the rate at which the light level changes as you hold the RAISE button and the rate at which the lights fade on or off when you press the on or off). For all of the above options except "full on", the FADE RATE is adjustable inside the dimming module. See page 6 for location and adjustment instructions.

How to Access Control Options:

The desired Control Option is accessed with a 24VAC switch closure. Switch closures must be rated for switching 5mA at 24VAC RMS. See the chart below for the specific terminations of the switch closure on the Class 2 terminal block and type of switch closure permissible. See page 12 for the Class 2 terminal block location and terminal designations.

Typical Class 2 Control Wiring Examples:

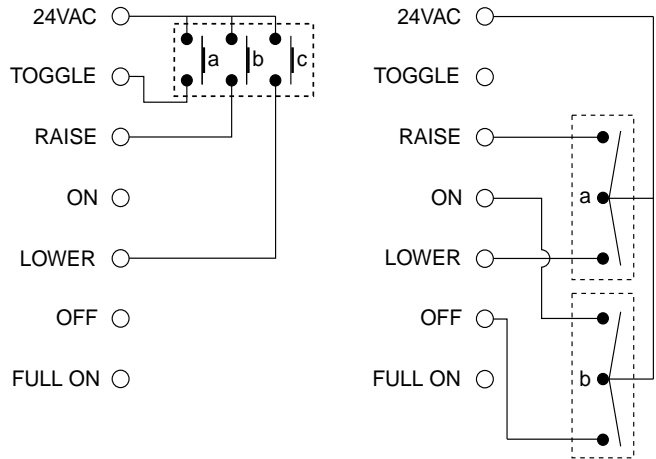

Example 1: Three SPST momentary pushbuttons. Switch "a" controls the TOGGLE on/off function. Switch "b" controls the RAISE function. Switch "c" controls the LOWER function.

Example 2: Two momentary, center off SPDT switches. Switch "a" performs the RAISE and LOWER functions. Switch "b" performs the ON/OFF functions.

Control Option	Switch Closure Between:	Switch Closure Type
RAISE	RAISE and 24VAC terminals	Either momentary or maintained
LOWER	LOWER and 24VAC terminals Remove factory installed jumper between LOWER & OFF terminals	Either momentary or maintained
LOWER/OFF	LOWER and 24VAC terminals DO NOT remove factory installed jumper between LOWER & OFF terminals	Either momentary or maintained
ON	24VAC and ON	Either momentary or maintained
OFF	24VAC and OFF	Either momentary or maintained
TOGGLE	24VAC and TOGGLE	Must be momentary
FULL ON	24VAC and FULL ON	Must be maintained

Neon/Cold-Cathode Dimming

Overview

Successful dimming of neon and cold-cathode sources can be achieved through proper equipment selection and installation. The following installation suggestions and Derated Luminous Tube Length Chart for Dimming Applications must be used for optimum performance.

1. If equipment is selected and installed as specified here, a dimming range of 95-10% light should be possible.
2. The electrical properties of argon fill gas make it easier to dim than red neon fill gas; therefore, installations using argon fill gas will be more successful than neon installations.
3. In addition to the following guidelines, all installations must meet the NEC and local codes.

Lamps

1. Neon/cold-cathode lamps must be manufactured to proper lamp pressurization (standard lamp pressure) without impurities. If pressurization is not standard or impurities are present, poor performance will result.
2. Neon/cold-cathode tubing should be well supported to avoid rattling when dimmed.
3. Lutron recommends using only the transformer/ tube combinations in the Derated Luminous Tube Length Chart for Dimming Applications. Other combinations will flicker and perform poorly. Note that there are few successful combinations for red neon tubes smaller than 11 mm.

Transformers

1. Normal power factor transformers must be used; electronic transformers cannot be dimmed.
2. When choosing transformer secondary currents, note that the higher the transformer current rating, the brighter the light from the tube.
3. Transformers must be sized according to the chart. These modified charts must be used by neon/cold-cathode transformer suppliers to size the transformer for dimming applications. Do not use standard luminous tube length charts to size transformers in dimming applications. Poor performance will result.
4. Transformers must be thermally-protected or fused.
5. Power factor correction capacitors, if present must be disconnected. If power correction is required, call the toll-free **Lutron Hotline** for details on power factor correction at the lighting controller.
6. Transformers should be sized to run as close as possible to full load footage as shown in the chart.

Wiring

1. High voltage (GTO-15) cable connecting a transformer output terminal to a cold-cathode tube must not be longer than twenty feet.
2. All GTO-15 cables should be spaced a minimum of four inches from any other GTO-15 cable.
3. It is recommended that only one GTO-15 cable be run per conduit.
4. Optimal dimming performance is achieved when GTO-15 cable is enclosed in plastic conduit or run without conduit. If codes require metal conduit, aluminum is preferred and lengths must be kept to less than six feet per transformer.
5. Braided or shielded GTO-15 cable must not be used for dimming applications.

Luminous Tube Length Chart for Neon/Cold-cathode Dimming Applications

Transformer Ratings			Approximate number of feet of tubing																					
Secondary Voltage (V)	Secondary Short Circuit Current (mA)	Input Volt-Amperes with Secondary Short Circuit (VA)	Neon Fill (clear or fluorescent red)										Argon /Mercury Fill (colors other than neon red)											
			Tube Size (millimeters)										Tube Size (millimeters)											
			25	22	20	18	15	14	13	12	11	10	9	25	22	20	18	15	14	13	12	11	10	9
15000	60	900	77	64	58	54	45	X	X	X	X	X	X	96	80	72	64	58	51	48	44	38	35	X
	30	450	77	64	58	54	45	X	X	X	X	X	X	96	80	72	64	58	51	48	44	38	35	X
	20	270					X	X	X	X	X	X					X	X	X	X	X	X	X	
12000	60	720	59	50	46	41	34	32	29	26	X	X	X	76	63	56	50	44	40	37	35	30	28	X
	30	360	59	50	46	41	34	32	29	26	X	X	X	76	63	56	50	44	40	37	35	30	28	X
	20	225					X	X	X	X	X	X					X	X	X	X	X	X	X	
9000	120	1080	58	49	41	35	28	25	25	23	20	17	X	74	62	50	42	37	33	30	28	26	22	X
	60	540	50	43	36	30	25	23	22	20	18	16	X	64	54	44	36	32	29	26	26	22	20	X
	30	270	50	43	36	30	25	23	22	20	X	X	X	64	54	44	36	32	29	26	26	22	20	X
7500	20	180					21	20	18	16	X	X	X					27	25	23	22	18	16	X
	120	900	44	35	29	24	22	20	20	17	16	14	X	56	44	36	31	28	26	25	22	20	18	X
	60	450	38	31	25	21	20	18	16	16	14	13	X	49	38	31	28	25	22	22	20	18	16	X
6000	30	225	38	31	25	21	20	18	16	16	X	X	X	49	38	31	28	25	22	22	20	18	16	X
	20	150					16	16	15	14	X	X	X					22	20	18	17	15	14	X
	120	720	35	29	24	20	18	16	16	14	13	11	X	44	37	30	26	22	21	20	18	16	14	X
5000	60	360	30	25	21	17	16	14	14	12	11	10	X	38	32	26	22	19	18	17	15	14	13	X
	30	180	30	25	21	17	16	14	14	12	X	X	X	38	32	26	22	19	18	17	15	14	13	X
	20	130					14	13	12	10	X	X	X					18	16	14	14	12	10	X
4000	120	600	28	24	20	16	15	14	13	10	9	8	X	37	30	25	21	18	18	15	14	12	10	X
	60	300	25	21	17	14	13	12	11	9	8	8	X	32	26	22	18	16	15	13	13	10	10	X
	30	160	25	21	17	14	13	12	11	9	X	X	X	32	26	22	18	16	15	13	13	10	10	X
3000	20	100					11	10	10	8	X	X	X					14	13	12	11	9	8	X
	60	240	20	17	14	12	10	9	8	8	7	6	X	26	22	18	15	14	13	12	11	9	8	X
	30	140	20	17	14	12	10	9	8	8	X	X	X	26	22	18	15	14	13	12	11	9	8	X
2000	20	90					8	8	8	7	X	X	X					11	10	10	10	7	6	X
	60	180	13	10	9	8	8	7	7	6	5	5	X	18	14	13	11	10	9	8	7	6	6	X
	30	100	13	10	9	8	8	7	7	6	5	5	X	18	14	13	11	10	9	8	7	6	6	X
2000	20	75					6	6	5	5	4	3	X					8	7	6	6	5	4	X
	30	75					5	5	5	5	X	X	X					7	6	6	6	5	4	X
	20	50					5	4	4	4	X	X	X					6	6	6	5	4	3	X
Recommended gas pressure, mm/Hg			6	7	7.5	8	9	10	10	11	12	13	6	7	7.5	8	9	10	10	11	12	13		

NOTES:

- This table has been modified for dimming applications. When calculating total length of tube, add approximately 1 foot for each section of tubing (each pair of electrodes).
- **Do not** use this table for non-dimming installations.
- X denotes a combination which cannot be successfully dimmed.
- Tube length is shown in feet. To convert to meters: 1 foot = 0.305 meters.



WARNING: Potentially hazardous high voltage can be present. Testing, handling, and servicing should be performed only by a qualified electrician.

Troubleshooting Guide

Symptom	Causes	Solution
Lights do not come on.	Load input feed power not present	Check load power indicator light(s) and verify that all input breakers are on and wiring is connected properly.
	Control input feed power is not present.	Check control power indicator light and verify that the control wiring is connected properly.
Lights cannot be dimmed.	Bypass jumpers are not removed.	Remove bypass jumpers on load circuit terminal blocks.
	Dimmed load is miswired to switched hot output load terminal.	Compare load wiring to wiring diagrams on page 7.
	Low-end trim is set too high.	Refer to page 6 and adjust low-end trim.
	Control dimmer is not operating properly.	Check that Control Power Indicator Light dims when control is adjusted; check wiring.
	Shorted triac - usually caused by a load short or overload.	Try to adjust high-end or low-end trim. If lights remain at full, triac is shorted. Contact Lutron for a Replacement Triac Kit . Verify proper load size and load wiring before replacing triac.
Portion of slider travel does not affect light level.	High- and/or low-end trim need adjustment.	Refer to page 6 and adjust high- and/or low-end trim settings.
Hi-lume FDB or Eco-10 lamps flicker at low-end.	Lamps not operated at full intensity before dimming.	Operate lamps at full intensity for 100 hours prior to dimming.
	Hi-lume FDB or ECO 10 ballasts improperly wired to Dimming Module.	Refer to wiring diagram on page 7 and correct wiring.
Neon lamps flicker at low-end.	Low-end trim is set too low.	Refer to page 6 and adjust low-end trim.
	There is a problem with the neon installation.	Refer to pages 14 and 15 for approved neon dimming installation specifications.
Switched load does not turn off.	Bypass jumper not removed.	Remove bypass jumpers on load circuit terminal blocks.
Lights do not dim low enough.	Low-end trim needs adjustment.	Refer to page 6 and adjust low-end trim.
Lights do not brighten to full or remain at low-end.	High-end trim is set too low.	Refer to page 6 and adjust high-end trim.
Lights on different dimming modules dim at different rates when using Class 2 raise/ lower controls.	Fade rate adjustment set differently on each module.	Refer to page 6 and adjust fade rates so that they are the same.
Circuit breaker trips on power up.	Additional dimming module slaves wired incorrectly.	Compare additional module wiring to diagrams on page 4.

Worldwide Technical and Sales Assistance

If you need assistance, call the toll-free **Lutron Technical Assistance Hotline:**
 (800) 523-9466 (U.S.A., Canada and the Caribbean)
 Other countries call (610) 282-3800
 FAX (610) 282-3090

Warranty

Lutron will, at its option, repair or replace any control that is defective in materials or manufacture within one year after the purchase. For warranty service, return control to place of purchase or mail to Lutron at 7200 Suter Road, Coopersburg, PA 18036-1299, postage prepaid.
 This warranty is in lieu of all other warranties, express or implied, and the implied warranty of merchantability is limited to one year from purchase. This warranty does not cover the cost of installation, removal, or reinstallation, or damage resulting from misuse, abuse, or improper wiring or installation.
 This warranty gives you specific legal rights, and you may also have other rights which vary from state to state. Some states do not allow the exclusion or limitation of incidental or consequential damages or limitations on how long an implied warranty may last, so the above limitations and exclusions may not apply to you.

LUTRON®

Lutron Electronics Co., Inc.
 7200 Suter Road
 Coopersburg, PA 18036-1299 USA
 Made and Printed in U.S.A. 6/96 P/N 030-452 Rev. B