

LCP128™

Dimming and Switching System



Table of Contents

Introduction and System Startup

	<u>Page</u>
How to Use this Guide	4
System Specifications	5
System Start-Up Checklist.....	7
Controller Overview	9







Step-by-Step Programming Instructions

	<u>Page</u>
Overview	14
STEP 1: Panel Configuration	15
STEP 2: Time Clock Configuration.....	22
STEP 3: Scene Modification	27
STEP 4: Control Stations	29
STEP 5: Time Clock Events	44
STEP 6: Panel Contact Closure Inputs	50
STEP 7: Emergency Power Mode	54



Reference Information

	<u>Page</u>
 Referenced Functions	
Overrides	57
Locking and Unlocking the Controller	61
 Troubleshooting Guide	
Troubleshooting Guide	63
 Maintenance	
Maintenance	68
 Glossary of Terms	
Glossary of Terms	69
 Tables	
Panel Tables	70
Module Type Table	74
Load Type Table	75
Control Location Table	76
Control Station Table	77
Time Clock Event Table	79
Warranty	80
Contact Information	80

Introduction

How to Use this Guide

This programming guide contains three main sections:

- **Introduction** - Includes system specifications, electrical contractor Start-Up Checklist, and an overview of the controller and how to use it.
- **Step by Step Programming Instructions** - Walks you through each step needed to program your system.
- **Reference Information** - Includes additional procedures that you may need to perform after the system is programmed, including how to override system settings and lock/unlock the controller. This section also includes troubleshooting tips, system maintenance, a glossary of terms, and system planning tables.

When programming the *LCP128* system, you will need to know the following key information:

- How many panels are in this system and how many circuits are in each panel.
- How many modules are in the system and the module types.
- What the load schedule is.
- Where each wallstation and key switch is located and what each button or key turn should do.
- What each contact closure input and output should do.
- What the time clock should do.

Please read the guide completely before attempting to program the system.

Tables are provided at the back of this guide to record the above information. Photocopy the tables as needed, and leave them for the occupant after they are completed.

Note: For mounting and wiring information, refer to the appropriate panel installation guide.

System Overview Diagram

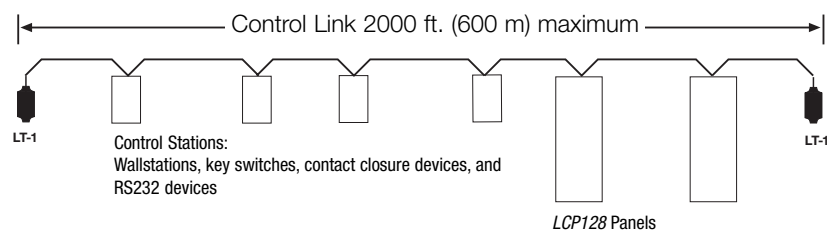

Introduction

System Specifications

LCP128 is a lighting control system designed for commercial buildings. It consists of up to 8 dimming panels and up to 32 control stations. Control stations can be wallstations, key switches, contact closure input and output devices (OMX-AV), contact closure output devices (OMX-CCO-8), theatrical (ODMX-512) control interfaces, or building management system interfaces (OMX-RS232). All panels and control stations are connected by a digital communications link. Refer to the appropriate panel installation guide for wiring details. Other system specifications are described below.

Time Clock

- 7 weekly schedules.
- Up to 40 holiday schedules.
- Each holiday schedule can be 1-90 days.
- Up to 500 time clock events.
- Maximum of 25 time clock events per day.
- Up to 32 scenes and 1 Off scene.
- With each time clock event or control station input, you can select which circuits turn on or off and, for dimming circuits, set specific dimming levels.
- Time clock events can occur at a fixed time of day or at a time relative to sunrise or sunset (astronomical).
- Events can be placed on either a weekly schedule (for example, occurring every Monday) or a holiday schedule (for example, occurring only on January 1).
- Holiday schedules override weekly schedules.
- Time clock events can start and end afterhours mode. Afterhours is an energy saving mode where lights that are set to be off will automatically, after a period of time, turn themselves off. Afterhours mode can be temporarily overridden by any control station action. See STEP 5 for more information.
- Time clock events can enable and disable control stations.

Control Station - Wallstation

Wallstation buttons can be individually programmed to:

- Select a scene or custom scene. A scene is a combination of preset lighting levels used to automatically turn on, off, or dim a circuit or group of circuits. Each time the wallstation button is pressed, the circuits go to the programmed scene settings.
- Raise or lower circuits. Dimming circuits progressively raise or lower as long as the button is pressed. Circuits stay at this setting until another event or control station input occurs.
- Toggle circuits on and off. Each press of the button alternates between turning the circuits on and off. If the circuits are in a mixed state (some on and some off), the lights turn on.
- Turn off with a time delay. When the button is pressed, the circuits turn off after a preset amount of time.
- Enable or disable time clock.

Control Station - Key Switch

- The key switch (NTOMX-KS) can be programmed for clockwise and counterclockwise turns and with the same functions as a wallstation button.

Introduction

Control Station - Contact Closure Inputs

Two contact closure inputs are available on each *LCP128* controller – more are available by purchasing a Lutron OMX-AV control station (five inputs per OMX-AV that can be added anywhere on the digital control station link). Also, an OMX-WCI can provide up to seven control inputs to the lighting control system.

- The contact closure inputs can be programmed on the open and/or closure of the contact to perform the same functions as a wallstation button.
- SeeTouch™ wallstations have two contact closure inputs (optional version of one input and one 24 V $\overline{\text{---}}$ power for an occupant sensor).

Control Station - Contact Closure Outputs

Contact closure outputs can be added with either a Lutron OMX-AV control station (five outputs per OMX-AV) or with a Lutron OMX-CCO-8 (eight outputs per OMX-CCO-8). Either control station can be added anywhere on the digital control station link.

- Each contact closure may be momentary or maintained.
- Each contact closure output can be assigned to an action that is programmed to a wallstation button, key turn, contact closure input, time clock event, or emergency state.

Integration through RS232

The *LCP128* system can be integrated with a building management system through the Lutron RS232 interface (OMX-RS232, OMX-CI-NWK-E, or OMX-CI-RS232).

DMX Theatrical Integration

The *LCP128* system can take up to 32 DMX inputs from a theatrical lighting console/stageboard through the Lutron ODMX-512 interface.

Emergency Power Mode

When a *LCP128* panel is placed into emergency power mode (loss of normal power), circuits are changed to emergency settings and remain at those settings until the controller exits emergency power mode (return of normal power). All control station inputs and time clock events are ignored while in emergency power mode.

Emergency power mode can be activated using:

- Panel to panel emergency sense line. This method requires that the system have at least two panels. The system must have at least one normal (non-essential) feed panel and at least one emergency (essential) feed panel. When power to the normal panel is interrupted, the emergency panel(s) will go into emergency mode. Note that the normal / emergency switches at the bottom of the controllers need to be set correctly.
- The Lutron emergency lighting interface (LUT-ELI-3PH), a UL 924 listed device, senses the normal (non-essential) line voltage on all three phases (3PH) of normal power. When one or more phases of power are lost, the LUT-ELI-3PH sends a signal to the *LCP128* controller. If the *LCP128* controller's normal / emergency switch is set to emergency, the emergency lighting scene or programmed circuit levels are activated.

For more information on emergency lighting applications, refer to Application Note #106, available at www.lutron.com.

System Start-Up Checklist

LCP128™ System Start-Up Checklist for Electrical Contractor

Important Note:

To ensure that the LCP128 System is ready for Start-Up, please complete the following checklist.

- The LCP128 panel(s) and control station(s) have been mounted in accordance with the installation instructions.
- Control stations have been wired to the panel in accordance with installation instructions.
- Feed and load wiring to panel have been installed in accordance with the installation instructions.
- All load circuits have been activated in bypass mode (bypass jumpers installed) and are correctly and permanently lamped.
- Bypass jumpers have been removed and all circuits activated as default Non-Dim load type.
- Load schedule for each panel has been completed.
- Correct load type for each circuit has been determined and recorded.

When the above checklist is completed, please fax this sheet along with the completed load schedule for each panel to Lutron Field Service Scheduling at (610) 282-0298.

Signature: _____

Job Name: _____

Today's Date: _____

Lutron Job Number: _____

Printed Name: _____

Scheduled Startup Date: _____

Phone Number: _____

Scheduled Startup Time: _____

Fax Number: _____

Job Site Number: _____

Bill of Material (panels, control stations, etc.):

_____	Qty. _____
_____	Qty. _____
_____	Qty. _____

Lutron Electronics Co., Inc.

7200 Suter Road

Coopersburg, PA 18036-1299

Telephone:

In the U.S., Canada, and the Caribbean: 1.800.523.9466

In Mexico: 888.235.2910

In Europe: +44.207.702.0657

In Asia: +65.6220.4666

In Japan: +81.355.758.411

In all other countries: +1.610.282.6701

(Listen to menu for scheduling)

PELV (Class 2: USA) Wiring

Panel to Panel and Panel to Control Stations

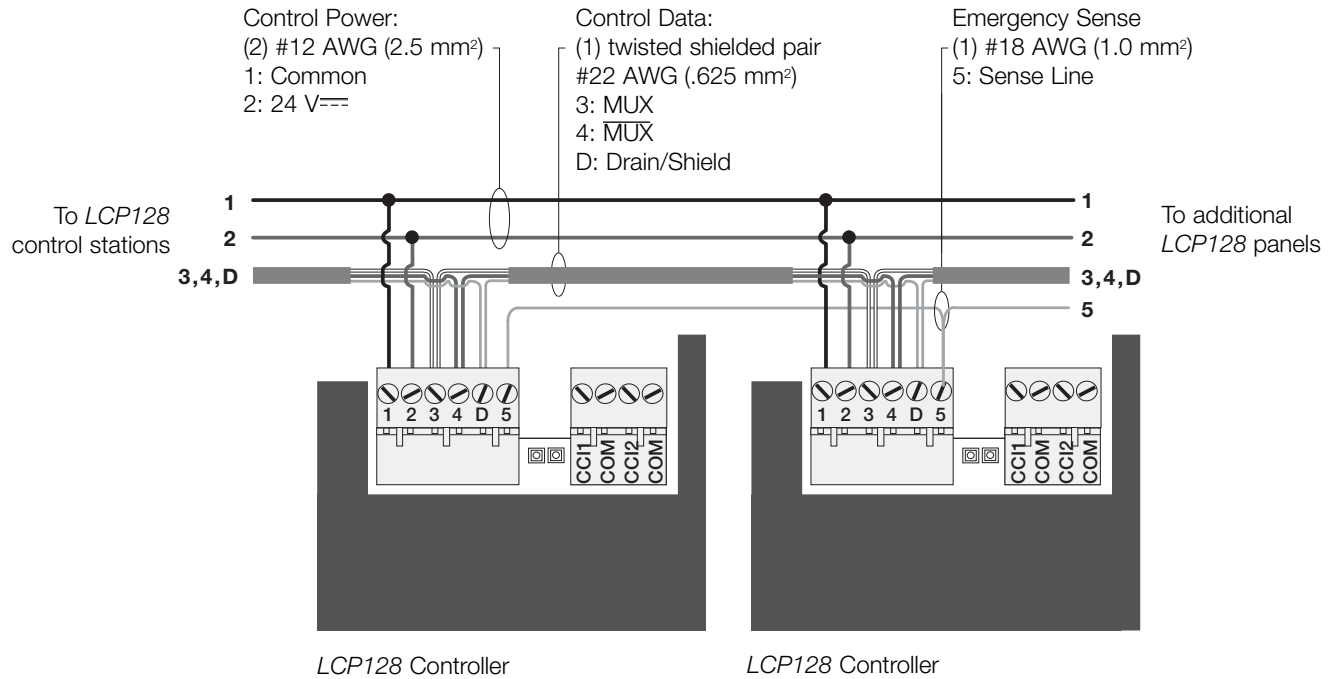

Notes

- Use a wire connector to attach one #18 AWG (1.0 mm²) wire for Common (terminal 1) and one #18 AWG (1.0 mm²) wire for 24 V_{AC} (terminal 2) from the PELV (Class 2: USA) link to the control. Two #12 AWG (4.0 mm²) wires cannot both be terminated on the control station. Maximum wire length from link to control is 8 ft. (2.4 m).
- Only connect the Drain/Shield wire (bare copper) to terminal 'D' in LCP128 panels. Maintain the shield throughout the link but do not allow it to touch ground (earth) or wallstation circuitry.

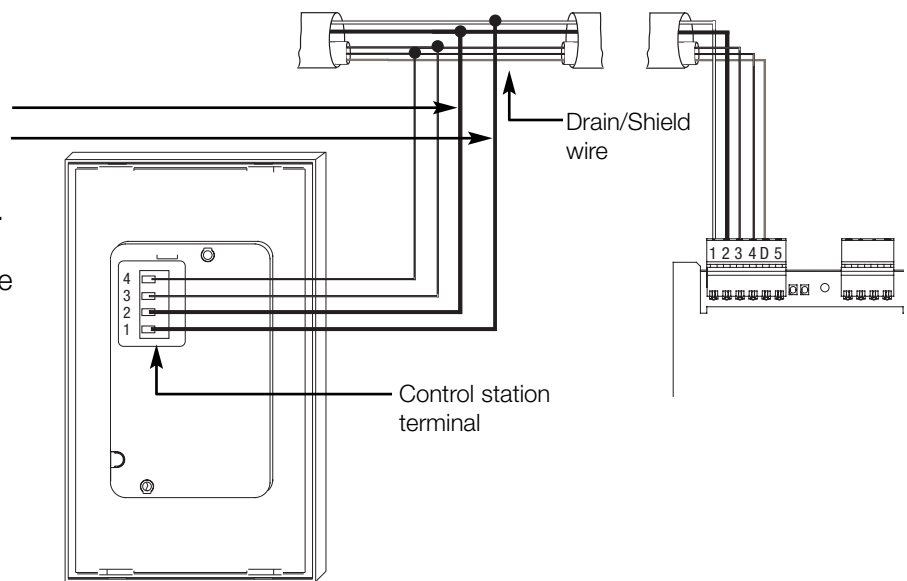

Controller Overview

LCP128™ Controller Layout

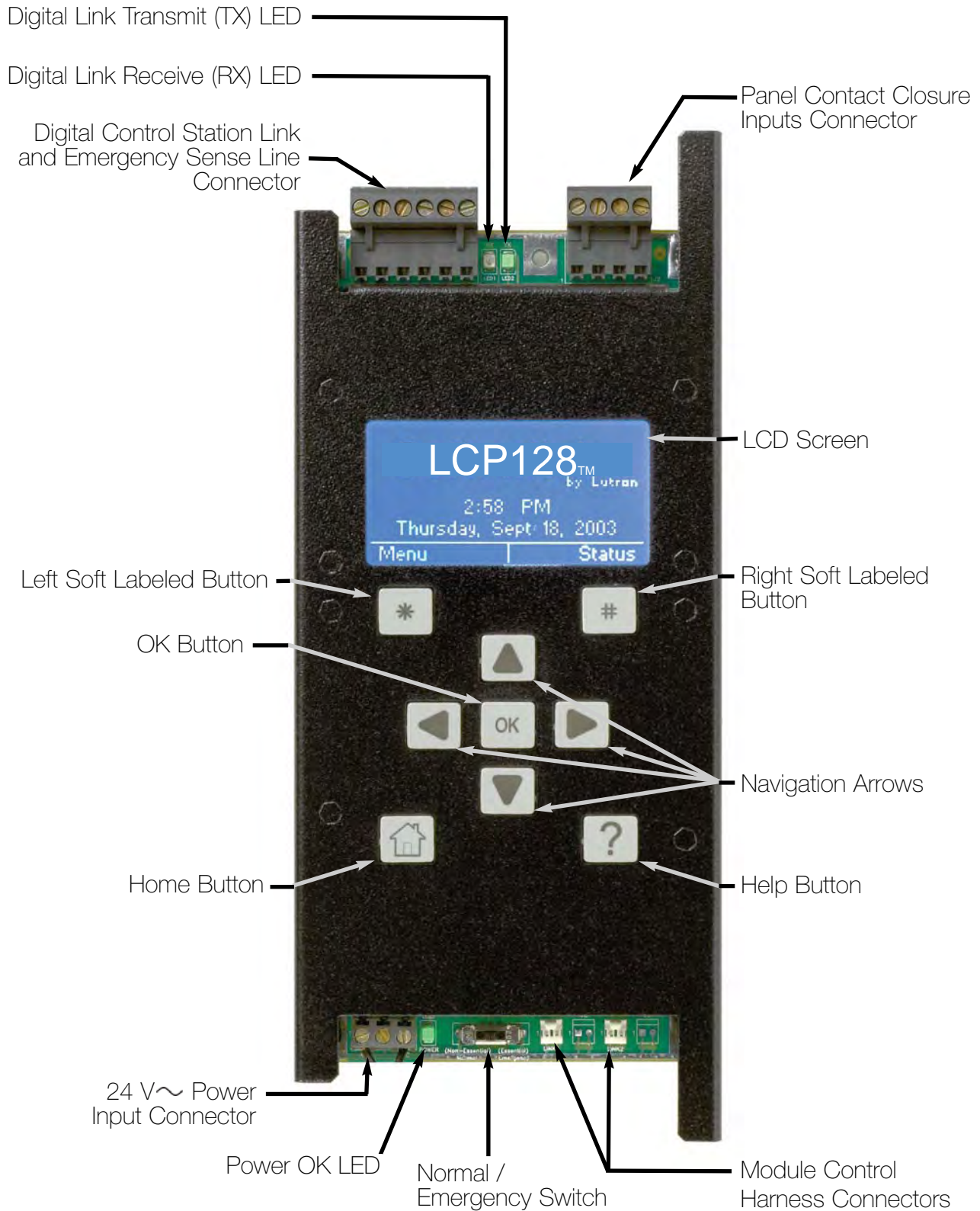

Controller Overview (continued)

Navigation

The *LCP128* controller uses certain methods for navigating, selecting, setting values, etc. Please read this section carefully before using the controller to program your system.

The *LCP128* controller has nine buttons below the display. The table below explains their functions.

Button	Function
	Navigate the screen and change highlighted values
	Select an item
	Left Soft-Labeled – Function defined on screen
	Right Soft-Labeled – Function defined on screen
	Go to the Home screen
	On-Screen Help

The Screen

All screens on the *LCP128* controller have a similar look with some common elements. These are:

- A screen title
- Left and right soft button labels
- A scroll bar (only present if more information is available than will fit on the screen.)

The example shows the Main Menu. The scroll bar indicates that there is more information in the menu than fits on the screen. Pressing repeatedly (or press and hold) scrolls through the menu and shows other choices. The shaded slider on the scroll bar indicates what portion of the menu is being displayed.

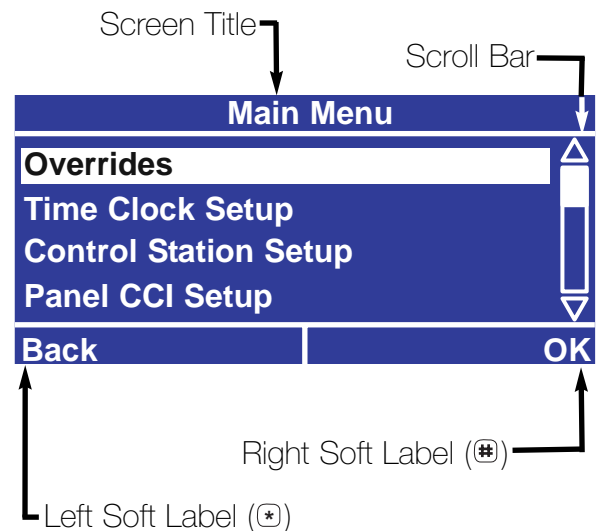

Help

Help on the current screen is always available by pressing the button. If more information is available than fits on the screen, use and to scroll through the text. Pressing either , or returns you to the screen you were on.

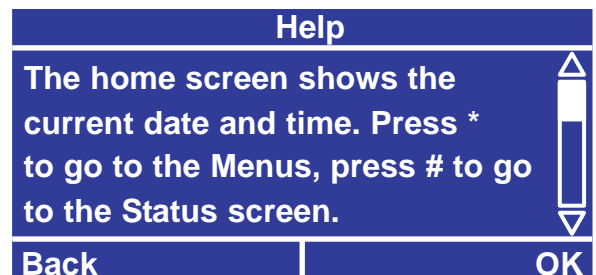

Controller Overview (continued)

Getting to the Home Screen





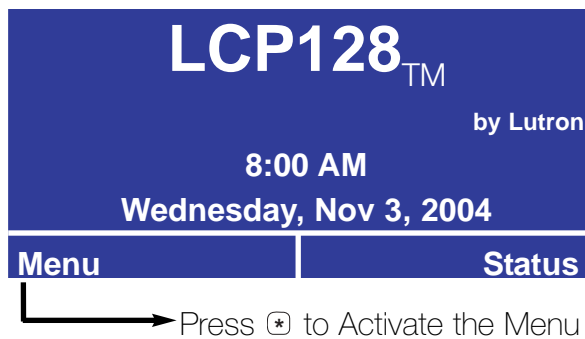

Press  from any screen to go back to the Home screen.

Accessing the Main Menu

From the Home screen, press  to go to the Main Menu. If a password has been set, you need to enter it before continuing (see “Locking and Unlocking the Controller” in the reference section later in this guide).



Navigating the Menus

When in a menu, use  and  to change the highlighted item and press  or  (OK) to select that item. Pressing  provides help on that item. To go back to the previous screen, press  (Back).

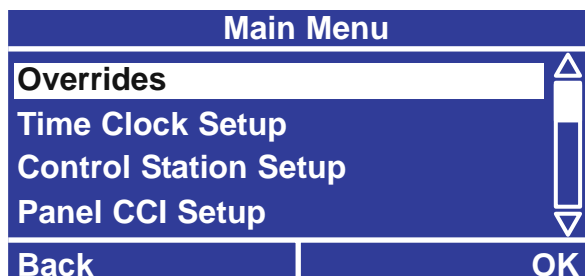

Entering Data

One or more screens are used to program the information required for each system feature.

If only one screen is required, the screen has the soft labeled buttons “Cancel” and “Done”.

If multiple screens are required, the first screen has the soft labeled buttons “Cancel” and “Next”. Intermediate screens have the soft labeled buttons “Previous” and “Next”, and the last screen has the soft Labeled buttons “Previous” and “Done”.

Note: Data is not stored in the LCP128 system database until “Done” is selected.

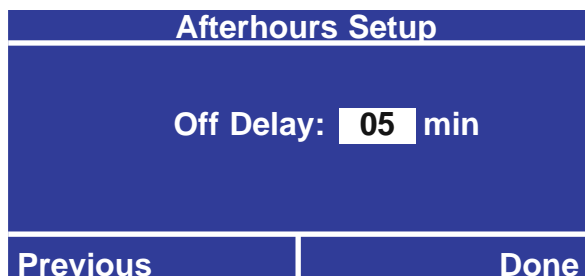
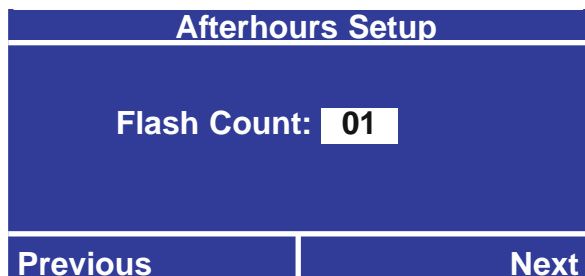
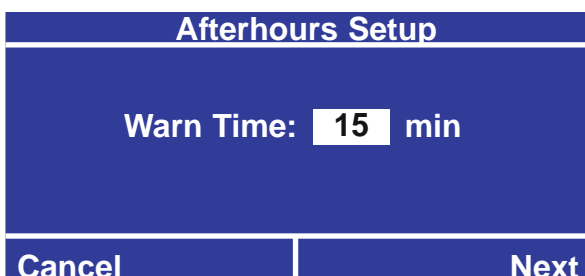

Controller Overview (continued)

Language Select Screen

When the controller is first powered, you are prompted to choose a language for the screens. Use the navigation arrows to select a language, then press **OK** or **Done**.



Getting Started - The Home Screen

- When the controller is first powered or is not used for 20 minutes, the display shows the Home screen. Pressing **Home** (the Home button) always takes you back to this screen. From the Home screen, pressing **Menu** displays the Main Menu and pressing **Status** displays the Panel Status screen.
- The Home screen shows the current day, date and time set on the controller. If either of these are incorrect, refer to STEP 2 to set the date, time, and location.
- The backlight on the LCD turns off after 25 minutes of no activity. Pressing any button on the control turns the backlight on and displays the Home screen.

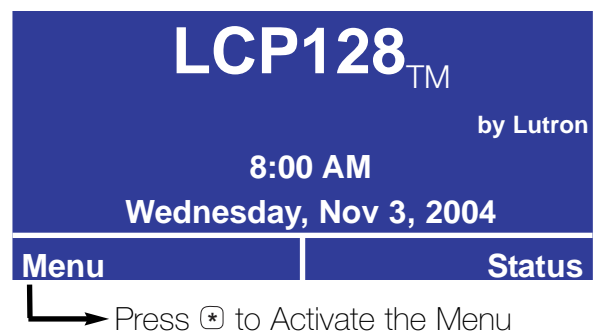

Unlocking the Controller

If the controller has been locked (see “Locking the Controller” in the referenced function section) you are prompted to enter the password before the Main Menu is activated. Press **Left** and **Right** to select the digit to change. Then press **Up** and **Down** to change each digit. When you have entered the password, press **OK**.

If you forget the password, contact Lutron technical support at (800) 523-9466 to unlock the controller.

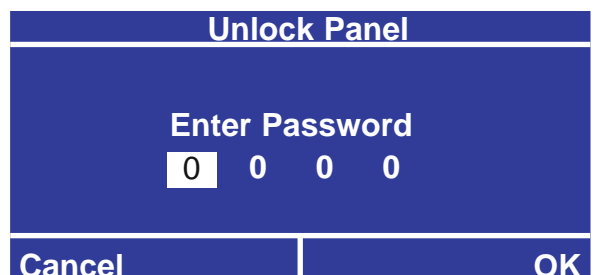

Controller Overview (continued)

The Panel Status Screen

Pressing **Ⓜ** from the Home screen displays the Panel Status screen. The Panel Status screen shows:

- Your location.
- Time clock status (Enabled/Disabled).
- Control station status (Enabled/Disabled).
- Today's sunrise time for the current system date (note that the time, date, and location must be configured correctly).
- Today's sunset time for the current system date (note that the time, date, and location must be configured correctly).
- Memory used.
- Build version.

Panel Status	
Philadelphia, Pennsylvania	
Today's Sunrise: 05:59AM	
Today's Sunset: 6:07PM	
Time Clock : Enabled	
Back	Link Detail

The Wallstation Status Screen

Pressing **Ⓜ** from the Panel Status screen displays the Wallstation Status screen. The Wallstation Status screen shows:

- If the station is present and is recognized, the control is labeled by its type (for example, "seeTouch").
- If a station is not present, it is labeled as "No Station". This could also indicate a control station address conflict.
- If the unit is present and is not a control that is known to the system, the control is labeled as "???". This could also indicate a control station address conflict.

Wall Station Status	
P08	- Panel 8
A01	- No Station
A02	- seeTouch
A03	- Address 3
Back	Levels

The Circuit Levels Screen

Pressing **Ⓜ** from the Wallstation Status screen displays the Circuit Levels screen. The Circuit Levels screen shows the current circuit levels on the system.

Circuit Levels		
All Circuits	- - -	
001	Dim	- FLASH
002	Dim	- 100%
003	Relay	- O N
Back	OK	



Step by Step Programming Instructions

Overview

Programming your *LCP128* system is done in seven steps.

1. Panel Configuration

This step selects a language for the controller LCD and configures the load setup. For multiple panel systems, this step also assigns panel addresses and configures the number of circuits in each panel.

2. Time, Date, and Location

Required if the time clock will be used. This step shows how to set the clock.

3. Scene Modification

Required if changes to the default scene settings are needed.

4. Control Stations

Required if there is a remote wallstation, key switch, contact closure device, and/or RS232 device. This step is performed to configure their function.

5. Time Clock Events

Required if the time clock will be used. This step is used to automatically dim or turn circuits on/off at either a specific time of day or at a time relative to sunrise or sunset.

6. Panel Contact Closure Inputs

Required if the panel contact closure inputs are used. This step defines what each input will do.

7. Emergency Power Mode

Required if emergency lighting is needed when normal power is lost. Control station inputs and time clock events are ignored while in emergency power mode. This step defines if the panel has emergency circuits and how to configure the emergency lighting.

The following pages explain how to perform each of the programming steps.



STEP 1

Panel Configuration

To program a *LCP128* panel, you need to:

- **Choose a language** for the controller LCD.
- **Set the panel configuration**, including:
 - Panel address
 - First circuit number in the panel
 - Number of circuits in the panel

Each circuit in the system is identified by a system circuit number. This number will be used to identify the circuit for programming purposes. For example, if Panel 1 has 12 circuits, the first circuit in Panel 2 will be circuit 13 on the *LCP128* controller. The figure below shows a sample system.

Note: *If your system has only one panel, you do not need to set the panel configuration. The panel address, first system circuit number, and number of circuits are preprogrammed. However, for multi-panel systems, you must set the panel configuration from the master panel (address 1) and then from each remote panel.*

- **Configure the load setup**, including:
 - Module type setup
 - System size
 - Load type
 - High end trim
 - Low end trim

All system programming (covered in programming STEPS 2-7) is performed at **panel address 1**. In a multi-panel system, panel address 1 becomes the master programming panel and all other panels are remote panels. Remote panels have limited menu options and functionality.

Before proceeding with STEP 1, complete the Panel, Module Type, Load Type, and Control Station Tables located at the back of this guide.

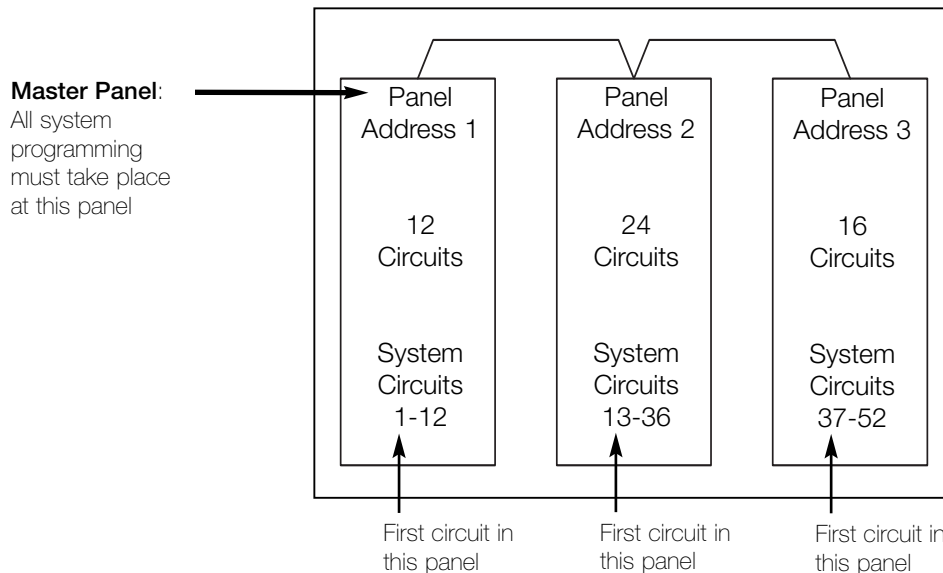



STEP 1 (continued)

Choose a Language

- From the **Main Menu** use and to highlight **Panel Setup** and press or (OK).
- Use and to highlight **Choose Language** and press or (OK).
- Use and to set the **Language** and press or (Done). The default is English.

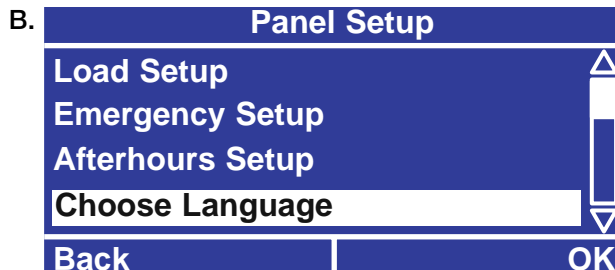
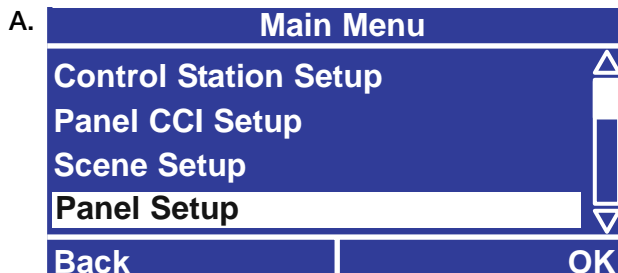

Set System Size

You can set the system size so that controller screens display only the circuits used by your system. The default system size is 128 circuits.

- From the **Main Menu** use and to highlight **Panel Setup** and press or (OK).
- Use and to highlight **Load Setup** and press or (OK).
- Use and to highlight **System Size** and press or (OK).
- Use and to set the total number of system circuits and press or (Done).

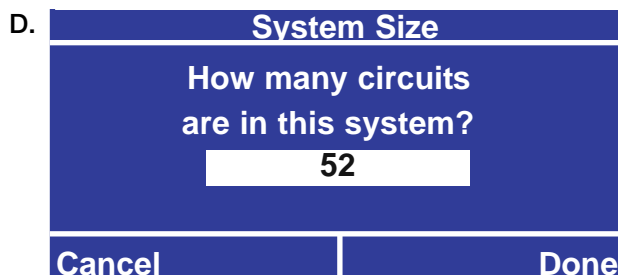
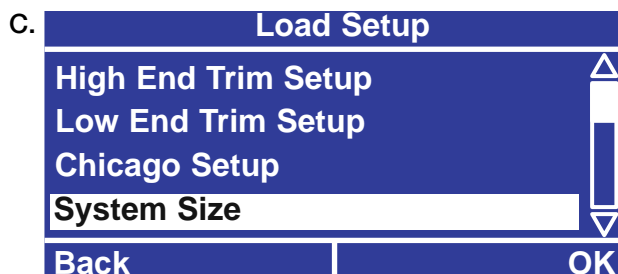



STEP 1 (continued)

Set Panel Configuration - Multi-Panel Systems Only

For multi-panel systems, you must set the address and number of circuits for each panel, beginning with the master panel.

- A. From the **Main Menu** at the master panel controller, use and to highlight **Panel Setup** and press or (OK).
- B. Use and to highlight **Panel Addressing** and press or (OK).
- C. Use and to set the **Panel Address** and press or (Next).
Master panel address = 01
- D. Use and to set the first system circuit number in the panel, and press or (Next).
- E. Use and to set the number of circuits in the panel and press or (Done) to update the database.
- F. Repeat this procedure at each remote panel to set the panel address and number of circuits.
Panel 2 address = 02
Panel 3 address = 03
Etc.

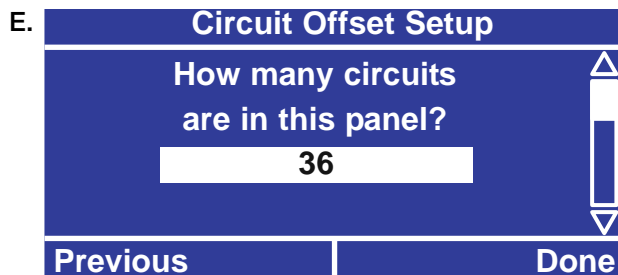
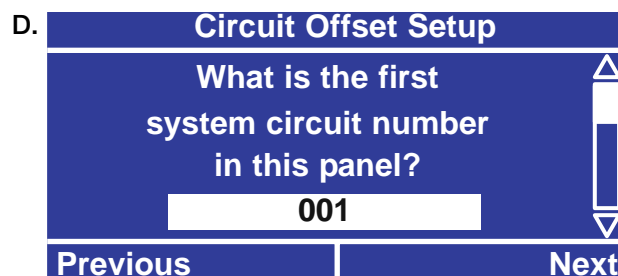
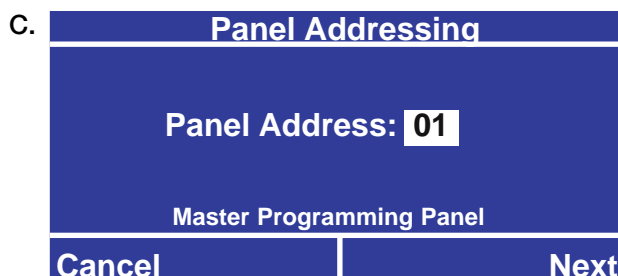
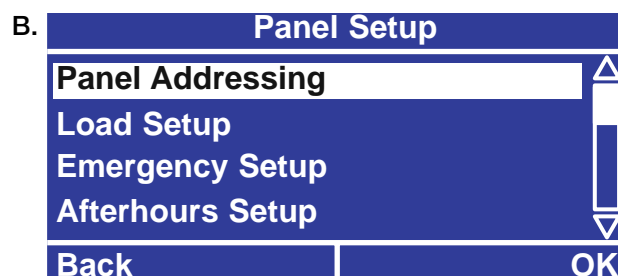
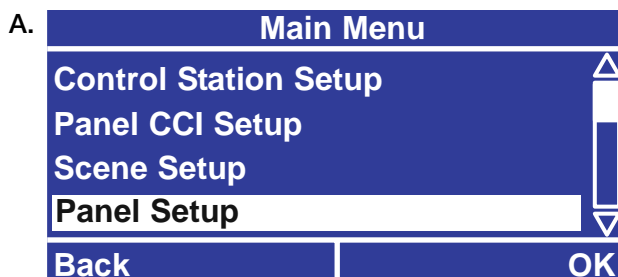



STEP 1 (continued)

Module Type Setup

Your LCP128 system contains modules configured with one or more outputs (circuits). The module types are set by the model numbers of the panels in the system. Complete the Module Type Table at the back of this guide and then program the module types for your system. The factory default module type is X (4 Switches).

- A. From the **Main Menu** use and to highlight **Panel Setup** and press or (OK).
- B. Use and to highlight **Load Setup** and press or (OK).
- C. Use and to highlight **Module Type Setup** and press or (OK).
- D. The Module Type Setup screen lists all the circuits. To program a module, use and to select the first circuit number in the module and and to set the module type.

Module type options include:

- X:** Four-Circuit Switching (Relay) Module (XP)
- S:** One-output (circuit) Dimming Module (1U)
- D:** Two-output (circuit) Dimming Module (2U)
- Q:** Four-output (circuit) Dimming Module (4U)
- E:** Four-output (circuit) Electronic Low Voltage Dimming Module (4E)
- A:** Four-output (circuit) Adaptive Dimming Module (4A)
- M:** Four-output (circuit) Motor Module (4M)
- F:** Four-output (circuit) Quiet Fan Speed Module (4FSQ)
- G:** GP panel dimmer card (G4) - assigned in groups of four

Notes:

As you set each module type, the appropriate circuit numbers are automatically assigned to the module.

If you set the system size earlier in STEP 1, the Module Type Setup screen lists only the circuits used in your system.

- E. When all the module types are set press or (Done).

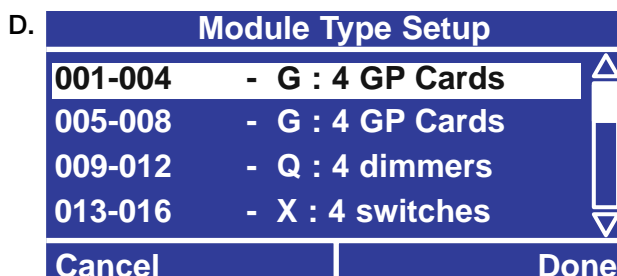
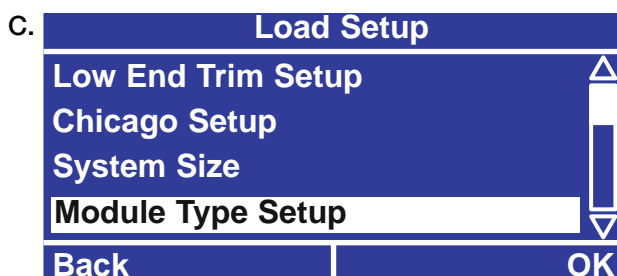
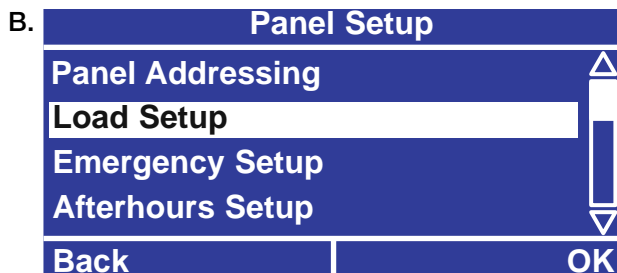



STEP 1 (continued)

Load Type Setup

Complete the Load Type Table at the back of this guide and then program the load types for your system circuits. The factory default load type for each circuit is Non-Dim.

Note: If you are unsure of the load type for a particular circuit, set the load type to Non-Dim until the correct setting is determined.

- A. From the **Main Menu** use and to highlight **Panel Setup** and press or (OK).
- B. Use and to highlight **Load Setup** and press or (OK).
- C. Use and to highlight **Load Type Setup** and press or (OK).
- D. The Load Type Setup screen lists all the circuits. For each circuit, use and to select the circuit and and to select the load type.

Load type options depend on the module type assigned to the circuit:

Switching: Non-dim, Tridonic DSI, 0-10 V, DALI, PWM, 10-0 V, DALI LOG, DSI LOG

Dimming: Incandescent, MLV (Magnetic Low Voltage), Tu-Wire (ballasts), Neon, ELV (Electronic Low Voltage), Non-dim, Tridonic DSI, DSI LOG, 0-10 V, 10-0 V, DALI, DALI LOG, PWM, FDB (spec-grade only), auto detect (4A only)

Motors: Motor

Fans: Fan

Note: Switching or dimming modules controlling Tridonic DSI, DSI LOG, 0-10 V, 10-0 V, DALI, DALI LOG, or PWM load types require TVM(s).

- E. When all the load types are set press or (Done).

Load Type setup is now complete and all settings are saved in the event of a power failure.

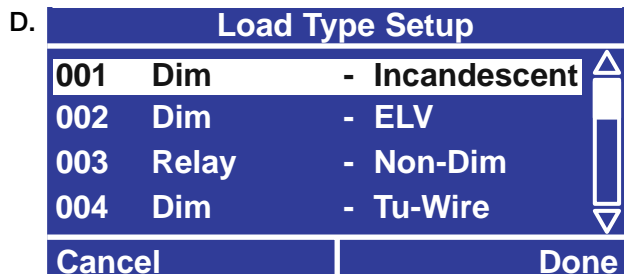
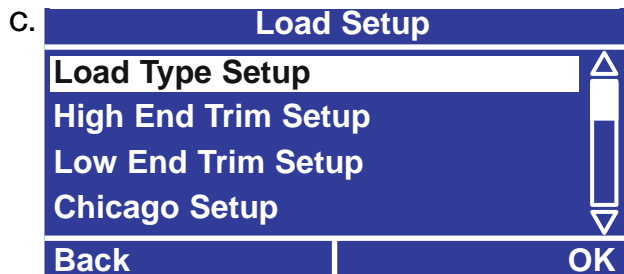
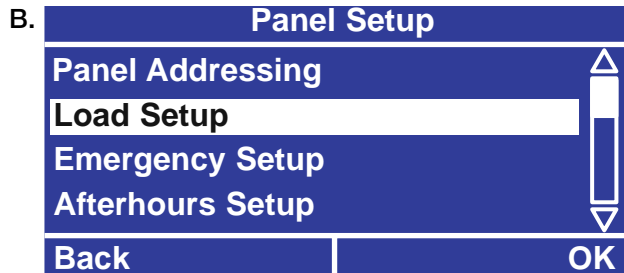

Caution! Failure to correctly assign load types may damage loads, especially certain electronic transformers, electronic ballasts, and motors. Verify with the transformer or ballast manufacturer that the product can be dimmed with phase control dimming before setting to any load type other than Non-Dim.



STEP 1 (continued)

High/Low End Trim Setup

High and low end trim settings limit the maximum and minimum output of a dimming circuit. Levels are set automatically when the load type is assigned. You should change the high or low end trim for a circuit only if the default setting needs to be adjusted.

- A. From the **Main Menu** use and to highlight **Panel Setup** and press or (OK).
- B. Use and to highlight **Load Setup** and press or (OK).
- C. Use and to highlight **High End Trim Setup** or **Low End Trim Setup** and press or (OK).
- D. For each dimming circuit, use and to select the circuit and and to set the trim level. Non-dimming, motor, and fan circuits are set to NA (not any).
- E. When all the trim levels are set press or (Done).

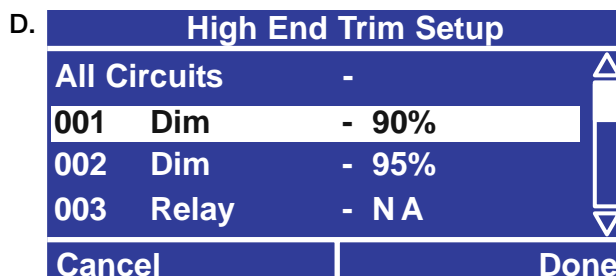
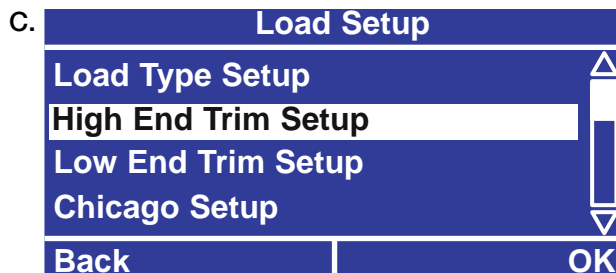

Caution! Do not reduce the low end trim on a fluorescent load type. This will decrease lamp life and may damage ballasts.



STEP 1 (continued)

Chicago Setup

This function is used to meet electrical installation codes in the city of Chicago, IL (USA). This setting limits how low a light level can be, including the levels in the “off” scene. This setting can be changed to a value from 10% to 60%, in 1% increments.

- A. From the **Main Menu** use and to highlight **Panel Setup** and press or (OK).
- B. Use and to highlight **Load Setup** and press or (OK).
- C. Use and to highlight **Chicago Setup** and press or (OK).
- D. Use and to select a circuit and and to set the Chicago limit. When all the circuit limits are set press or (Done).

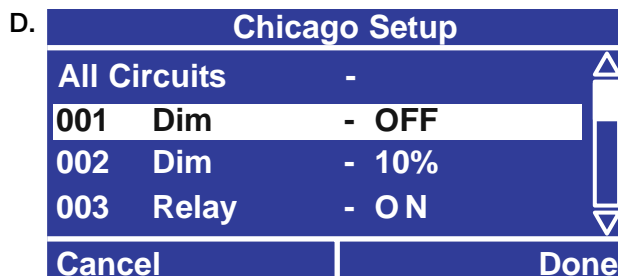
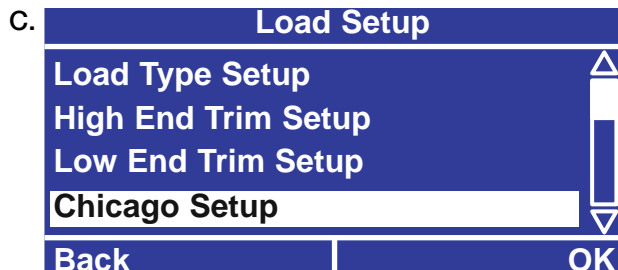



STEP 2

Time Clock Configuration

The *LCP128* system can be programmed to initiate scenes and other actions automatically at either a specific time of day or at a time relative to sunrise or sunset. It is important to configure the time clock as needed for your location.

Time clock configuration includes:

- Selecting a time format (12 or 24 hour).
- Setting the time.
- Setting the date.
- Setting the location, either by country/city or longitude/latitude.
- Adjusting sunrise and sunset times to accommodate special circumstances.
- Selecting whether to use daylight savings time and, if so, what rules to use.



STEP 2 (continued)

Time Format

- From the **Main Menu** use and to highlight **Time Clock Setup** and press or (OK).
- Use and to highlight **Setup Clock** and press or (OK).
- Use and to highlight **Time Format** and press or (OK).
- Use and to specify **24 Hr.** or **AM / PM** (12 Hr). Press or (Done) to save changes.

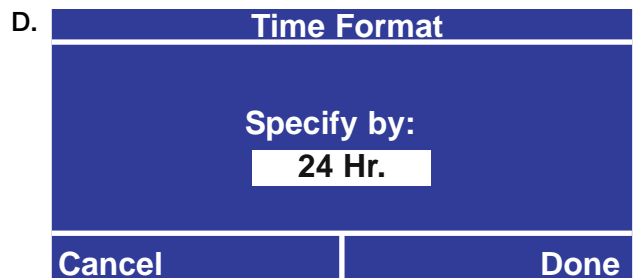
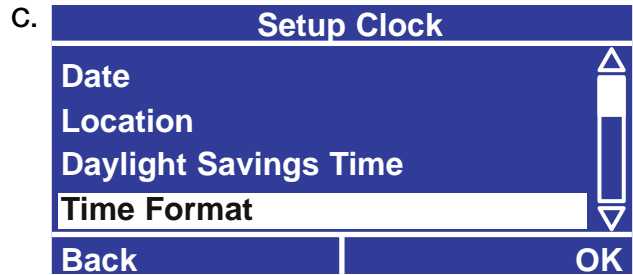

Time

- From the **Setup Clock** menu use and to highlight **Time** and press or (OK).
- Use and to change the current time. Use and to alternate between hours and minutes.
- Press or (Done) to save changes.

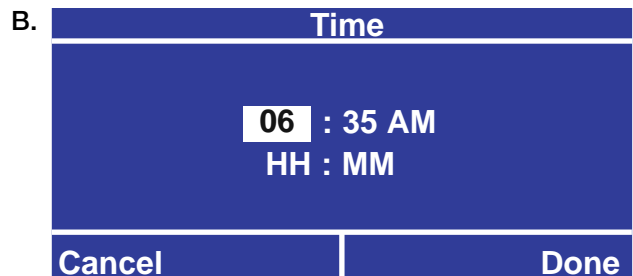

Date

- From the **Setup Clock** menu use and to highlight **Date** and press or (OK).
- Use and to change the current date. Use and to change between month, day, and year. The first 2 digits are the month, the middle 2 are the day, and the last 4 are the year.
- Press or (Done) to save changes.

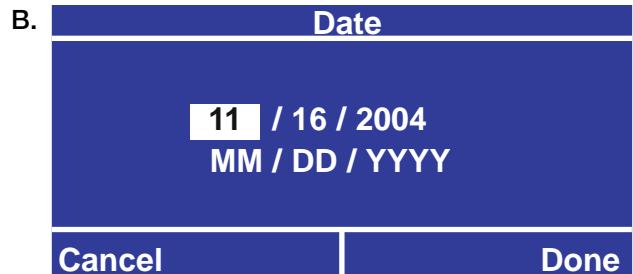



STEP 2 (continued)

Location

Note: Location must be set if using time clock events relative to sunrise or sunset.

- A. From the **Setup Clock** menu use and to highlight **Location** and press or (OK).
- B. Use and to select whether you want to set the location by country and city (recommended) or by latitude and longitude (if there are no nearby cities listed). Press or (OK) when done.

B. **Set Location Method**

Country, City

Latitude, Longitude

Back OK

If Setting by Country and City

- C. Use and to select the **Country** then press or (Next).
In the USA, use and to select the **State** then press or (Next).
- D. Use and to select the **City** then press or (Next).

C. **Set Country**

USA

Austria

Belgium

China

Cancel Next

If Setting by Latitude and Longitude

- C. Use and to select the digit and use and to set the latitude and longitude of your location in degrees and press or (Next).
- D. Use and to select the time zone for this location and press or (Next). Values are listed as an offset from Greenwich Mean Time.

Example: If your location is 39 degrees 36 minutes north, enter 39.6N degrees. The minutes are converted to a decimal of a degree by dividing by 60.

C. **Specify Latitude, Longitude**

Latitude Longitude

39 . 6 N 075 . 1 W

(DEGREES) (DEGREES)

Cancel Next

D. **Set Time Zone**

GMT -5:00 Eastern Time

GMT -4:00 Atlantic Time

GMT -3:30 Newfoundland

GMT -3:00 Brasilia

Previous Next



STEP 2 (continued)

Location (continued)

Entering Custom Country and City

- E. To enter a custom country name, use and to select each letter, then press to advance and enter the next letter. Use to go back and change any letter. Press or (Next) to continue.
- F. To enter a custom city name, use and to select each letter, then press to advance and enter the next letter. Use to go back and change any letter. Press or (Next) to continue.

Adjusting Sunrise and Sunset

- G. If needed, use this feature to shift your location's sunrise and sunset times by a fixed amount. This can be useful if there is a geographic feature (such as a mountain) that offsets the sunrise or sunset time for your location by a fixed amount. This can also be used to shift all time clock events that are relative to sunrise and sunset after they have been programmed.
If no offset is required, leave the offsets at 0:00 (default). Press or (Done) to save changes.

Note: Do not use this function to compensate for daylight savings time. For procedures on how to program daylight savings time settings, refer to the next page.

E. **Enter Country**

Custom Country Name

USA

Back Next

F. **Enter City**

Custom City Name

Coopersburg

Back Next

G. **Adjust Sunrise / Sunset**

Sunrise	Sunset
+ 00 : 00	+ 00 : 00

Previous Done



STEP 2 (continued)

Daylight Savings Time

Use this feature to set whether or not your location uses daylight savings time. If it does, you can configure when it starts and ends. When daylight savings time is used, the time will change automatically.

- A. From the **Setup Clock** menu use and to highlight **Daylight Saving Time** and press or (OK).
- B. Use and to set whether or not your location uses daylight savings time, then press or (Next).
- C. If your location follows the **United States** rules for daylight savings time then select United States. Otherwise select **Other**. Press or (Done) to save changes.
- D. If you select **Other**, you are prompted to enter the rules. The default rules are set based on your location. You will need to know:
 - The start month, week, and day.
 - The end month, week, and day.
 - The number of minutes to adjust for daylight savings time, up to 120 minutes.

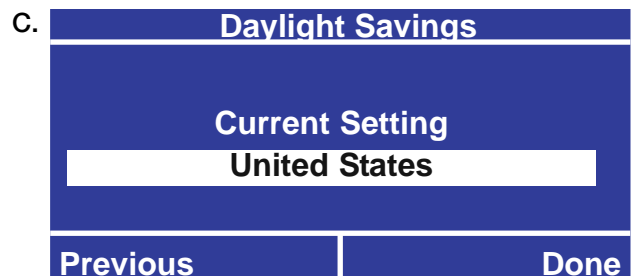
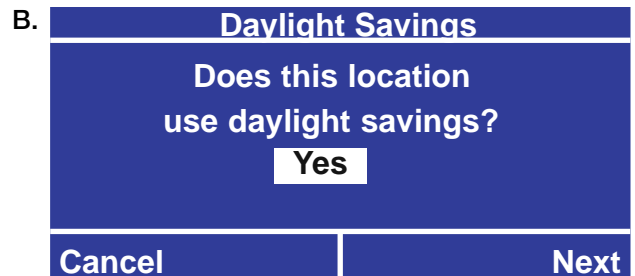
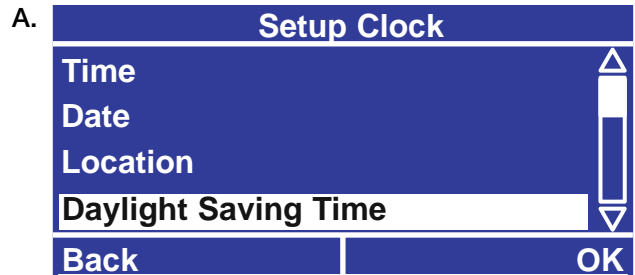



STEP 3

Scene Modification

Scenes are stored lighting levels for each circuit in your system. Scenes can be used to create different lighting effects using a programmed mix of dimming and switching settings.

The *LCP128* system comes with 32 pre-configured scenes and 1 Off scene (see the table below for default scene settings). As you program your system, you can assign these scenes to time clock events. For example, at 6 PM each evening certain dimming circuit levels rise and additional circuits turn on. You can also assign scenes to control station inputs (wallstation buttons, key switches, and contact closures). This way, any time a button is pressed, key is turned, or contact closure is made, the system activates the desired scene.

In STEP 3, you can modify the preconfigured scenes as needed to create your own specific lighting environments.

Note: In STEPS 4 and 5, you can also create additional custom scenes associated with a specific timeclock event or control station input.

Scene	Default Settings for Dimming Circuits	Default Settings for Switching Circuits
Off	OFF	OFF
1	100%	ON
2	75%	ON
3	50%	ON
4	25%	ON
5 to 32	100%	ON



STEP 3 (continued)

Modify Scenes

- A. From the **Main Menu** use and to highlight **Scene Setup** and press or (OK).
- B. The Scene Modification screen lists the preconfigured scenes stored in your system. Use and to choose the scene you want to modify and press or (Next).

Note: Modified scenes will reflect changes in real time.

- C. The system lists each circuit and its current setting for this scene. Use and to select a circuit and and to change the setting for that circuit. To simultaneously change all circuits, select **All Circuits** and use and to change the setting.

Note: The **All Circuits** function enables you to simultaneously adjust the percentage for all dimming circuits or to turn all circuits off or on.

Scene circuit settings depend on the circuit type:

Switching: ON, OFF, --- (unaffected)

Dimming: OFF, 1 - 100%, --- (unaffected)

Motors: Open, Close, Stop, Jog Up, Jog Down, --- (unaffected)

Fans: Low, Medium, Medium-High, High, --- (unaffected)

Note: The --- (**unaffected**) setting means that the circuit is not affected by this scene.

When you are finished modifying the scene press or (Next).

- D. For dimming circuits affected by the scene, use and to set a fade time and press or (Next).
- E. For a combination of dimming and switching circuits, use and to set whether switches react at **Start of Fade** or **End of Fade**. Then press or (Done).

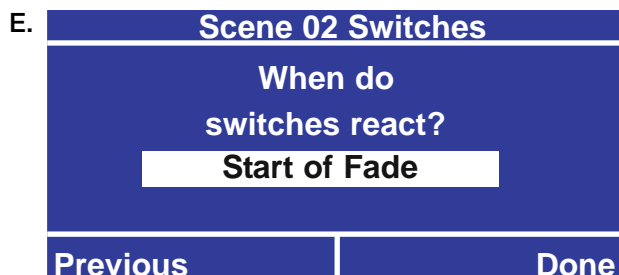
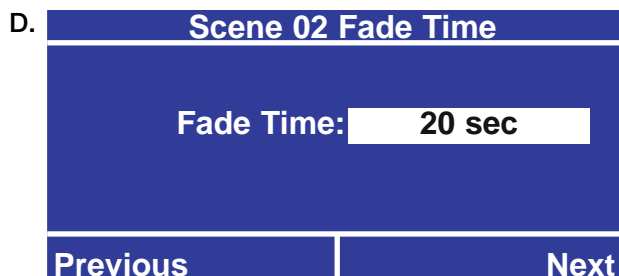
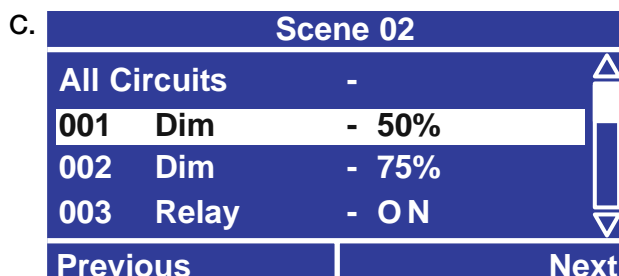
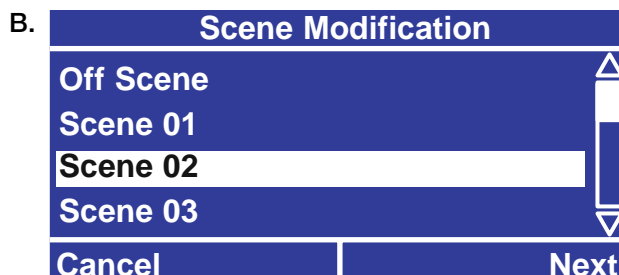



STEP 4

Control Stations

Control stations are connected to the *LCP128* panel via the digital control link. Control stations can be wallstations (with various numbers of buttons), key switches (NTOMX-KS), contact closure input and output devices (OMX-AV, OMX-WCI), contact closure output devices (OMX-CCO-8), OMX-RS232 interfaces, or theatrical controls (ODMX-512). Each control station must be assigned a unique address. Addressing may be found in either the appropriate panel installation guide or installation guides for the individual devices. To set the address, refer to the instructions for each device.

Every wallstation button, key switch, or contact closure input can be assigned one of the following functions:

- **Scene** - A scene consists of a specified light level and fade time. Each time the button, key switch, or contact closure input is activated, the assigned circuits go to the programmed scene. A scene can also be used to control contact closure outputs.
- **Custom Scene** - A custom scene is a scene assigned to and programmed for a specific button press, key switch turn, or contact closure input. A custom scene may be recalled only by that single action to which it is assigned.
- **Lower Circuits** - Assigned dimming circuits are progressively lowered as long as input is received from the control station (for example, the button is held down, key is turned, contact closure is maintained). Circuits stay at this setting until another event or control station input occurs.
- **Raise Circuits** - Assigned dimming circuits are progressively raised as long as input is received from the control station (for example, the button is held down, key is turned, contact closure is maintained). Circuits stay at this setting until another event or control station input occurs.
- **Toggle** - Each time the button, key switch, or contact closure input is activated, the assigned circuits toggle between on and off. If the assigned circuits are in a mixed state (some on and some off), the circuits turn on.
- **Delay To Off** - Each time the button, key switch, or contact closure input is activated, the assigned circuit(s) turn off after the preset amount of time (1 - 90 minutes).
- **Enable Time Clock** - Enable the function of the time clock.
- **Disable Time Clock** - Disable the function of the time clock.

Before proceeding with STEP 4, complete the Control Station Table at the back of this guide. Record what each input (button, key switch, or contact closure) on each control station should do.

Note: In STEP 4, you will configure contact closure inputs wired to a Lutron OMX-AV control station. Contact closure inputs wired directly to a panel are configured later in STEP 6.

Factory Settings

When a control station type is not programmed in the system, the *LCP128* uses an algorithm to intelligently guess the control station type, based on the button(s) pressed. Pressing the button(s) on a control station allows the *LCP128* to identify it; some control stations can be identified with fewer or no button presses. Once the *LCP128* has identified the control station, it assigns it the following defaults (note that these can be reprogrammed as desired):











- All button actions affect all circuits, and button presses select scenes
- All raise/lower actions raise and lower all circuits (non-dim loads set to 0% or 100%)
- Buttons labeled OFF are assigned to the OFF scene; if there is no labeled OFF button, the last button is assigned to OFF
- Button 1 is assigned to scene 1, button 2 is assigned to scene 2, and so on until the last (OFF) button
- For single-button control stations, the button toggles all circuits on and off
- Once any control station is programmed by the *LCP128*, the default settings are bypassed
- If all control station addresses are set to NO STATION, the system reverts to the factory defaults

For button numbers on various control stations, see the section that follows.

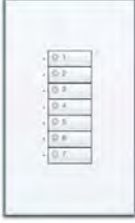

STEP 4 (continued)













Control Station Button Map: Factory Presets

Button Number/Action	Model Number(s)/ Program as	Button Number/Action	Model Number(s)/ Program as
 Toggle	S0-1B S0-1B0 1-button control	 1: Scene 1 2: Scene 2 3: Scene 3 4: Scene 4 5: Off	S0-5B S0-5B0 5-button control
 1: Scene 1 2: Off	S0-2B S0-2B0 2-button control	 1: Scene 1 2: Scene 2 3: Scene 3 4: Scene 4 5: Scene 5 6: Off	S0-6B S0-6B0 6-button control
 1: Scene 1 2: Scene 2 3: Off	S0-3B S0-3B0 3-button control	 1: Scene 1 2: Scene 2 3: Scene 3 4: Scene 4 5: Scene 5 6: Scene 6 7: Off	S0-7B S0-7B0 7-button control
 1: Scene 1 2: Scene 2 3: Scene 3 4: Off	S0-4B S0-4B0 4-button control	 Toggle	F0MX-1B F0MX-1B-SL 1-button control
 1: Scene 1 2: Scene 2 3: Scene 3 4: Scene 4 5: Off	S0-4NRL S0-4NRLO 5-button control	 1: Scene 1 2: Off	NT0MX-2B 2-button control
 1: Scene 1 2: Scene 2 3: Scene 3 4: Scene 4 5: Off Lower All Raise All	S0-4S S0-4SIR S0-4SD S0-4SIRO 5-button with raise/lower	 Clockwise: Scene 1 Counter-clockwise: Off	OMX-KS Keyswitch



STEP 4 (continued)

Control Station Button Map: Factory Presets

Button Number/Action	Model Number(s)/ Program as	Button Number/Action	Model Number(s)/ Program as
 <p>1: Scene 1 2: Scene 2 3: Scene 3 4: Scene 4 5: Off Up: Raise Down: Lower</p>	<p>NTOMX-4S-NRL NTOMX-4S-IR</p> <p>5-button with raise/lower</p>	 <p>1: Scene 1 4: Scene 4 2: Scene 2 5: Scene 5 3: Scene 3 6: Off</p>	<p>NTOMX-LB6 NTOMX-LB6-RL</p> <p>6-button control</p>
 <p>1: Scene 1 2: Off</p>	<p>EOMX-2B</p> <p>2-button control</p>	 <p>1: Scene 1 4: Scene 4 7: Scene 7 2: Scene 2 5: Scene 5 8: Scene 8 3: Scene 3 6: Scene 6 9: Off</p>	<p>NTOMX-LB9 NTOMX-LB9-RL</p> <p>9-button control</p>
 <p>1: Scene 1 2: Scene 2 3: Scene 3 4: Off</p>	<p>EOMX-4B</p> <p>4-button control</p>	 <p>1: Scene 1 2: Off</p>	<p>OMX-2B-DW</p> <p>2-button control</p>
 <p>1: Scene 1 2: Scene 2 3: Scene 3 4: Off Lower All Raise All</p>	<p>EOMX-4S EOMX-4S-IR</p> <p>5-button with raise/lower</p>	 <p>1: Scene 1 2: Scene 2 3: Scene 3 4: Scene 4 5: Off 6: Raise All 7: Lower All</p>	<p>OMX-7B-DW</p> <p>5-button with raise/lower</p>
 <p>1-4 Scene 1-4 5-8 Scene 5-8 Lower All Raise All</p>	<p>EOMX-8S EOMX-8S-IR</p> <p>9-button with raise/lower</p>	 <p>1: Scene 1 2: Scene 2 3: Scene 3 4: Scene 4 5: Off Up: Raise All Down: Lower All</p>	<p>OMX-4SLB-DW</p> <p>5-button with raise/lower</p>
 <p>1: Scene 1 2: Scene 2 3: Scene 3 4: Scene 4 5: Off 7: Raise 6: Lower</p>	<p>NTOMX-KP5</p> <p>5-button with raise/lower</p>		
 <p>1: Scene 1 7: Scene 6 2: Scene 2 8: Scene 7 3: Scene 3 9: Scene 8 4: Scene 4 10: Scene 9 5: Scene 5 11: Off 6: Raise 12: Lower</p>	<p>NTOMX-KP10</p> <p>10-button with raise/lower</p>		
 <p>1: Scene 1 7: Scene 6 12: Scene 11 2: Scene 2 8: Scene 7 13: Scene 12 3: Scene 3 9: Scene 8 14: Scene 13 4: Scene 4 10: Scene 9 15: Scene 14 5: Scene 5 11: Scene 10 16: Off 6: Raise All 17: Lower All</p>	<p>NTOMX-KP15</p> <p>15-button with raise/lower</p>		



STEP 4 (continued)

Configure the Wallstations

- A. From the **Main Menu** use and to highlight **Control Station Setup** and press or (OK).
- B. Use and to choose the **Address** of the wallstation you would like to configure and press or (Next).
- Note:** The wallstation Address selected must match the Address switch setting on the wallstation.
- C. Use and to set the **Type** to **Wall Station** and press or (Next).
- D. Use and to select whether the station has **Permanent Raise and Lower Buttons** and press or (Next).
- E. Use and to set the **Number** of buttons and press or (Next).
- Note:** Do not count raise/lower buttons.
- F. Use and to select the **Button** you want to program and press or (Next).
- Note:** To configure contact closure inputs (CCI), see page 35.
- G. Use and to select the type of **Action** for this button: **Lower Circuits, Raise Circuits, Scene, Custom Scene, Enable Time Clock, Disable Time Clock, Delay to Off, Toggle, or No Action** and press or (Next).
- Refer to the following pages to program each type of action.

B. **Control Station Setup**

Address 01
Address 02
Address 03
Address 04

Cancel Next

C. **Address 03 Setup**

Type: **Wall Station**

Previous Next

E. **Address 03 Setup**

Number of Buttons: **03**

Previous Next

F. **Address 01 Setup**

Button 01
Button 02
Button 03
CCI 1

Previous Next

G. **Address 03 Button 01**

Action: **Lower Circuits**

Previous Next



STEP 4 (continued)

Configure the Wallstations (continued)

If Selecting a Scene Action

- H. In step G, if you selected **Scene**, use and to select the scene and press or (Done).

H. **Select Scene**

Scene:

Previous Done

If Selecting a Custom Scene Action

- H. In step G, if you selected **Custom Scene**, the Select Circuits screen lists all the circuits. Use and to select a circuit and and to change the setting for that circuit. Or to simultaneously change all circuits, select **All Circuits** and use and to change the setting.

Note: The **All Circuits** function enables you to simultaneously adjust the percentage for all dimming circuits or to turn all circuits off or on.

Circuit settings depend on the circuit type:

Switching: ON, OFF, --- (unaffected)

Dimming: OFF, 1 - 100%, --- (unaffected)

Motors: Open, Close, Stop, Jog Up, Jog Down

Fans: Low, Medium, Medium-High, High

Note: The --- (unaffected) setting means the circuit is not affected by this scene.

When the circuits are programmed for this custom scene press or (Next).

- I. The Select CCO Address screen is displayed only if control station devices with contact closure outputs (OMX-AV or OMX-CCO-8) have been entered into the system.

Use and to select the output to be associated with the button being programmed. Use and to change the setting for that output: **maintained open**, **maintained close**, **momentary pulse**, or --- (unaffected). When the outputs are programmed for this custom scene, press or (Done).

- J. For dimming circuits affected by the custom scene, use and to set the **Fade Time** and press or .

- K. For a combination of dimming and switching circuits, use and to set when the switches react (**Start of Fade** or **End of Fade**). Then press or .

H. **Select Circuits**

All Circuits	- ---
001 Dim	- 10%
002 Dim	- 20%
003 Relay	- ON

Previous Next

I. **Select CCO Address**

A01 CCO1	- Maintained Open
A01 CCO2	- ---
A01 CCO3	- ---
A01 CCO4	- ---

Previous Done

Address number Contact closure output number

J. **Custom Scene Fade Time**

Fade Time:

Previous Next

K. **Custom Scene Fade Time**

When do switches react?

Previous Done



STEP 4 (continued)

Configure the Wallstations (continued)

If Selecting a Delay to Off Action

- H. In step G, if you selected **Delay to Off**, use and to set the **Time to Off** and press or .
- I. The Assign Circuits screen lists all the circuits. Unassigned circuit numbers have hash lines going through them. Move the cursor to a circuit number and press to toggle between **Assigned** and **Unassigned** (dashed). All circuits can be toggled by selecting **ALL Circuits** and pressing . When the circuits are programmed press .
- J. For dimming circuits affected by the action, use and to set the **Fade Time** and press or .
- K. For a combination of dimming and switching circuits, use and to set when the switches react (**Start of Fade** or **End of Fade**). Then press or .

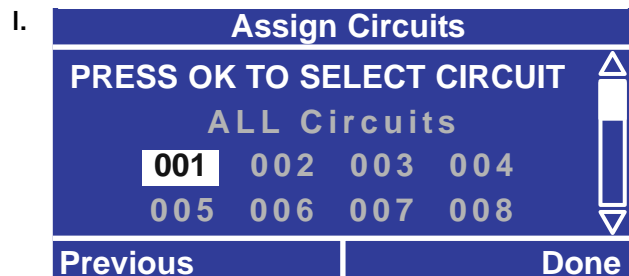
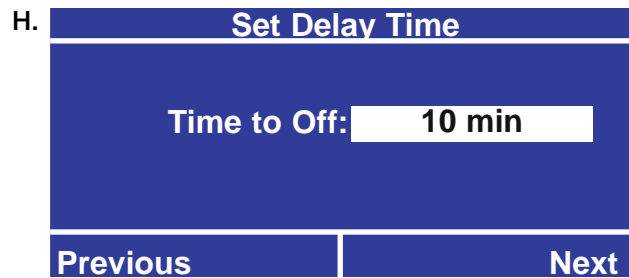

If Selecting a Lower Circuits, Raise Circuits, or Toggle Action

- H. In step G, if you selected **Lower Circuits**, **Raise Circuits**, or **Toggle**, the Assign Circuits screen lists all the circuits. Unassigned circuits are presented as numbers with hash lines going through them. Move the cursor to a circuit number and press to toggle between **Assigned** and **Unassigned** (dashed). All circuits can be toggled by selecting **ALL Circuits** and pressing . When the circuits are programmed press .
- I. For dimming circuits affected by the action, use and to set the **Fade Time**.
- J. For a combination of dimming and switching circuits, use and to set when the switches react (**Start of Fade** or **End of Fade**). Then press or .

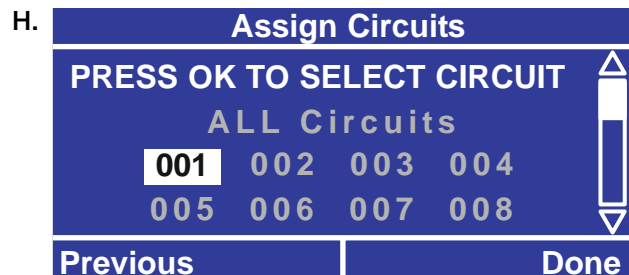



STEP 4 (continued)

Configure Contact Closure Inputs for *seeTouch* Wallstations

- A. From the **Main Menu** use and to highlight **Control Station Setup** and press or (OK).
- B. Use and to choose the **Address** of the wallstation you would like to configure and press or (Next).
Note: The wallstation Address selected must match the Address switch setting on the wallstation.
- C. Use and to set the **Type** to **Wall Station** and press or (Next).
- D. Use and to select whether the station has **Permanent Raise and Lower Buttons** and press or (Next).
- E. Use and to set the **Number** of buttons and press or (Next).
Note: Do not count raise/lower buttons.
- F. Use and to select the **Contact Closure Input (CCI)** you want to program and press or (Next).
- G. Use and to select whether you want to define an action for when the contact **Opens** or **Closes** and press or (Next).
- H. Use and to choose the type of **Action** for the CCI and press or (Done).

B. **Control Station Setup**

Address 01	
Address 02	
Address 03	
Address 04	
Previous	Next

C. **Address 01 Setup**

Type: Wall Station	
Previous	Next

F. **Address 01**

Button 1	
Button 2	
CCI 1	
CCI 2	
Previous	Next

G. **CCI 01 Setup**

Open Action	
Closure Action	
Previous	Next

H. **Address 01** **CCI 01**

Action: Scene	
Previous	Done



STEP 4 (continued)

Configure the OMX-CIR

- A. From the **Main Menu** use **▲** and **▼** to highlight **Control Station Setup** and press **OK** or **Ⓜ** (OK).
- B. Use **▲** and **▼** to choose the **Address** of the wallstation you would like to configure and press **OK** or **Ⓜ** (Next).
- Note:** The wallstation Address selected must match the Address switch setting on the OMX-CIR.
- C. Use **▲** and **▼** to set the **Type** to **Wall Station** and press **OK** or **Ⓜ** (Next).
- D. Use **▲** and **▼** to select the **Button** you want to program and press **OK** or **Ⓜ** (Next).
- E. Use **▲** and **▼** to select the type of **Action** for this button: **Lower Circuits, Raise Circuits, Scene, Custom Scene, Enable Time Clock, Disable Time Clock, Delay to Off, Toggle, or No Action** and press **OK** or **Ⓜ** (Next).
- Refer to the following pages to program each type of action.

B. **Control Station Setup**

Address 01	
Address 02	
Address 03	
Address 04	
Cancel	Next

C. **Address 03 Setup**

Type: OMX-CIR	
Previous	Next

D. **Address 01 Setup**

Lower Button	
Raise Button	
Button 01	
Button 02	
Previous	Next

E. **Address 03 Button 01**

Action: Toggle	
Previous	Next



STEP 4 (continued)

Configure the OMX-CIR (continued)

If Selecting a Scene Action

- F. In step E, if you selected **Scene**, use ▲ and ▼ to select the scene and press ⏎ or ⌘ (Done).

F. **Select Scene**

Scene:

Previous Done

If Selecting a Custom Scene Action

- F. In step E, if you selected **Custom Scene**, the Select Circuits screen lists all the circuits. Use ▲ and ▼ to select a circuit and ◀ and ▶ to change the setting for that circuit. Or to simultaneously change all circuits, select **All Circuits** and use ◀ and ▶ to change the setting.

Note: The **All Circuits** function enables you to simultaneously adjust the percentage for all dimming circuits or to turn all circuits off or on.

Circuit settings depend on the circuit type:

Switching: ON, OFF, --- (unaffected)

Dimming: OFF, 1 - 100%, --- (unaffected)

Motors: Open, Close, Stop, Jog Up, Jog Down

Fans: Low, Medium, Medium-High, High

Note: The --- (unaffected) setting means the circuit is not affected by this scene.

When the circuits are programmed for this custom scene press ⏎ or ⌘ (Next).

- G. The Select CCO Address screen is displayed only if control station devices with contact closure outputs (OMX-AV or OMX-CCO-8) have been entered into the system.

Use ▲ and ▼ to select the output to be associated with the button being programmed. Use ◀ and ▶ to change the setting for that output: **maintained open**, **maintained close**, **momentary pulse**, or --- (unaffected). When the outputs are programmed for this custom scene, press ⏎ or ⌘ (Done).

- H. For dimming circuits affected by the custom scene, use ▲ and ▼ to set the **Fade Time** and press ⏎ or ⌘.

- I. For a combination of dimming and switching circuits, use ▲ and ▼ to set when the switches react (**Start of Fade** or **End of Fade**). Then press ⏎ or ⌘.

F. **Select Circuits**

All Circuits	- ---
001 Dim	- 10%
002 Dim	- 20%
003 Relay	- ON

Previous Next

G. **Select CCO Address**

A01 CCO1	- Maintained Open
A01 CCO2	- ---
A01 CCO3	- ---
A01 CCO4	- ---

Previous Done

Address number Contact closure output number

H. **Custom Scene Fade Time**

Fade Time:

Previous Next

I. **Custom Scene Fade Time**

When do switches react?

Previous Done



STEP 4 (continued)

Configure the OMX-CIR (continued)

If Selecting a Delay to Off Action

- F. In step E, if you selected **Delay to Off**, use and to set the **Time to Off** and press or .
- G. The Assign Circuits screen lists all the circuits. Unassigned circuit numbers have hash lines going through them. Move the cursor to a circuit number and press to toggle between **Assigned** and **Unassigned** (dashed). All circuits can be toggled by selecting **ALL Circuits** and pressing . When the circuits are programmed press .
- H. For dimming circuits affected by the action, use and to set the **Fade Time** and press or .
- I. For a combination of dimming and switching circuits, use and to set when the switches react (**Start of Fade** or **End of Fade**). Then press or .

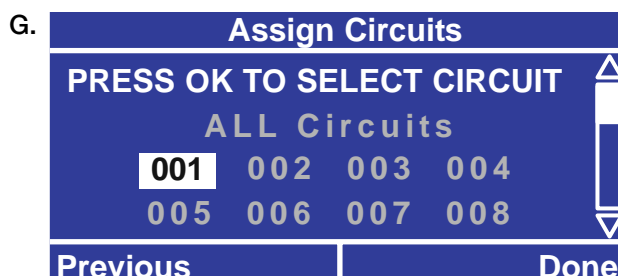
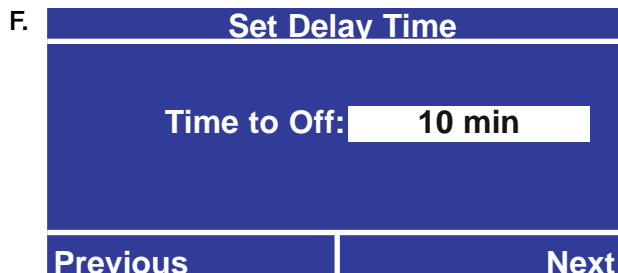

If Selecting a Lower Circuits, Raise Circuits, or Toggle Action

- F. In step E, if you selected **Lower Circuits, Raise Circuits**, or **Toggle**, the Assign Circuits screen lists all the circuits. Unassigned circuits are presented as numbers with hash lines going through them. Move the cursor to a circuit number and press to toggle between **Assigned** and **Unassigned** (dashed). All circuits can be toggled by selecting **ALL Circuits** and pressing . When the circuits are programmed press .
- G. For dimming circuits affected by the action, use and to set the **Fade Time**.
- H. For a combination of dimming and switching circuits, use and to set when the switches react (**Start of Fade** or **End of Fade**). Then press or .

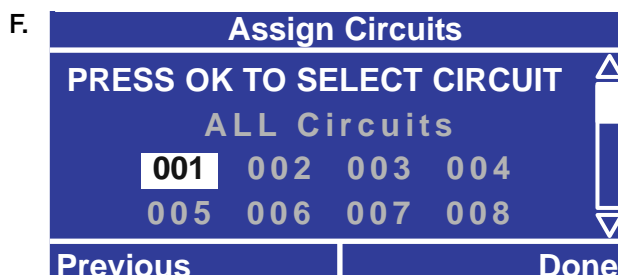



STEP 4 (continued)

Configure Key Switch (NTOMX-KS)

Lutron's NTOMX-KS key switch control station can be programmed to initiate an action for a clockwise and counter-clockwise turn.

- From the **Main Menu** use and to highlight **Control Station Setup** and press or (OK).
- Use and to highlight the address of the **NTOMX-KS** you would like to configure and press or (Next).
- Use and to change control type to **Key Switch** and press or (Next).
- Use and to highlight which direction turn to program and press or (Next). Each key switch can be programmed for a clockwise or counter-clockwise turn. Both may be programmed.
- Use and to select the type of **Action** for this key turn: **Lower Circuits, Raise Circuits, Scene, Custom Scene, Enable Time Clock, Disable Time Clock, Delay to Off, Toggle, and No Action** and press or (Next). Refer to the beginning of STEP 4 for an explanation of the various action types.
- Program the **Lower Circuits, Raise Circuits, Scene, Custom Scene, Delay to Off, or Toggle** action using the same screen methods used to configure a wallstation button. Refer to "Configure the Wallstations" earlier in STEP 4.

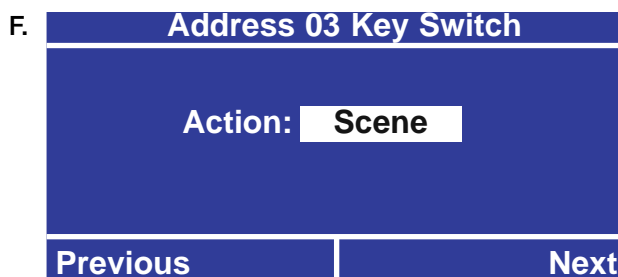
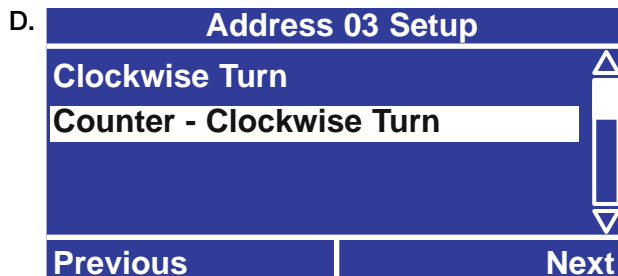
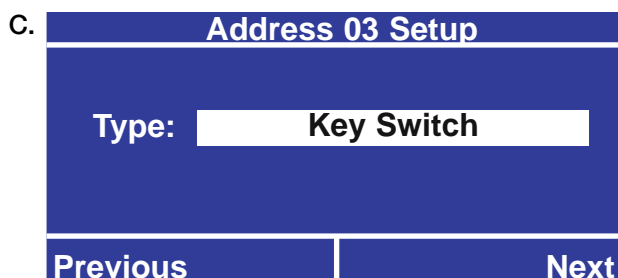
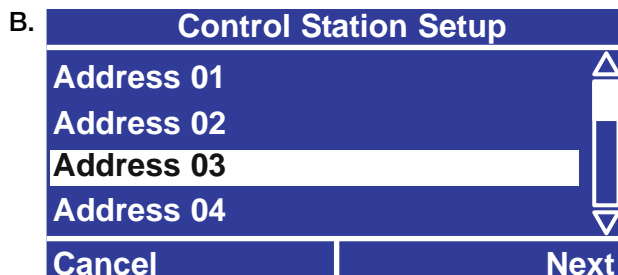
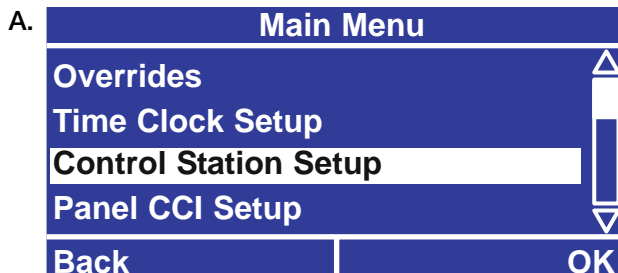



STEP 4 (continued)

Configure Contact Closure Inputs on OMX-AV/OMX-WCI

Lutron's OMX-AV or OMX-WCI control station can be programmed to initiate actions for up to five contact closure inputs.

Note: For contact closure inputs wired directly to the LCP128 panel, refer to STEP 6.

Note: OMX-WCI has 7 contact closure inputs.

- From the **Main Menu** use and to highlight **Control Station Setup** and press or (OK).
- Use and to highlight the address of the **OMX-AV** you would like to configure and press or (Next).
- Use and to set the control **Type** to **OMX-AV** and press or (Next).
- Each OMX-AV provides 5 inputs. Use and to highlight the **Contact Closure Input (CCI)** to program and press or (Next). Or select **No CCI's** if only the contact closure outputs (CCOs) are being used.
- Use and to select whether you want define an action for when the contact opens or when it closes and press or (Next).

Note: If there should be an action on both, first set up the **Open Action**, then follow this procedure again but choose **Closure Action**.
- Use and to select the type of **Action** for this CCI: **Lower Circuits**, **Raise Circuits**, **Scene**, **Custom Scene**, **Enable Time Clock**, **Disable Time Clock**, **Delay to Off**, **Toggle**, and **No Action** and press or (Next). Refer to the beginning of STEP 4 for an explanation of the various action types.
- For **OMX-WCI**: Program the **Lower Circuits**, **Raise Circuits**, **Scene**, **Custom Scene**, **Delay to Off**, or **Toggle** action using the same screen methods used to configure a wallstation button. Refer to "Configure the Wallstations" earlier in STEP 4.

For **OMX-AV**: Program the **Disable Time Clock**, **Enable Time Clock**, **Scene**, **Custom Scene**, **Delay to Off**, or **Toggle** action using the same screen methods used to configure a wallstation button. Refer to "Configure the Wallstations" earlier in STEP 4.

A. **Main Menu**

Overrides	
Time Clock Setup	
Control Station Setup	
Panel CCI Setup	
Back	OK

B. **Control Station Setup**

Address 01	
Address 02	
Address 03	
Address 04	
Previous	Next

C. **Address 03 Setup**

Type: OMX-AV	
Previous	Next

D. **Address 03 OMX-AV**

No CCI's	
CCI 01	
CCI 02	
CCI 03	
Previous	Next

E. **Address 03 CCI 2 Setup**

Open Action	
Closure Action	
Previous	Next



STEP 4 (continued)

Configure DMX Channels to Circuits on ODMX-512

Lutron's ODMX-512 control station can be programmed to 32 circuits in the system. The system can then take inputs from a theatrical stage console to assigned circuits in the system.

- From the **Main Menu** use and to highlight **Control Station Setup** and press or (OK).
- Use and to highlight the address of the **ODMX-512** you would like to configure and press or (Next).
- Use and to set the control **Type** to **ODMX-512** and press or (Next).
- Use and to select the **DMX Activation Mode** and press or (Next).

Note: The DMX can be activated either when in connection or when the selected channel is set above 50%.

- Use and to assign circuits to a DMX channel and press or (Next).

Note: The same DMX channel may be assigned to more than one circuit.

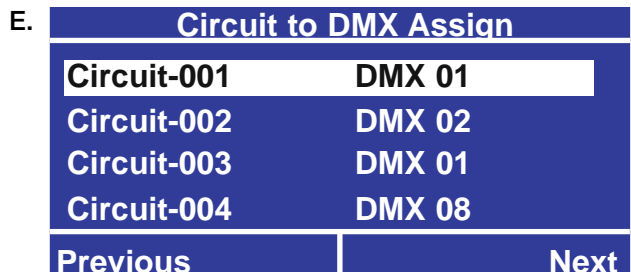
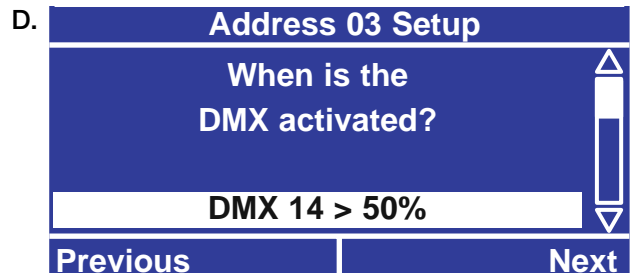
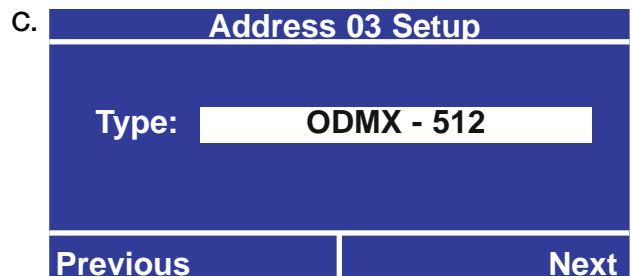
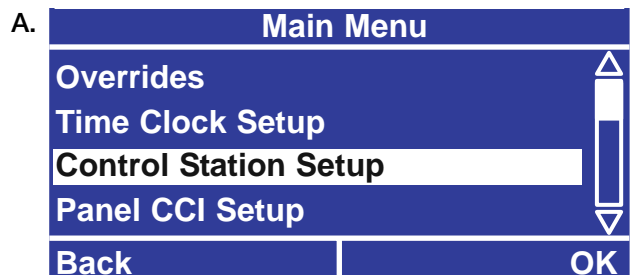



STEP 4 (continued)

Integration through RS232

Lutron's OMX-RS232 control station enables you to integrate your *LCP128* system with a building management system.

- From the **Main Menu** use and to highlight **Control Station Setup** and press or (OK).
- Use and to highlight the address of the **OMX-RS232/OMX-CI-RS232** you would like to configure and press or (Next).
- Use and to change control **Type** to **OMX-RS232 / OMX-CI-RS232** and press or (Done).

Using the GRAFIK 6000® RS232 protocol.

The OMX-RS232 is packaged and shipped with complete instructions and a protocol that details how to execute each command. Only a subset of the commands in that document work with the *LCP128* system and they are listed below:

Command LCP128 Function

Fade to Level:	Sets a pattern or time delay to off
Multilevel:	Flash circuits
Get Level:	Request level
Simulate Press:	Simulate button press
Simulate Release:	Simulate button release
Enable Control Stations:	Enable control stations
Disable Control Stations:	Disable control stations
Set Clock:	Sets time and date
Time Now:	Request time
Astro Times:	Request sunrise / sunset times
Date:	Request date
Enable Time clock:	Enable time clock
Disable Time clock:	Disable time clock

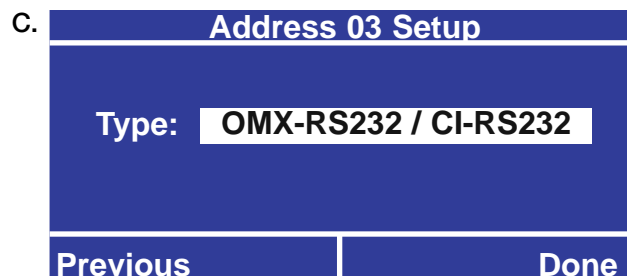
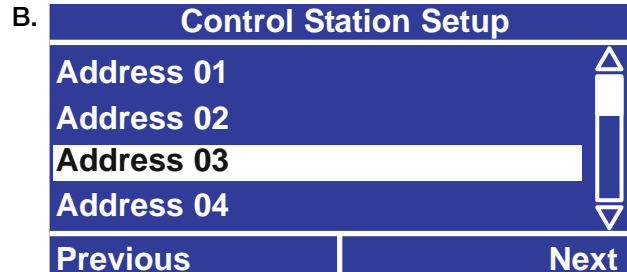
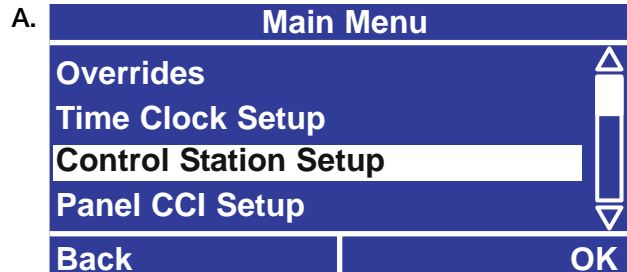



STEP 4 (continued)

Integration through Ethernet

Lutron's OMX-CI-NWK-E control station enables you to integrate your *LCP128* system with a building management system.

- From the **Main Menu** use and to highlight **Control Station Setup** and press or (OK).
- Use and to highlight the address of the **OMX-CI-NWK-E** you would like to configure and press or (Next).
- Use and to change control **Type** to **OMX-CI-NWK-E** and press or (Done).

Using the GRAFIK 6000® RS232 protocol.

The OMX-CI-NWK-E is packaged and shipped with complete instructions and a protocol that details how to execute each command. Only a subset of the commands in that document work with the *LCP128* system and they are listed below:

Command	LCP128 Function
Fade to Level:	Sets a pattern or time delay to off
Multilevel:	Flash circuits
Get Level:	Request level
Simulate Press:	Simulate button press
Simulate Release:	Simulate button release
Enable Control Stations:	Enable control stations
Disable Control Stations:	Disable control stations
Set Clock:	Sets time and date
Time Now:	Request time
Astro Times:	Request sunrise / sunset times
Date:	Request date
Enable Time clock:	Enable time clock
Disable Time clock:	Disable time clock

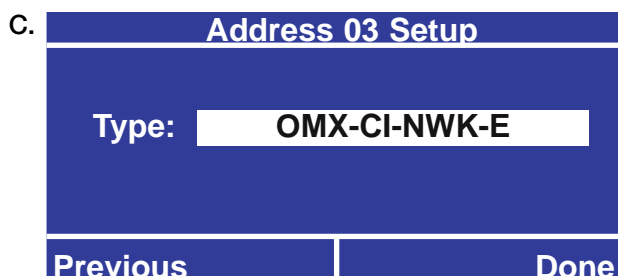
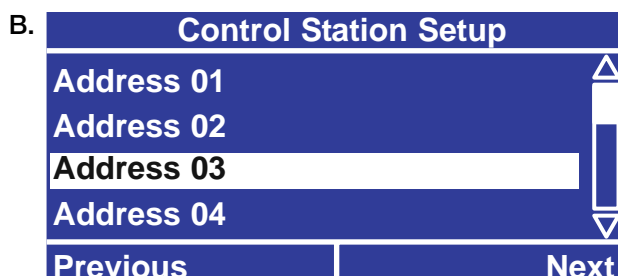
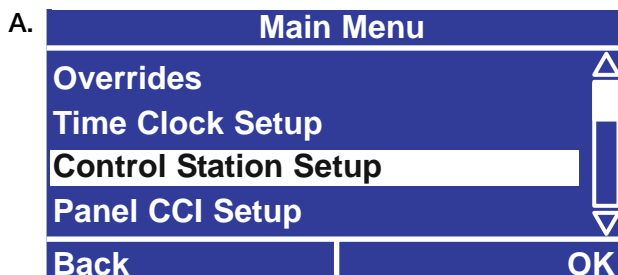



STEP 5

Time Clock Events

Time clock events enable the system to initiate a scene or start/end afterhours mode at either a specific time of day or at a time relative to sunrise or sunset. 47 schedules are available—one for every day of the week, and 40 holiday schedules. There can be a total of up to 500 events and no more than 25 on any day / holiday. Holiday schedules always override the weekly schedule.

The options for time clock events are:

- **Scene or Custom Scene** - The assigned circuits go to the programmed scene/custom scene settings.
- **Enable or Disable Controls** - Enable or disable the function of control stations.
- **Afterhours Start** - Starts an energy saving mode that is used to turn lights off at the end of normal hours until the beginning of the next day. First, a scene or pattern of circuit levels is recalled for the space (**Afterhours Start**). Circuits programmed to turn off flash to warn any occupants that they are about to go out (number of flashes specified by **Flash Count**). Lights remain on to allow the occupant a chance to press a button to keep lights on (length of time is programmed as **Off Delay**). Finally, if a button has not been pressed, lights turn off automatically at the end of the delay period.

If a button is pressed, occupancy sensor tripped, or another timeclock event occurs while the system is in **Afterhours** mode or in **Off Delay**, lights turn on and remain on for the programmed number of minutes, (**Warn Time**) then flash (number specified by **Flash Count**) and then turn off after the **Off Delay**.

- **Afterhours End** - When afterhours ends, the circuits are returned to their programmed state.

Example Scenario for Afterhours:

- Afterhours start event—afterhours scene is recalled. The circuits that are going to turn off start to flash and off delay starts counting down.
- System enters afterhours.
- Button is pressed to turn lights on.
- Lights flash notifying they will be turning off soon.
- Button is pressed to keep lights on.
- Lights flash notifying they will be turning off soon.
- Lights turn off.
- Afterhours end event.

Before proceeding with STEP 5, complete the Time Clock Event Table located at the back of this guide. Record when each event should occur and what it should do.

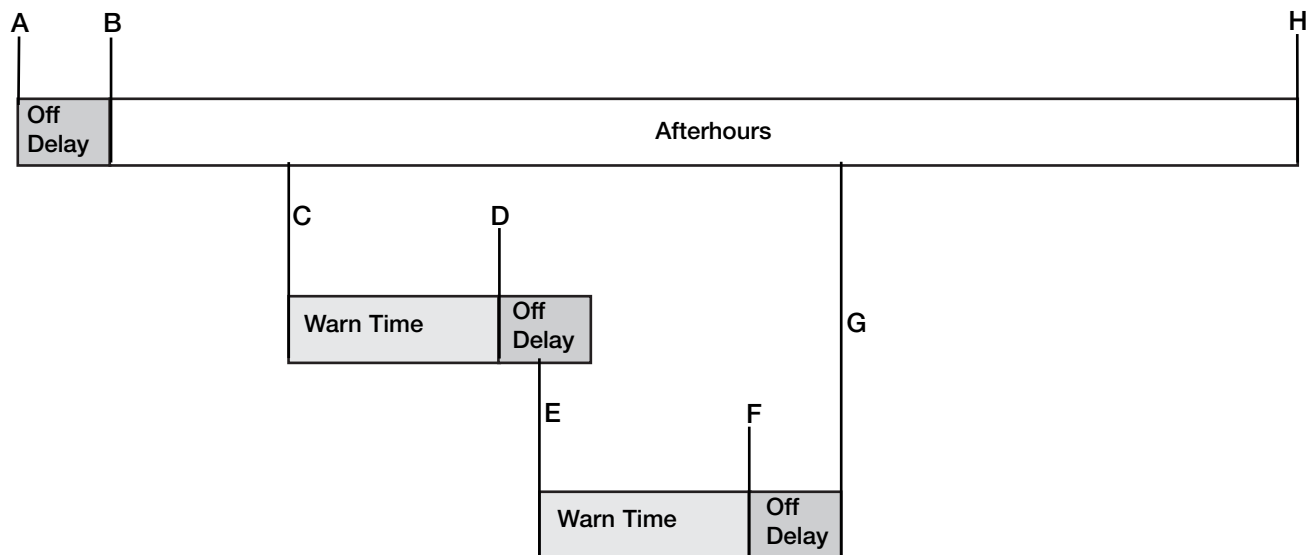



STEP 5 (continued)

Adding Weekly Events

Weekly events occur each week on a specific day.

- From the **Main Menu** use and to highlight **Time Clock Setup** and press or (OK).
- Use and to highlight **Add Event** and press or (OK).
- Use and to highlight **Add Weekly Event** and press or (OK).
- Use and to select the **Day** to which you would like to add the event and press or (Next).
- Use and to select **Fixed Time** or at a time relative to **Sunset** or **Sunrise**. Press to adjust the time or offset. Adjust the time using and and press or (Next).
- Use and to select the desired **Action** for the event: **Scene**, **Custom Scene**, **Enable or Disable Controls**, **Afterhours Start**, or **Afterhours End** and press or (Next). Refer to the beginning of STEP 5 for an explanation of the various action types.

Note: For *Afterhours End*, this step is complete.

B. **Time Clock Setup**

Setup Clock	
Add Event	
Copy Events	
View / Modify Events	
Back	OK

C. **Add Event**

Add Weekly Event	
Add Holiday Event	
Back	OK

D. **Add Weekly Event**

Select Day: Sunday	
Cancel	Next

E. **Event Time**

Type	Time
Fixed	08:00 AM
Previous	Next

Event Time

Type	Time
Sunrise	+ 00:15
	HH : MM
Previous	Next



STEP 5 (continued)

Adding Weekly Events (continued)

If Selecting a Scene Action

- G. In step F, if you selected **Scene**, use and to select the desired scene and press or (Done). To add another event to this same schedule, select **Yes** when prompted “Modify More Events?”

G. **Select Scene**

Scene:

Previous **Done**

If Adding a Custom Scene Action

- G. In step F, if you selected **Custom Scene**, set the circuit settings for the custom scene. Then press or (Done). To add another event to this same schedule, select **Yes** when prompted “Modify More Events?”

Note: Modified scenes will reflect changes in real time.

G. **Select Circuits**

All Circuits	-	---
001 Dim	-	10%
002 Dim	-	20%
003 Relay	-	ON

Previous **Done**

If Selecting an Afterhours Start Action

- G. In step F, if you selected **After Hours Start**, choose **Select Scene** or **Set Circuit Level**. Then press or (Next).
- H. Select the scene or set the circuit levels to be used for afterhours mode. Then press or (Done). Refer to the beginning of STEP 5 for a detailed description of how afterhours mode works.

Note: Modified circuit levels will reflect changes in real time.

To add another event to this same schedule, select **Yes** when prompted “Modify More Events?”

Note: You will set the afterhours warn time, flash count, and off delay later in STEP 5.

G. **Afterhours Setup**

Select Scene

Set Circuit Levels

Previous **Next**



STEP 5 (continued)

Adding Holiday Events

Holiday events occur on a specific date and can last for 1 to 90 days.

- From the **Main Menu** use and to highlight **Time Clock Setup** and press or (OK).
- Use and to highlight **Add Event** and press or (OK).
- Use and to highlight **Add Holiday Event** and press or (OK).
- Use and to select the holiday to which you would like to add the event and press or (Next).

To define a new holiday, select **New Holiday**.

- Enter the start date of the holiday.
- Enter the duration of the holiday. For example, New Year's might be defined as starting on December 31 and lasting 2 days (December 31 and January 1).

- Use and to select **Fixed Time** or at a time relative to **Sunset** or **Sunrise**. Press to adjust the time or offset. Adjust the time using and and press or (Next).
- Use and to select the desired **Action** for the event: **Scene, Custom Scene, Enable or Disable Controls, Afterhours Start, or Afterhours End** and press or (Next). Refer to the beginning of STEP 5 for an explanation of the various action types.

Program the action using the same method as for a weekly event. Refer to "Adding Weekly Events" earlier in STEP 5.

Note: For *Afterhours End*, this step is complete.

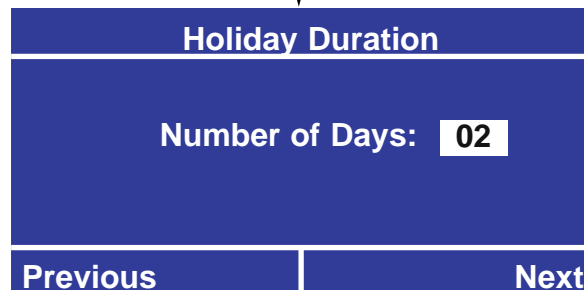
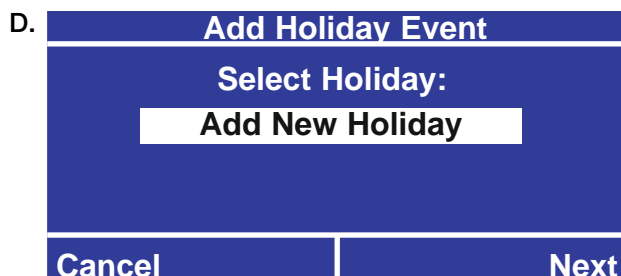



STEP 5 (continued)

Copying Events

- From the **Main Menu** use and to highlight **Time Clock Setup** and press or (OK).
- Use and to highlight **Copy Events** and press or (OK).
- Use and to highlight **Copy Weekly Event** or **Copy Holiday Event** and press or (OK).
- Use and to select the day of the week or holiday you would like to copy from and press or (Next).
- Use and to select the event you would like to copy and press or (Next). If you would like to copy all events programmed for this day or holiday, select **All Events**.
- Use and to select the day or holiday you would like to paste to and press or (Done). Holidays appear after the weekdays in the list. To add a new holiday, select **New Holiday** at the end of the list and then modify the existing holiday's information to save it as a new holiday
To paste the event to another day or holiday, select **Yes** when prompted to "Paste Again?".

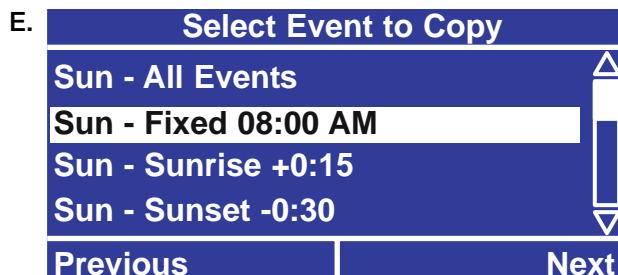

Deleting Events

- From the **Main Menu** use and to highlight **Time Clock Setup** and press .
- Use and to highlight **Delete Event**.
- Use and to highlight **Delete Weekly Event** or **Delete Holiday Event**.
- Use and to select the day of the week or holiday you would like to delete from.
- Use and to select the event you would like to delete. If you would like to delete all events for that schedule, select **All Events**.
- You are asked to confirm deleting the event(s). Press **Yes** to delete, otherwise press **No**.
To delete another event from that day or holiday, select **Yes** when prompted to "Delete Another?".

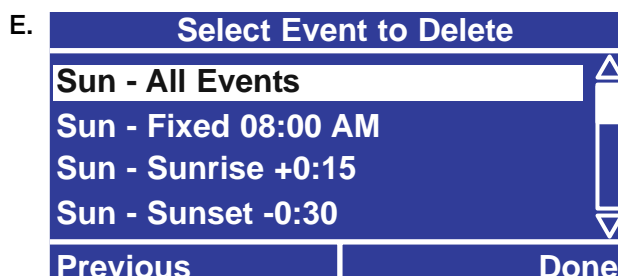
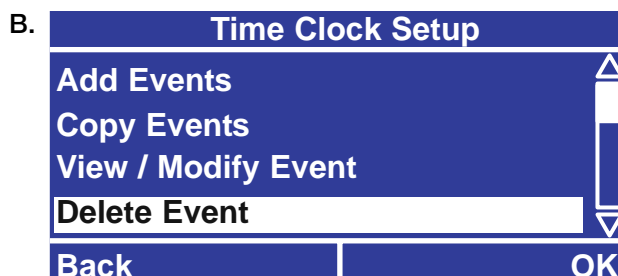



STEP 5 (continued)

Viewing / Modifying Events

- From the **Main Menu** use ▲ and ▼ to highlight **Time Clock Setup** and press ⏎ or Ⓜ (OK).
- Use ▲ and ▼ to highlight **View/Modify Event** and press ⏎ or Ⓜ (OK).
- Use ▲ and ▼ to highlight **Modify Weekly Event** or **Modify Holiday Event** and press ⏎ or Ⓜ (OK).
- Use ▲ and ▼ to select the day or holiday you would like to view or modify and press ⏎ or Ⓜ (Next).
- Use ▲ and ▼ to select the event you would like to view or modify and press ⏎ or Ⓜ (Next).
- You now have the opportunity to modify this event. For procedures, refer to “Adding Weekly Events” or “Adding Holiday Events” earlier in STEP 5.

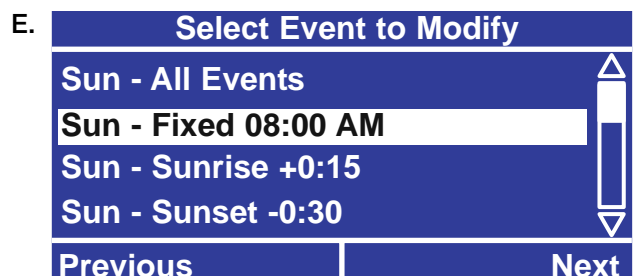
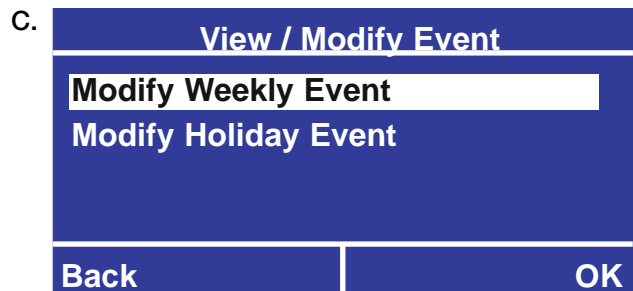
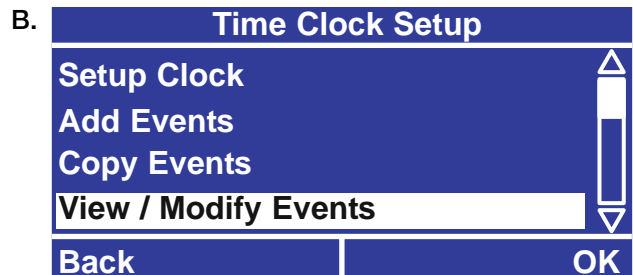

Afterhours Setup

- From the **Main Menu** use ▲ and ▼ to highlight **Panel Setup** and press ⏎ or Ⓜ (OK).
- Use ▲ and ▼ to highlight **Afterhours Setup** and press ⏎ or Ⓜ (OK).
- Use ▲ and ▼ to set a **Warn Time**, from 1 to 180 minutes and press ⏎ or Ⓜ (Next).
- Use ▲ and ▼ to set the **Flash Count**, from 1 to 15 flashes and press ⏎ or Ⓜ (Next).
- Use ▲ and ▼ to set an **Off Delay**, from 1 to 180 minutes and press ⏎ or Ⓜ (Done).

Notes:

To add an afterhours start action, refer to “Adding Weekly Events” earlier in STEP 5.

120 minutes is the maximum allowable off delay in California Title 24.

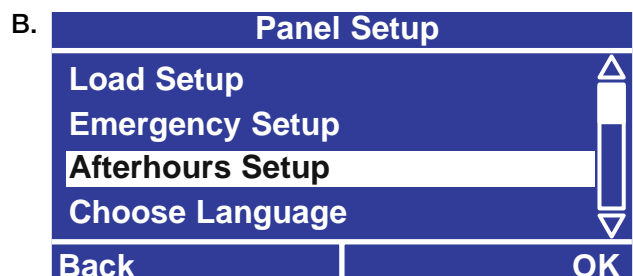
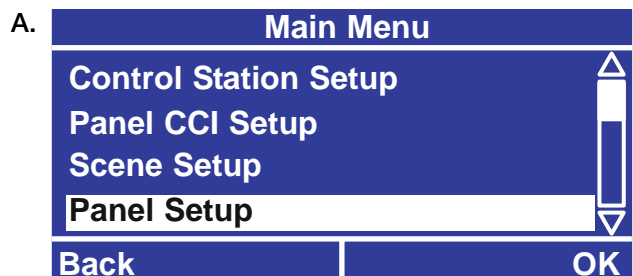



STEP 6

Panel Contact Closure Inputs

The *LCP128* controller has two contact closure inputs (see illustration below). Separate actions can be defined for the opening and closing of the contact. The choices are:

- **Scene or Custom Scene** - Each time the contact closure input is activated, the assigned circuits go to the programmed scene. A scene can also be used to control contact closure outputs.
- **Enable or Disable Time Clock** - Enable or disable the function of the time clock.
- **Toggle** - Each time the contact closure input is activated, the assigned circuits toggle between on and off. If the assigned circuits are in a mixed state (some on and some off), the circuits turn on.
- **Delay To Off** - Each time the contact closure input is activated, the assigned circuit(s) turn off after the preset amount of time (1 - 90 minutes).

Before proceeding with STEP 6, complete the Control Station Table located at the back of this guide. Record how each local contact closure should function. Designate them: Panel 1 CCI 1 Opening, Panel 1 CCI 1 Closing, Panel 1 CCI 2 Opening, Panel 1 CCI 2 Closing, and continue for Panel 2 through Panel 8 as required.

Panel CCI Terminal Markings

- 1: 15 V \equiv or 24 V \equiv CCI 1
- 2: Common CCI 1
- 3: 15 V \equiv or 24 V \equiv CCI 2
- 4: Common CCI 2

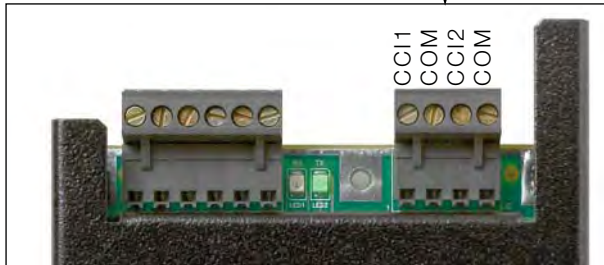

LCP128 controller Top



STEP 6 (continued)

Configure Panel Contact Closure Inputs

Note: For contact closure inputs wired to a Lutron OMX-AV control station, refer to STEP 4.

- A. From the **Main Menu** use and to highlight **Panel CCI Setup** and press or (OK).
- B. Use and to choose the contact closure input you want to configure and press or (OK).
- C. Use and to select whether you want to define an action for when the contact **Opens** or **Closes** and press or (Next).
- D. Use and to choose the type of **Action** for the CCI: **Scene**, **Custom Scene**, **Enable or Disable Time Clock**, **Enable or Disable Controls**, **Delay to Off**, **Toggle**, or **No Action**.

Program the desired action using the following procedures.

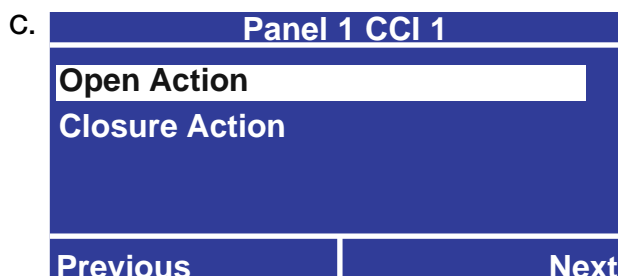
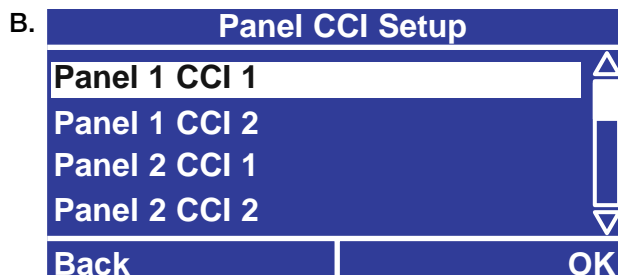

If Selecting a Toggle Action

- E. In step D, if you selected **Toggle**, the Assign Circuits screen lists all the circuits. Unassigned circuits are presented as numbers with hash lines going through them. Move the cursor to a circuit number and press to toggle between **Assigned** and **Unassigned** (dashed). All circuits can be toggled by selecting **ALL Circuits** and pressing . When the circuits are programmed press .
- F. For dimming circuits affected by the action, use and to set the **Fade Time**.
- G. For a combination of dimming and switching circuits, use and to set when the switches react (**Start of Fade** or **End of Fade**). Then press or .

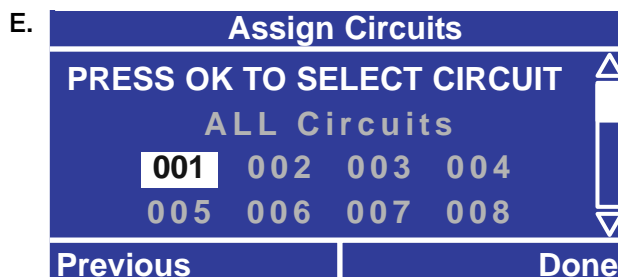



STEP 6 (continued)

Configure Contact Closure Inputs (continued)

If Selecting a Scene Action

- E. In step D, if you selected **Scene**, use ▲ and ▼ to select the scene and press ⏎ or ⌘ (Done).

E. **Select Scene**

Scene:

Previous Done

If Selecting a Custom Scene Action

- E. In step D, if you selected **Custom Scene**, the Select Circuits screen lists all the circuits. Use ▲ and ▼ to select a circuit and ◀ and ▶ to change the setting for that circuit. Or to simultaneously change all circuits, select **All Circuits** and use ◀ and ▶ to change the setting.

Note: The **All Circuits** function enables you to simultaneously adjust the percentage for all dimming circuits or to turn all circuits off or on.

Circuit settings depend on the circuit type:

Switching: ON, OFF, --- (unaffected)

Dimming: OFF, 1 - 100%, --- (unaffected)

Motors: Raise, Lower, Stop, Jog Up, Jog Down

Fans: Low, Medium, Medium-High, High

Note: The --- (unaffected) setting means the circuit is not affected by this scene.

When the circuits are programmed for this custom scene press ⏎ or ⌘ (Next).

- F. The Select CCO Address screen is displayed only if control station devices with contact closure outputs (OMX-AV or OMX-CCO-8) have been entered into the system.

Use ▲ and ▼ to select the output to be associated with the scene being programmed. Use ◀ and ▶ to change the setting for that output: **maintained open**, **maintained close**, **momentary pulse**, or --- (unaffected). When the outputs are programmed for this custom scene, press ⏎ or ⌘ (Done).

- G. For dimming circuits affected by the custom scene, use ▲ and ▼ to set the **Fade Time** and press ⏎ or ⌘.

- H. For a combination of dimming and switching circuits, use ▲ and ▼ to set when the switches react (**Start of Fade** or **End of Fade**). Then press ⏎ or ⌘.

E. **Select Circuits**

All Circuits	- ---
001 Dim	- 10%
002 Dim	- 20%
003 Relay	- ON

Previous Next

F. **Select CCO Address**

A01 CCO1	- Maintained Open
A01 CCO2	- ---
A01 CCO3	- ---
A01 CCO4	- ---

Previous Done

Address number Contact closure output number

G. **Custom Scene Fade Time**

Fade Time:

Previous Next

H. **Custom Scene Fade Time**

When do switches react?

Previous Done



STEP 6 (continued)

Configure Contact Closure Inputs (continued)

If Selecting a Delay to Off Action

- E. In step D, if you selected **Delay to Off**, use and to set the **Time to Off** and press or (Next).
- F. The Assign Circuits screen lists all the circuits. Unassigned circuits are presented as numbers with hash lines going through them. Move the cursor to a circuit number and press to toggle between **Assigned** and **Unassigned** (dashed). All circuits can be toggled by selecting **ALL Circuits** and pressing . When the circuits are programmed press .
- G. For dimming circuits affected by the action, use and to set the **Fade Time** and press or .
- H. For a combination of dimming and switching circuits, use and to set when the switches react (**Start of Fade** or **End of Fade**). Then press or .

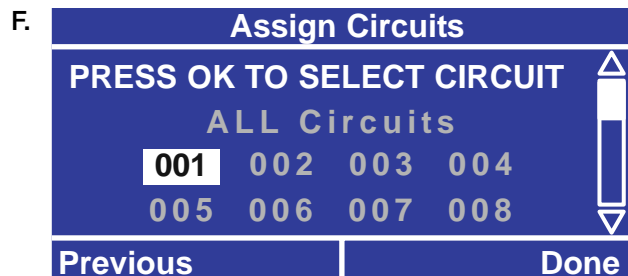
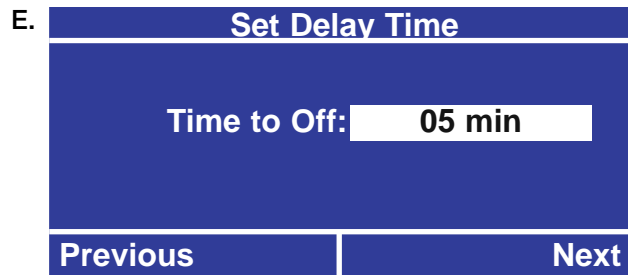



STEP 7

Emergency Power Mode

Perform this step only if you want to configure an emergency power mode when normal power is lost. All control station inputs and time clock events are ignored while in emergency power mode. This step defines if the panel has emergency circuits and, if so, how to configure the emergency settings. For multi-panel systems, emergency settings are configured on the master panel and each remote panel.

- Identify panels fed by normal (non-essential) power. Move their **emergency switches** to the left position, see illustration below.
- For all the emergency (essential) lighting panels, move the **emergency switches** to the right position, see illustration below.
- The essential and non-essential panels must be connected by a sense line wired to **terminal 5** on the link connector on the LCP128 controller, see illustration below. (For wiring details see page 56).

In this configuration, the emergency (essential) lighting panel will “sense” the normal panels’ power. When normal power is lost, the emergency panel will go to the emergency settings (factory set to all circuits On).

Panels with their switch in the center (unaffected) position will not affect or react to the sense line.

Notes:

- *If UL 924 certification is required, the Lutron Emergency Lighting Interface (LUT-ELI-3PH) may be used to meet code. The LUT-ELI-3PH senses the normal (non-essential) line voltage on all three phases (3PH) of normal power. When one or more phases of power are lost, the LUT-ELI-3PH will send a signal to **terminal 5** on the LCP128 controller(s). When the **emergency switch** is set to the right position (essential), the emergency lighting settings will be recalled. The LUT-ELI-3PH can be used with one or multiple panel systems.*
- *Loss of normal power can be simulated by turning off all connected normal (non-essential) panels’ control breaker.*
- *When the emergency switch is in its center position (as shipped), terminal 5 on the panel does not respond to the emergency.*

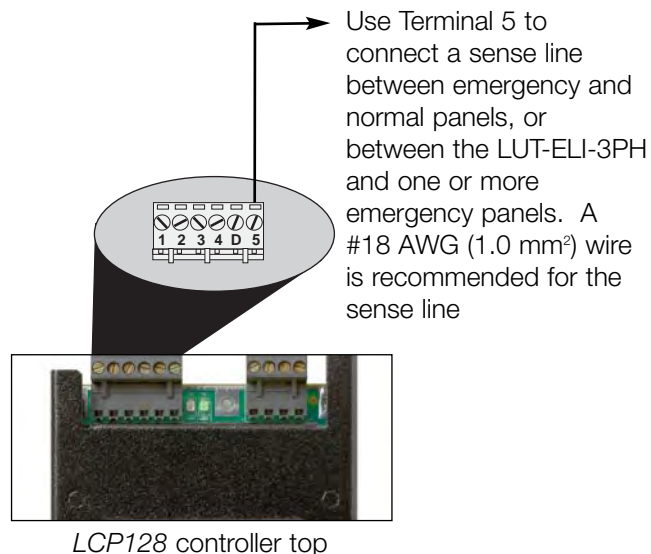

Three-position **Emergency Switch** is located at the bottom of the LCP128 controller.

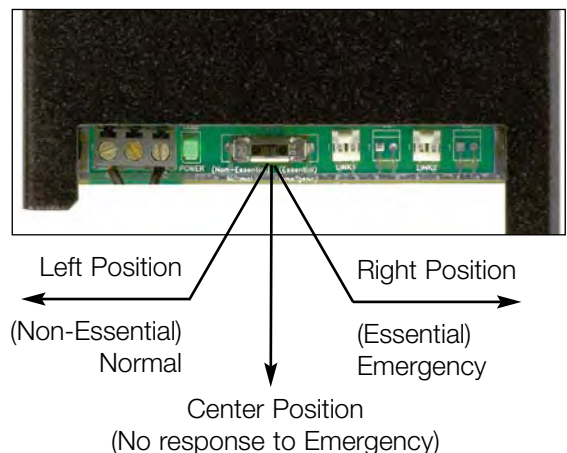



STEP 7 (continued)

Configuring the Emergency Setting Levels

- From the **Main Menu** use and to highlight **Panel Setup** and press or (OK).
- Use and to highlight **Emergency Setup** and press or (OK).
- When asked if the panel has emergency functionality, use and to select **Yes** and press or (Next).
- The Emergency Setup screen lists all the circuits and their default emergency settings. Use and to select a circuit and and to change the setting for that circuit. To simultaneously change all circuits, select **All Circuits** and use and to change the setting.

Note: The **All Circuits** function enables you to simultaneously adjust the percentage for all dimming circuits or to turn all circuits off and on.

Circuit settings depend on the circuit type:

Switching: ON, OFF, --- (unaffected)

Dimming: OFF, 1 - 100%, --- (unaffected)

Motors: Open, Close, Stop, Jog Up, Jog Down

Fans: Low, Medium, Medium-High, High

Note: The --- (**unaffected**) setting means the circuit is not affected by emergency mode.

When the circuits are programmed for emergency mode, press or (Next).

- The Select CCO Address screen is displayed only if control station devices with contact closure outputs (OMX-AV or OMX-CCO-8) have been entered into the system. Use and to scroll through the list to select the output to be associated with the button being programmed. Use and to change the setting for that output between: **maintained open**, **momentary open**, **momentary close**, **maintained close** or --- (unaffected). When the outputs are programmed press or (Done) to update the database.
- For multi-panel systems, repeat the procedure to program the emergency settings at each remote panel.

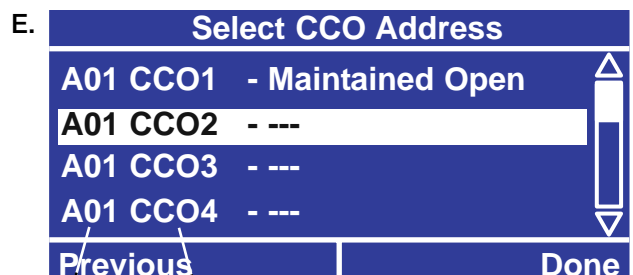
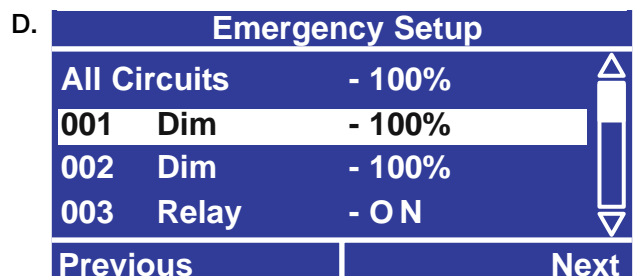
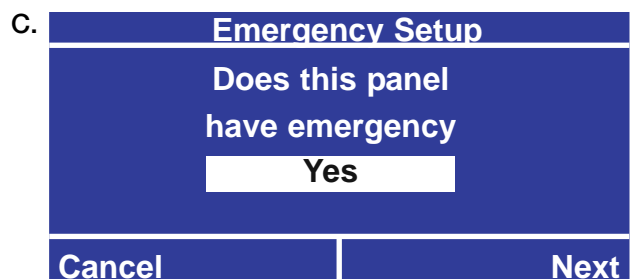
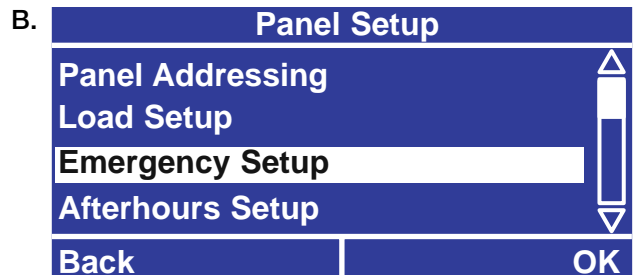

Address number Contact closure output number



STEP 7 (continued)

Panel-to-Panel Wiring for Emergency Systems

To provide emergency lighting to a multi-panel system, wire as shown. Note that the Normal (non-essential) panels are fed from a normal utility power source, and the Normal/Emergency (essential) panels are fed from a normal power source that is switched to an emergency power source via an automatic transfer switch. Lutron power panels can not be fed from both normal and emergency power sources at the same time. Safety codes call for a physical separation between these power sources that is not provided in the power panels. The separation is typically provided in the UL1008 transfer switch.

Circuits in the normal panel and the emergency panel must be on the same control link; both the zone intensity and on/off information will be provided to both panels when normal power is present. All dimmers will go to the level set at the control. All load wires will go directly from the power panels (normal or emergency) to the loads. The #5 (Sense) terminal on the controller is a sense line for the emergency panel. In the normal panel this terminal #5 outputs a sense voltage indicating that normal power is present. When normal power is lost TO ALL NORMAL PANELS, the sense voltage is lost. If power is lost to only one normal panel (as shown below), the emergency panels will NOT come on. Provided the emergency power source has been switched to feed the emergency panel, all emergency circuits will be turned on to full intensity and the controls will be disabled. Also, if the sense line is opened between the group of normal panels and the group of emergency panels, the emergency panel will respond by sending its loads to full intensity.

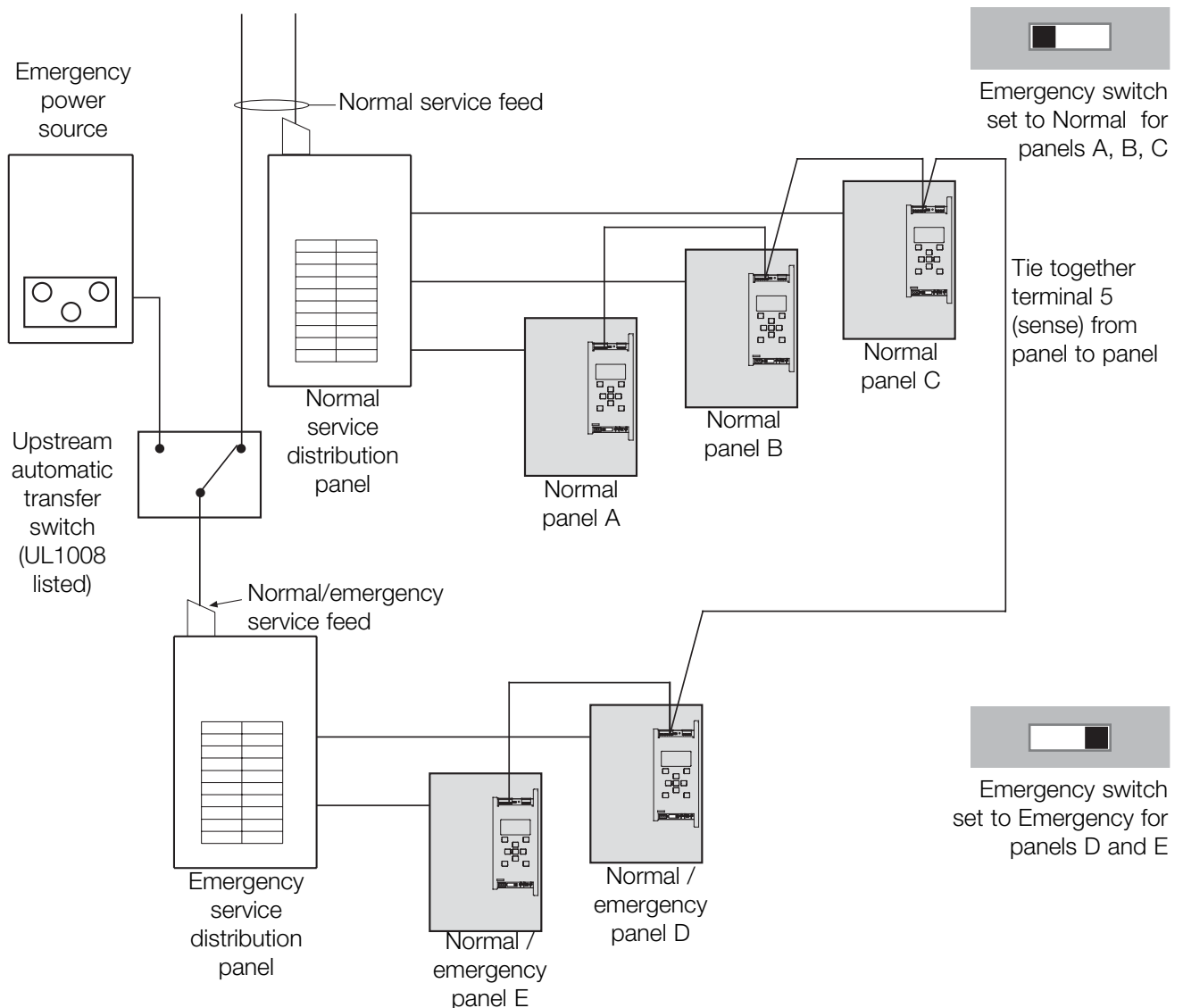



Overrides

Overview

From time to time, you may need to temporarily override the programmed settings for your system (for example, to raise or lower the lights in a single circuit).

The *LCP128* controller enables you to perform the following types of overrides:

- **Circuit Level Override** - Directly set a level for a dimming circuit or turn any circuit on or off. The override occurs immediately and remains in effect as long as the **Set Circuit Levels** screen is displayed on the controller LCD. Pressing **Done** to exit the **Set Circuit Levels** screen keeps the circuits at the override setting until they are changed by a control station input or time clock event. Pressing **Cancel** to exit the **Set Circuit Levels** screen returns the lights to their previous state.
- **Scene Override** - Directly apply circuit settings using a different scene. The override occurs immediately and remains in effect as long as the **Select Scene** screen is displayed on the controller. Pressing **Done** to exit the **Select Scene** screen keeps the circuits at the override setting until they are changed by a control station input or time clock event. Pressing **Cancel** to exit the **Select Scene** screen returns the lights to their previous state.
- **Time Clock Override** - Enable or disable all time clock events. When the time clock is re-enabled, missed events do not occur; control starts with the next scheduled event.
- **Control Station Override** - Enable or disable all control stations. When control stations are re-enabled, button presses, key turns, and contact closures are processed again.
- **Afterhours Override** - Ends afterhours mode until it is re-started by the time clock.

Note: All override options are available from the master panel. Circuit level overrides are also available from remote panels.



Overrides (continued)

Override the Circuits by Setting Circuit Levels

- A. From the **Main Menu** use and to highlight **Overrides** and press or (OK).

Note: From a remote panel, choose **Set Circuit Levels** from the **Main Menu**.

- B. Use and to choose **Set Circuit Levels** and press or (OK)
- C. The circuits are listed with their current settings displayed. Use and to select a circuit and and to change the setting for that circuit. To change all circuits, select **All Circuits** and use and to change the setting.

Note: The **All Circuits** function enables you to adjust the percentage for all dimming circuits or to turn all circuits off and on.

Circuit settings depend on the circuit type:

Switching: ON, OFF, Flash

Dimming: OFF, 1 - 100%, Flash

Motors: Open, Close, Stop, Jog Up, Jog Down

Fans: Low, Medium, Medium-High, High

Note: The **Flash** setting cycles a circuit between On and Off once every few seconds - useful for locating a circuit in the space.

Changes take effect immediately. As long as the Set Circuit Levels screen is displayed, the circuits will remain at the set state. The settings override all other inputs (time clock events, button presses, contact closure inputs, etc.).

The override Set Circuit Levels screen will not time-out to the Home screen or screen saver.

- D. **To exit the Set Circuit Levels screen and keep the changed settings**, press or (Done). The circuits will remain at the override setting until they are changed by a control station input or time clock event.

To exit the Set Circuit Levels screen and return the circuits to what they were before setting overrides, press (Cancel).

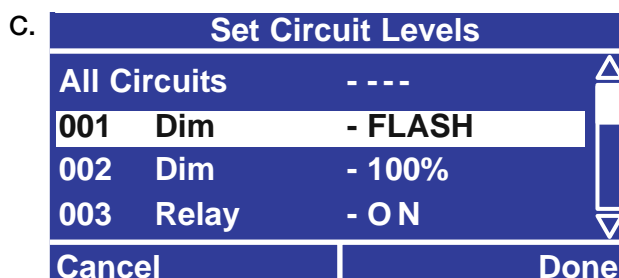
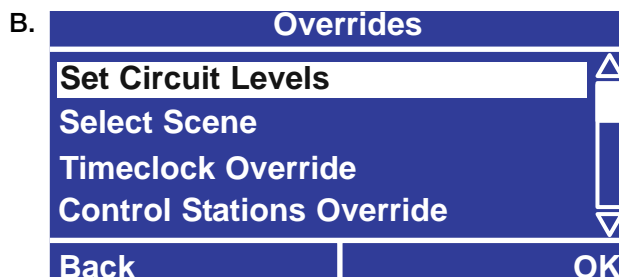
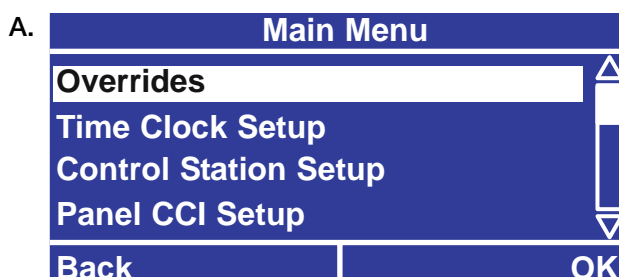



Overrides (continued)

Override Circuits Using a Scene

- A. From the **Main Menu** use ▲ and ▼ to highlight **Overrides** and press ⏎ or ⌘ (OK).
- B. Use ▲ and ▼ to choose **Select Scene** and press ⏎ or ⌘ (OK)
- C. Use ▲ and ▼ to choose the **Scene** and press ⏎ or ⌘ (Done).

Changes take effect immediately. As long as the Select Scene screen is displayed, the circuits will stay at the selected scene. This setting overrides all other inputs (time clock events, button presses, contact closure inputs, and so on).

The override Select Scene screen will not time-out to the Home screen or screen saver.

- D. **To exit the Select Scene screen and keep the scene settings**, press ⏎ or ⌘ (Done). The circuits will remain at the override setting until they are changed by a control station input or time clock event.
To exit the Select Scene screen and return the circuits to what they were before setting overrides, press * (Cancel).

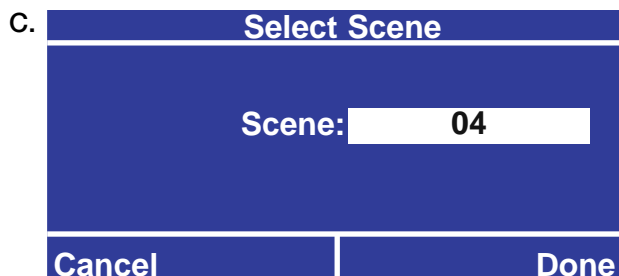
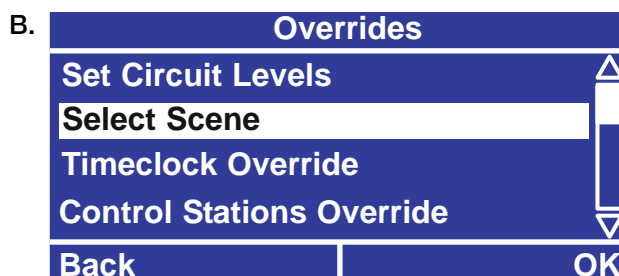
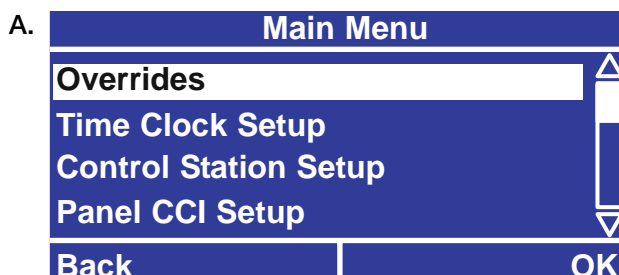



Overrides (continued)

Disable or Enable all Time Clock Events

- From the **Main Menu** use and to highlight **Overrides** and press or (OK).
- Use and to highlight **Time Clock Override** and press or (OK).
- Use and to change the setting to **Disabled** or **Enabled** and press or (Done).

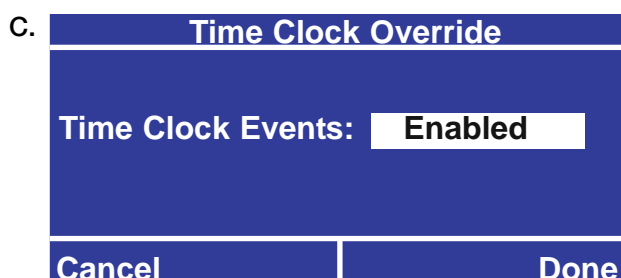
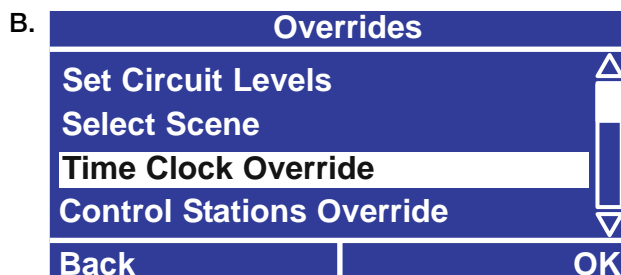

Disable or Enable all Control Stations

- From the **Main Menu** use and to highlight **Overrides** and press or (OK).
- Use and to highlight **Control Stations Override** and press or (OK).
- Use and to change the setting to **Disabled** or **Enable** and press or (Done).

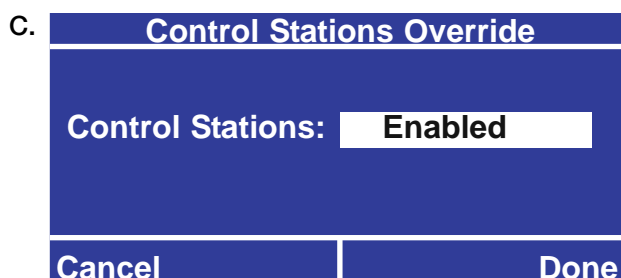
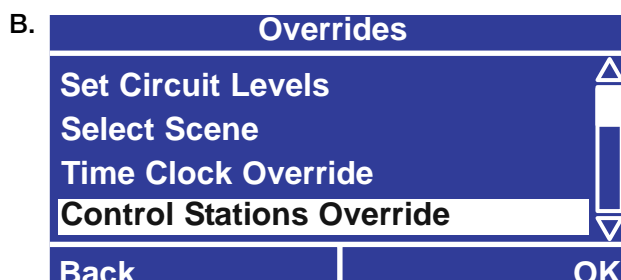

To End Afterhours Mode

- From the **Main Menu** use and to highlight **Overrides** and press or (OK).
- Use and to highlight **Afterhours Override** and press or (OK).
- The screen title indicates whether afterhours mode is enabled or disabled. To end afterhours mode press for **Yes**. (Or press for **No**.)

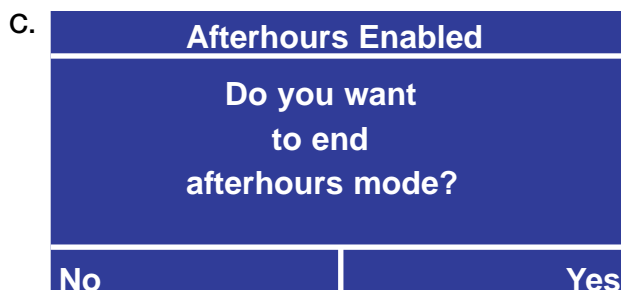



Locking and Unlocking the Controller

Overview

The *LCP128* controller may be password protected to prevent unauthorized access to system settings. If no controller buttons are pressed during a user-set time (1-90 minutes), the controller locks automatically. A 4-digit password must be set when locking is configured. This password must be entered before any of the menus can be accessed when the controller is locked. This password must also be entered to change the lockout settings.

Setting the Controller to Lock

- From the **Main Menu** use and to highlight **Panel Setup** and press or (OK).
- Use and to highlight **Password Protection** and press or (OK).
- Use and to select either **Change Password** or **Set Lockout Time** and press or (OK).
- If **Set Lockout Time** is selected, use and to set the time of inactivity (no button presses on the controller) to wait before locking and press or (Next). If you do not want the controller to lock, select **Do Not Lock**.
- If **Change Password** is selected, enter the password you would like to set (default is 0 0 0 0). Use and to select the digit to change, and then and to change each value. When you have entered the password press or (Next). Then re-enter the new password for confirmation and press or (Done)

The controller will now lock after the set amount of time.

Note: If you forget the password, contact Lutron Technical Support at (800) 523-9466 to unlock the controller.

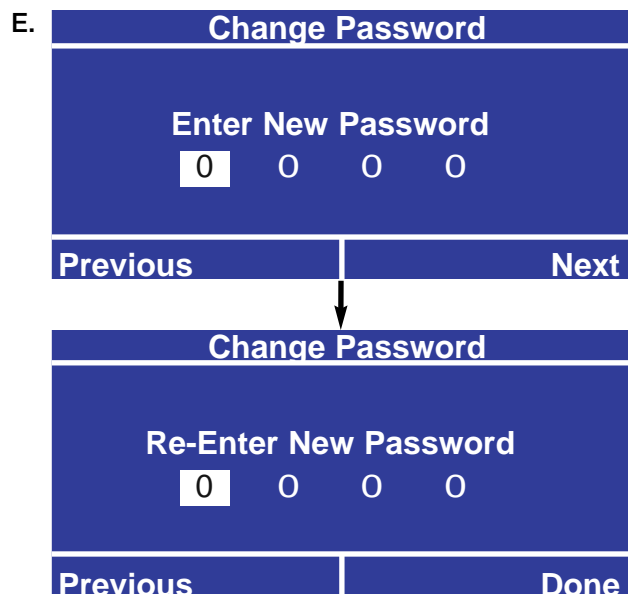
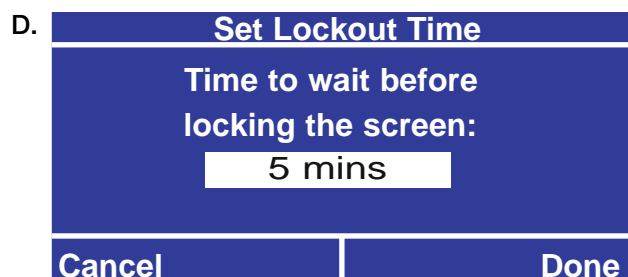
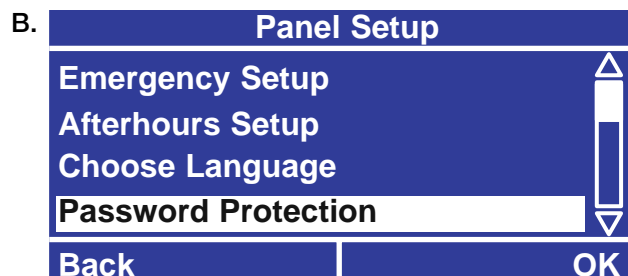









Locking and Unlocking the Controller (continued)

Unlocking the Controller

If the controller is locked, a LOCKED message is displayed on the Home screen. You need to unlock the controller before you can access the Main Menu.

- A. Press  (Unlock).
- B. To enter the password, use  and  to select the digit to change, and then  and  to change each value. When you have entered the password, press  or  (OK).

Note: If you forget the password, contact Lutron Technical Support at (800) 523-9466 to unlock the controller.

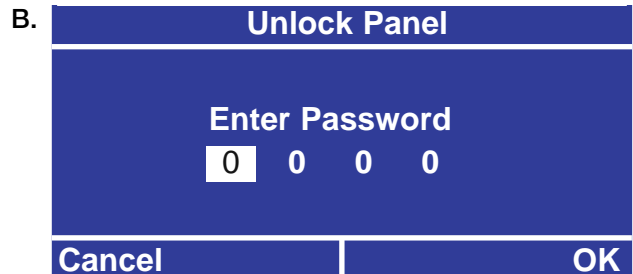
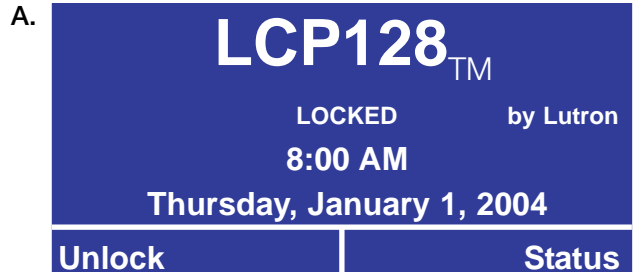



Troubleshooting Guide



Symptom	Likely Cause	Action(s) for Remedy
Circuits always ON or always OFF.	(a) Bypass jumpers have not been removed.	(a) Visually inspect the terminal blocks. If the metal bypass jumpers are installed, see the appropriate panel installation guide for proper circuit test and jumper removal procedure.
	(b) Controller is not powered.	(b) The 'POWER' LED at the bottom of the controller should be lit (refer to "Controller Overview" at the beginning of this guide for LED location). If it is not, there is no power, and the feed should be checked.
	(c) Controller is in the override screen.	(c) Press the  Home button to exit the override screen.
	(d) Emergency is active.	(d) Disable the emergency function by sliding the emergency switch at the bottom of the controller to the center position on all panels.
	(e) Circuit breaker is OFF.	(e) Turn the breaker on to verify proper power supply to each circuit. The breaker could be in the <i>LCP128</i> panel or in a separate distribution panel if the <i>LCP128</i> is a feed-through panel.
	(f) Duplicate panel addresses.	(f) Check that all panel addresses are unique. The panel address is listed on the Home screen. To change addresses, see STEP 1 in this guide for more information.
Circuit breakers are tripping.	(a) Circuits are overloaded.	(a) Check load continuity (between DH and N) with a meter, and verify that there is not a short. If shorted, repair the miswire or load failure. If not shorted, reset the breaker and measure the current on the circuit. If greater than 16 A, the circuit is overloaded and should be remedied by re-lamping to smaller loads or by "splitting" the circuit between two dimming circuits.



Troubleshooting Guide (continued)



Symptom	Likely Cause	Action(s) for Remedy
Control station buttons do not work.	(a) Link has a panel or control address conflict.	(a) Check all control station addresses, and ensure that there are no duplicate settings. See the appropriate panel installation guide for more information.
Control station LED's are flashing.	(b) Control station is addressed incorrectly.	(b) Check that the address of the non-working control station is correct and unique. See the appropriate panel installation guide for more information.
Control station buttons or CCI's work sporadically.	(c) Button is not programmed.	(c) Program the button's function at the controller. See STEP 3 in this guide for more information.
Control station LED's do not turn on.	(d) Control stations are disabled.	(d) Enable the control stations using the controller. See the "Overrides" section in this guide for more information.
	(e) Control station link is mis-wired.	(e) See the appropriate panel installation guide for proper wiring. If a T-tap was created to wire a control to the control station link, it should be no longer than 8 ft. (2.44m).
	(f) Emergency is active.	(f) Disable the emergency function by sliding the emergency switch at the bottom of the controller to the center position on all panels.
Control station does not perform defaults.	(g) At least one control station is programmed.	(g) Set all control stations to "NO STATION".
Panel contact closure inputs do not work.	(a) Input closure/opening is not occurring.	(a) Check that the device controlling the input is opening or closing properly.
	(b) Input is programmed incorrectly.	(b) Program the contact closure input function on the controller. See STEP 4 in this guide for more information. Note that open and closure actions can be programmed to conflict with each other, and this may cause undesirable results.
	(c) Input is mis-wired.	(c) See the appropriate panel installation guide for proper wiring.



Troubleshooting Guide (continued)



Symptom	Likely Cause	Action(s) for Remedy
Time clock events do not occur.	(a) Controller is in the override screen.	(a) Press the  Home button to exit the override screen.
Sunrise or sunset events do not occur at the correct time.	(b) Timeclock is disabled.	(b) Enable the timeclock. See the “Overrides” section in this guide for more information.
	(c) Time is not set.	(c) Set the time. See STEP 5 in this guide for more information.
	(d) Date is not set correctly.	(d) Set the date. See STEP 5 in this guide for more information.
	(e) Location is not set correctly.	(e) Set the location. See STEP 5 in this guide for more information.
	(f) Holiday schedule is in effect.	(f) Check if there is a holiday on the date the event is not occurring. See STEP 5 in this guide for more information.
	Circuits are flashing erratically.	(a) Duplicate panel addresses.
(b) Duplicate control station addresses.		(b) Check that the address of each control station is correct and unique. See the appropriate panel installation guide for more information.
(c) Contact closure input is controlling the circuits.		(c) Confirm that the contact closure input into the system is in a steady state. Verify this at every panel contact closure input and at every OMX-AV.
(d) Control station link is mis-wired.		(d) See the appropriate panel installation guide for proper wiring. If a T-tap was created to wire a control to the control station link, it should be no longer than 8 ft. (2.44 m).
(e) Timeclock events are occurring.		(e) Check the timeclock events for the day or holiday that coincide with the time of the erratic behavior. Holiday schedules override the 7 daily schedules. See STEP 5 in this guide for more information.
(f) Afterhours mode is active.		(f) Afterhours mode may cause the lights to flash. See STEP 5 in this guide for more information.
Circuit levels don't maintain values set through override screen.		(g) DMX is active.



Troubleshooting Guide (continued)



Symptom	Likely Cause	Action(s) for Remedy
Contact closure outputs do not work.	(a) Controller is in the override screen.	(a) Press the  Home button to exit the override screen
	(b) Control Stations are disabled.	(b) Enable the controls. See the "Overrides" section in this guide for more information.
	(c) Link has an address conflict.	(c) Check all control station address switches and ensure that there are no duplicate settings.
	(d) Link is mis-wired.	(d) See the appropriate panel installation guide for proper wiring. If a T-tap was created to wire a control to the control station link, it should be no longer than 8 ft. (2.44 m).
	(e) System is programmed incorrectly.	(e) Check the action that initiates the output, and ensure that it is programmed correctly. See STEP 4 in this guide for more information.
Emergency does not work.	(a) Sense lines are not connected.	(a) For emergency to work, the right-most pin on the 6-pin connector at the top of the controller must be wired between panels. See the appropriate panel installation guide for more emergency sense wiring information.
	(b) Emergency switch is not set correctly.	(b) Essential emergency panels must have their emergency switch set to the right-most position. Non-Essential normal panels must have their emergency switch set to the left-most position.
	(c) There must be at least one non-essential panel and at least one essential panel.	(c) Essential emergency panels sense the presence of non-essential panels. Therefore, there must be at least one of each for emergency to work.
	(d) Emergency levels are not programmed.	(d) Emergency levels must be programmed. See STEP 7 in this guide for more information.
LCD backlight is OFF.	(a) Screen saver is on.	(a) Press any button on the controller.
	(b) Controller is not powered.	(b) The 'POWER' LED at the bottom of the controller should be lit. If it is not, there is no power, and the circuit should be checked for power.



Troubleshooting Guide (continued)



Symptom	Likely Cause	Action(s) for Remedy
RS232 commands do not work.	(a) Baud rate is wrong. (b) See 'Control station buttons do not work' Symptom of this troubleshooting section.	(a) Check that the baud rate switches on the OMX-RS232 are correct. The baud rate on the OMX-RS232 must match the baud rate of the sending device.
OMX-CCO-8 is not working.	(a) Option switch on the OMX-CCO-8 is not set correctly. (b) See 'Control station buttons do not work' Symptom of this troubleshooting section.	(a) All Option switches should be in the ON position.
OMX-AV outputs are not working.	(a) DIP switch 8 on OMX-AV is not set correctly. (b) No external power supply on the outputs. (c) See 'Control station buttons do not work' Symptom of this troubleshooting section.	(a) Set DIP switch 8 to ON. This sets the unit to handle maintained or momentary closures. (b) The OMX-AV requires the outputs to be powered by an external power supply (30 V $\overline{=}$) max).
Password is unknown.		(a) Contact Lutron Technical Support to unlock the controller. Lutron contact information may be found at the end of this guide.
ODMX-512/DMX does not control lights.	(a) DMX is not active.	(a) Check the DMX activation mode. Ensure that ODMX and DMX boards are connected (via Link Status) and that the corresponding activation channel is above 50%. Also ensure that the master control on the stageboard is at 100%.



Wallstations and Key Switches

Clean front surface of control with a soft towel moistened with a mild soap solution (non-ammonia based). Clean approximately every six months.



Caution! Do not spray cleaning solution onto control as it may reach internal components.

LCP128™ Panels

1. Clean any dirt from air vent openings with a vacuum and check for any obstructions which may block air flow. Keep 12" (30.5 cm) above and below panels unobstructed.
2. If any extra wiring is brought into the power panel, thoroughly remove all metal chips, wire strands, insulation and other debris before reapplying power.
3. In the unlikely event of damage to dimming or switching equipment, turn off breakers, replace bypass jumpers, and turn on breakers. This will apply full power to lighting fixtures.



Glossary of Terms



- **Addressing** - how the controls on a link identify each other. Control stations are assigned an address between 1 and 32, using addressing switches 1 through 5 on the unit. Refer to the instructions shipped with the control station or the appropriate panel installation guide for further information.
- **Afterhours Mode** - a time clock mode typically used for turning selected lights off at the end of a building's normal business hours. The system first warns occupants that the lights are going to turn off by flashing the lights (flash count), then waits for a period of time (off delay) before automatically turning the lights off. If an occupant wants the lights to remain on (or turn back on), they can press a wallstation button that controls those lights. The lights then remain on for a set amount of time (warn time) and then the process repeats. This process continues until an afterhours end time clock event occurs.
- **Contact Closure Input (CCI)** - an input provided to the system in the form of two contacts completing a circuit (dry contact closure). This input could be from a button or a relay controlled by another system (fire alarm, building management system, etc.)
- **Contact Closure Output (CCO)** - an output provided from the system in the form of two contacts completing a circuit (dry contact closure). This output could be from a OMX-AV, OMX-CCO-8, button, key switch, or time clock event.
- **Control Link** - the daisy-chained link of control stations wired to the LCP128 panel(s).
- **Control Station** - a device located on the control link that provides low-voltage inputs and / or outputs, typically a wallstation, key switch, OMX-CCO-8, OMX-RS232, or OMX-AV.
- **Custom Scene** - a scene assigned to and programmed for a specific time clock event, button press, or contact closure input.
- **Delay to Off** - up to a 90 minute delay programmed for a group of circuits before turning the lights off; can be recalled by pressing a single button.
- **DMX Theater Mode** - this mode turns off the air gap in the circuit, which provides immediate response time from lighting and other theatrical equipment. It does, however, decrease bulb life and eliminate a safety feature the air gap provides.
- **Emergency Mode** - a mode where all inputs to the system are disabled and circuits are dimmed or turned on or off as set in the emergency mode setup. Activated by the loss of power on the emergency sense line.
- **Flash Count** - the number of times the lights will flash to warn an occupant that the lights are going to turn off automatically.
- **Holiday** - a special time clock schedule that is set to start on a specific date and last a set number of days. The schedule for a holiday overrides the weekly schedule that would normally occur on that day.
- **Holiday Event** - a time clock event that is set to occur on a holiday.
- **LCD (Liquid Crystal Display)** - the graphical display built into the LCP128 controller that is used to configure the system.
- **LED (Light Emitting Diode)** - an illuminated indicator to help in diagnosing controller and control station operation.
- **Maintained vs. Momentary** - a CCO from the LCP128 can be programmed to be a pulse (momentary) or constant (maintained) output.
- **NTOMX-KS** - a control station that requires a key. The key switch can be programmed for a clockwise and counter-clockwise turn.
- **ODMX-512** - a control interface device that allows up to 32 DMX-512 inputs from a theatrical console/stageboard.
- **OMX-AV** - a control station that is connected to the control link and provides up to 5 contact closure inputs and 5 contact closure outputs.
- **OMX-CCO-8** - a control station that is connected to the control link and provides up to 8 contact closure outputs.
- **OMX-RS232** - a control interface device that facilitates building management integration through RS232 commands.
- **Open Action vs. Closure Action** - a CCI into the LCP128 can be programmed to respond to the opening or closing of the contact.
- **Scene** - programmed settings for a circuit or group of circuits, creating an effect that can be recalled by pressing a single button, turning a key, etc.
- **Time Clock Event** - an action that is set to occur at a particular time of day or at a time relative to sunrise or sunset (astronomical).
- **Toggle** - an action that switches the assigned circuits between on and off. If the assigned circuits are in a mixed state (some on and some off), the circuits will turn on.
- **Wallstation** - a control station that mounts on a wall, contains one or more buttons, and wires to the control link. The buttons can be used to activate scenes, toggle circuits, etc.
- **Warn Time** - the amount of time a light can be turned on, by a wallstation or CCI, before automatically being turned off in afterhours mode.
- **Weekly Event** - a time clock event that is set to occur on a specific day of the week (Sunday - Saturday).



Panel Tables

How to Use These Tables:

- For each panel, fill in a description for each circuit. Label all spares.
- Cross out the circuits that do not exist.
- Fill in the system circuit numbers. *(continued on next page)*

Panel 1		
Panel Circuit	System Circuit	Description
1		
2		
3		
4		
5		
6		
7		
8		
9		
10		
11		
12		
13		
14		
15		
16		
17		
18		
19		
20		
21		
22		
23		
24		
25		
26		
27		
28		
29		
30		
31		
32		
33		
34		
35		
36		

Panel 2		
Panel Circuit	System Circuit	Description
1		
2		
3		
4		
5		
6		
7		
8		
9		
10		
11		
12		
13		
14		
15		
16		
17		
18		
19		
20		
21		
22		
23		
24		
25		
26		
27		
28		
29		
30		
31		
32		
33		
34		
35		
36		



Panel Tables

How to Use These Tables (continued):

- Circuit 1 in panel 1 is system circuit 1. The circuit number is continuous from panel to panel. Continue numbering panels 2 through 4 (if present).

Panel 3		
Panel Circuit	System Circuit	Description
1		
2		
3		
4		
5		
6		
7		
8		
9		
10		
11		
12		
13		
14		
15		
16		
17		
18		
19		
20		
21		
22		
23		
24		
25		
26		
27		
28		
29		
30		
31		
32		
33		
34		
35		
36		

Panel 4		
Panel Circuit	System Circuit	Description
1		
2		
3		
4		
5		
6		
7		
8		
9		
10		
11		
12		
13		
14		
15		
16		
17		
18		
19		
20		
21		
22		
23		
24		
25		
26		
27		
28		
29		
30		
31		
32		
33		
34		
35		
36		



Panel Tables

Panel 5		
Panel Circuit	System Circuit	Description
1		
2		
3		
4		
5		
6		
7		
8		
9		
10		
11		
12		
13		
14		
15		
16		
17		
18		
19		
20		
21		
22		
23		
24		
25		
26		
27		
28		
29		
30		
31		
32		
33		
34		
35		
36		

Panel 6		
Panel Circuit	System Circuit	Description
1		
2		
3		
4		
5		
6		
7		
8		
9		
10		
11		
12		
13		
14		
15		
16		
17		
18		
19		
20		
21		
22		
23		
24		
25		
26		
27		
28		
29		
30		
31		
32		
33		
34		
35		
36		



Panel Tables

Panel 7		
Panel Circuit	System Circuit	Description
1		
2		
3		
4		
5		
6		
7		
8		
9		
10		
11		
12		
13		
14		
15		
16		
17		
18		
19		
20		
21		
22		
23		
24		
25		
26		
27		
28		
29		
30		
31		
32		
33		
34		
35		
36		

Panel 8		
Panel Circuit	System Circuit	Description
1		
2		
3		
4		
5		
6		
7		
8		
9		
10		
11		
12		
13		
14		
15		
16		
17		
18		
19		
20		
21		
22		
23		
24		
25		
26		
27		
28		
29		
30		
31		
32		
33		
34		
35		
36		



Module Type Table

How to Use this Table:

- Record the proper module types for each panel.

The LCP128™ Panel Model Number

The model number for each LCP128 panel in the system indicates the quantity and type of modules present in that panel.

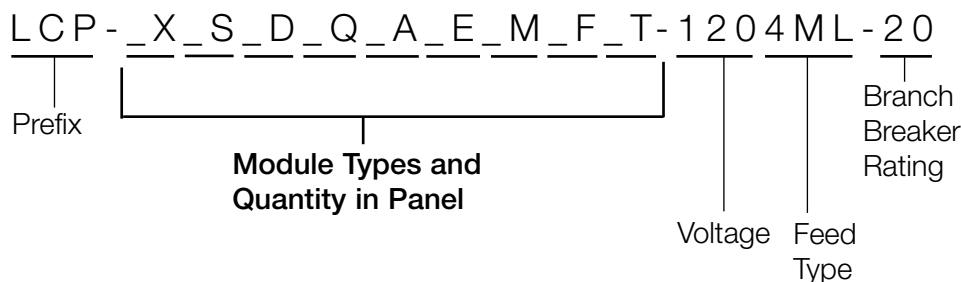

Module Types

- X** = 4-circuit Switching (Relay) (XP)
- S** = 1-Circuit Dimming (1U)
- D** = 2-Circuit Dimming (2U)
- Q** = 4-Circuit Dimming (4U)
- A** = 4-Circuit Adaptive Dimming (4A)
- E** = 4-Circuit Electronic Low Voltage Dimming (4E)
- M** = 4-Circuit Motor (4M)
- F** = 4-Circuit Quiet Fan Speed Module (4FSQ)
- T** = 0-10 V Ballast Control Module (TVM). TVM(s) allow switching or dimming modules to control 0-10 V, PWM, DSI, DALI (broadcast), 10-0 V, DIS LOG, or DALI LOG load types.

Example Model Number:

LCP-2S4Q-1204ML-20

Panel with two 1-output dimming modules (2S) and four 4-output dimming modules (4Q), for a total of six modules.

Module types not present are omitted from the model number.

Modules are located in the panel in the order they appear in the model number, starting at the top of the panel going down. Note the types of modules in each panel and use this information for Module Type Setup in STEP 1.

Panel 1		Panel 2		Panel 3		Panel 4		Panel 5		Panel 6		Panel 7		Panel 8	
Module	Type	Module	Type	Module	Type	Module	Type	Module	Type	Module	Type	Module	Type	Module	Type
1		1		1		1		1		1		1		1	
2		2		2		2		2		2		2		2	
3		3		3		3		3		3		3		3	
4		4		4		4		4		4		4		4	
5		5		5		5		5		5		5		5	
6		6		6		6		6		6		6		6	
7		7		7		7		7		7		7		7	
8		8		8		8		8		8		8		8	
9		9		9		9		9		9		9		9	

Note: Spec-grade panels have only GP cards for module types.



Load Type Table

How to Use This Table:

- Refer to the load schedule for each panel and record the proper load type setting for each circuit.

Each circuit in every *LCP128* panel must be assigned a load type (see STEP 1 earlier in this guide). The load types available for each circuit depend upon the module type that provides that circuit. Below are the available load types.

Module Type	Load Type(s)	Description
X (XP)	Non-Dim	Light levels toggle between on and off with no intermediate dimming levels.
S / D / Q (1U / 2U / 4U)	Incandescent	For tungsten filament lamps.
	Magnetic Low Voltage (MLV)	For magnetic transformer low-voltage lighting.
	Tu-Wire	For fluorescent lamps equipped with Lutron Tu-Wire® dimming ballasts.
	Electronic Low Voltage (ELV)	For use with electronic transformer low-voltage lighting. Requires Lutron ELVI-1000 external interface.
	Non-Dim	Non-Dim
E (4E)	Electronic Low Voltage (ELV)	For use with electronic transformer low-voltage lighting.
A (4A)	Adaptive dimming module	For use with tungsten (incandescent) lamps, electronic low-voltage, magnetic low-voltage, neon.
M (4M)	Motor	For controlling motors.
F (4FSQ)	Fan	For controlling fan speed.
T (TVM)	0-10 V; 10-0 V	For dimming ballasts with 0-10 V _{DC} control.
	PWM	For dimming ballasts with PWM control.
	Tridonic® DSI; DIS LOG	For dimming ballasts with Tridonic DSI control.
	DALI (broadcast only); DALI LOG	For dimming ballasts with DALI control. Broadcast only.
GP card (spec-grade only)	Incandescent	For tungsten filament lamps.
	Magnetic Low Voltage (MLV)	For magnetic transformer low-voltage lighting.
	Tu-Wire	For fluorescent lamps equipped with Lutron Tu-Wire® dimming ballasts.
	Electronic Low Voltage (ELV)	For use with electronic transformer low-voltage lighting. Requires Lutron ELVI-1000 external interface.
	Non-Dim	Non-Dim
	Hi-Lume FDB	Fluorescent dimming ballast
	Eco-10	Fluorescent dimming ballast
	Neon	For neon lighting
TVM loads	See above	

If a power interface is being used in your system, please use the following table to determine which load type is to be selected on the *LCP128* controller.

Load Type	Lutron Interface	Load Type Setting	Maximum Attached Load
Electronic Low Voltage (ELV)	ELVI-1000	ELV	960 W
Lutron Hi-lume® Ballasts	GRX-FDBI-16A-120	Tu-Wire	1920 W
0-10 V _{DC} Ballasts	GRX-TVI	Tu-Wire	300 mA (sink max), 1920 W switched
<2000 W of Incandescent MLV, Halogen, Tu-Wire	NGRX-PB-WH	Incandescent	2000 W
>2000 W of Incandescent MLV, Halogen, Tu-Wire, Hi-lume	HP-2, HP-4, HP-6	Incandescent	2000 W, 4000 W, 6000 W



Control Location Table

How to Use This Table:

- For each control station, fill in the number of buttons and a brief description or location.

Address	Number of Buttons	Location / Description
1		
2		
3		
4		
5		
6		
7		
8		
9		
10		
11		
12		
13		
14		
15		
16		
17		
18		
19		
20		
21		
22		
23		
24		
25		
26		
27		
28		
29		
30		
31		
32		

Contact Information Warranty

Internet: www.lutron.com
E-mail: product@lutron.com

WORLD HEADQUARTERS **USA**

Lutron Electronics Co., Inc.
7200 Suter Road, Coopersburg, PA 18036-1299
TEL +1.610.282.3800
FAX +1.610.282.1243
Toll-Free 1.888.LUTRON1
Technical Support 1.800.523.9466

Brazil

Lutron BZ do Brasil Ltda.
AV, Brasil, 239, Jardim America
Sao Paulo-SP, CEP: 01431-000, Brazil
TEL +55.11.3885.5152
FAX +55.11.3887.7138

North and South America Technical Hotlines

USA, Canada, Caribbean: 1.800.523.9466
Mexico: +1.888.235.2910
Central/South America: +1.610.282.6701

EUROPEAN HEADQUARTERS

United Kingdom

Lutron EA Ltd.
6 Sovereign Close, London, E1W 3JF United Kingdom
TEL +44.(0)20.7702.0657
FAX +44.(0)20.7480.6899
FREEPHONE (UK) 0800.282.107
Technical support +44.(0)20.7680.4481

WORLDWIDE OFFICES

France

Lutron LTC, S.A.R.L.
90 rue de Villiers, 92300 Levallois-Perret France
TEL +33.(0)1.41.05.42.80
FAX +33.(0)1.41.05.01.80
FREEPHONE 0800.90.12.18

Germany

Lutron Electronics GmbH, Landsberger Allee 201,
13055 Berlin, Germany
TEL +49.(0)30.9710.4590
FAX +49.(0)30.9710.4591
FREEPHONE 00800.5887.6635

Italy

Lutron LDV, S.r.l.
FREEPHONE 800.979.208

Spain, Barcelona

Lutron CC, S.R.L.
Gran Via del Carlos III, 84, planta 3ª,
08028, Barcelona, Spain
TEL +34.93.496.57.42
FAX +34.93.496.57.01
FREEPHONE 0900.948.944

Spain, Madrid

Lutron CC, S.R.L.
Calle Orense, 85, 28020 Madrid, Spain
TEL +34.91.567.84.79
FAX +34.91.567.84.78
FREEPHONE 0900.948.944

ASIAN HEADQUARTERS

Singapore

Lutron GL Ltd.
15 Hoe Chiang Road, #07-03 Euro Asia Centre,
Singapore 089316
TEL +65.6220.4666
FAX +65.6220.4333

China, Beijing

Lutron GL Ltd. Beijing Representative Office
5th Floor, China Life Tower
No. 16 Chaowai Street, Chaoyang District, Beijing
100020 China
TEL +86.10.5877.1817
FAX +86.10.5877.1816

China, Guangzhou

Lutron GL Ltd. Guangzhou Representative Office
Suite A09, 23/F Tower A, Centre Plaza
161 Lin He Xi Lu, Tian He District, Guangzhou
510620 China
TEL +86.20.2885.8266
FAX +86.20.2885.8366

China, Shanghai

Lutron GL Ltd., Shanghai Representative Office
Suite 07, 39th Floor, Plaza 66
1266 Nan Jing West Road, Shanghai, 200040 China
TEL +86.21.6288.1473
FAX +86.21.6288.1751

Hong Kong

Lutron GL Ltd.
Unit 2808, 28/F, 248 Queen's Road East
Wanchai, Hong Kong
TEL +852.2104.7733
FAX +852.2104.7633

Japan

Lutron Asuka Co. Ltd.
No. 16 Kowa Building, 4F, 1-9-20
Akasaka, Minato-ku, Tokyo 107-0052 Japan
TEL +81.3.5575.8411
FAX +81.3.5575.8420
FREEPHONE 0120.083.417

Asia Technical Hotlines

Northern China: 10.800.712.1536
Southern China: 10.800.120.1536
Hong Kong: 800.901.849
Japan: +81.3.5575.8411
Singapore: 800.120.4491
Taiwan: 00.801.137.737
Thailand: 001.800.120.665853
Other countries: +800.120.4491

Lutron Electronics Co., Inc. One Year Limited Warranty

For a period of one year from the date of purchase, and subject to the exclusions and restrictions described below, Lutron warrants each new unit to be free from manufacturing defects. Lutron will, at its option, either repair the defective unit or issue a credit equal to the purchase price of the defective unit to the Customer against the purchase price of comparable replacement part purchased from Lutron. Replacements for the unit provided by Lutron or, at its sole discretion, an approved vendor may be new, used, repaired, reconditioned, and/or made by a different manufacturer.

If the unit is commissioned by Lutron or a Lutron approved third party as part of a Lutron commissioned lighting control system, the term of this warranty will be extended, and any credits against the cost of replacement parts will be prorated, in accordance with the warranty issued with the commissioned system, except that the term of the unit's warranty term will be measured from the date of its commissioning.

EXCLUSIONS AND RESTRICTIONS

This Warranty does not cover, and Lutron and its suppliers are not responsible for:

1. Damage, malfunction or inoperability diagnosed by Lutron or a Lutron approved third party as caused by normal wear and tear, abuse, misuse, incorrect installation, neglect, accident, interference or environmental factors, such as (a) use of incorrect line voltages, fuses or circuit breakers; (b) failure to install, maintain and operate the unit pursuant to the operating instructions provided by Lutron and the applicable provisions of the National Electrical Code and of the Safety Standards of Underwriter's Laboratories; (c) use of incompatible devices or accessories; (d) improper or insufficient ventilation; (e) unauthorized repairs or adjustments; (f) vandalism; or (g) an act of God, such as fire, lightning, flooding, tornado, earthquake, hurricane or other problems beyond Lutron's control.
2. On-site labor costs to diagnose issues with, and to remove, repair, replace, adjust, reinstall and/or reprogram the unit or any of its components.
3. Equipment and parts external to the unit, including those sold or supplied by Lutron (which may be covered by a separate warranty).
4. The cost of repairing or replacing other property that is damaged when the unit does not work properly, even if the damage was caused by the unit.

EXCEPT AS EXPRESSLY PROVIDED IN THIS WARRANTY, THERE ARE NO EXPRESS OR IMPLIED WARRANTIES OF ANY TYPE, INCLUDING ANY IMPLIED WARRANTIES OF FITNESS FOR A PARTICULAR PURPOSE OR MERCHANTABILITY. LUTRON DOES NOT WARRANT THAT THE UNIT WILL OPERATE WITHOUT INTERRUPTION OR BE ERROR FREE.

NO LUTRON AGENT, EMPLOYEE OR REPRESENTATIVE HAS ANY AUTHORITY TO BIND LUTRON TO ANY AFFIRMATION, REPRESENTATION OR WARRANTY CONCERNING THE UNIT. UNLESS AN AFFIRMATION, REPRESENTATION OR WARRANTY MADE BY AN AGENT, EMPLOYEE OR REPRESENTATIVE IS SPECIFICALLY INCLUDED HEREIN, OR IN STANDARD PRINTED MATERIALS PROVIDED BY LUTRON, IT DOES NOT FORM A PART OF THE BASIS OF ANY BARGAIN BETWEEN LUTRON AND CUSTOMER AND WILL NOT IN ANY WAY BE ENFORCEABLE BY CUSTOMER.

IN NO EVENT WILL LUTRON OR ANY OTHER PARTY BE LIABLE FOR EXEMPLARY, CONSEQUENTIAL, INCIDENTAL OR SPECIAL DAMAGES (INCLUDING, BUT NOT LIMITED TO, DAMAGES FOR LOSS OF PROFITS, CONFIDENTIAL OR OTHER INFORMATION, OR PRIVACY; BUSINESS INTERRUPTION; PERSONAL INJURY; FAILURE TO MEET ANY DUTY, INCLUDING OF GOOD FAITH OR OF REASONABLE CARE; NEGLIGENCE; OR ANY OTHER PECUNIARY OR OTHER LOSS WHATSOEVER), NOR FOR ANY REPAIR WORK UNDERTAKEN WITHOUT LUTRON'S WRITTEN CONSENT ARISING OUT OF OR IN ANY WAY RELATED TO THE INSTALLATION, DEINSTALLATION, USE OF OR INABILITY TO USE THE UNIT OR OTHERWISE UNDER OR IN CONNECTION WITH ANY PROVISION OF THIS WARRANTY, OR ANY AGREEMENT INCORPORATING THIS WARRANTY, EVEN IN THE EVENT OF THE FAULT, TORT (INCLUDING NEGLIGENCE), STRICT LIABILITY, BREACH OF CONTRACT OR BREACH OF WARRANTY OF LUTRON OR ANY SUPPLIER, AND EVEN IF LUTRON OR ANY OTHER PARTY WAS ADVISED OF THE POSSIBILITY OF SUCH DAMAGES.

NOTWITHSTANDING ANY DAMAGES THAT CUSTOMER MIGHT INCUR FOR ANY REASON WHATSOEVER (INCLUDING, WITHOUT LIMITATION, ALL DIRECT DAMAGES AND ALL DAMAGES LISTED ABOVE), THE ENTIRE LIABILITY OF LUTRON AND OF ALL OTHER PARTIES UNDER THIS WARRANTY ON ANY CLAIM FOR DAMAGES ARISING OUT OF OR IN CONNECTION WITH THE MANUFACTURE, SALE, INSTALLATION, DELIVERY, USE, REPAIR, OR REPLACEMENT OF THE UNIT, OR ANY AGREEMENT INCORPORATING THIS WARRANTY, AND CUSTOMER'S SOLE REMEDY FOR THE FOREGOING, WILL BE LIMITED TO THE AMOUNT PAID TO LUTRON BY CUSTOMER FOR THE UNIT. THE FOREGOING LIMITATIONS, EXCLUSIONS AND DISCLAIMERS WILL APPLY TO THE MAXIMUM EXTENT ALLOWED BY APPLICABLE LAW, EVEN IF ANY REMEDY FAILS ITS ESSENTIAL PURPOSE.

TO MAKE A WARRANTY CLAIM

To make a warranty claim, promptly notify Lutron within the warranty period described above by calling the Lutron Technical Support Center at (800) 523-9466. Lutron, in its sole discretion, will determine what action, if any, is required under this warranty. To better enable Lutron to address a warranty claim, have the unit's serial and model numbers available when making the call. If Lutron, in its sole discretion, determines that an on-site visit or other remedial action is necessary, Lutron may send a Lutron Services Co. representative or coordinate the dispatch of a representative from a Lutron approved vendor to Customer's site, and/or coordinate a warranty service call between Customer and a Lutron approved vendor.

This warranty gives you specific legal rights, and you may also have other rights which vary from state to state. Some states do not allow limitations on how long an implied warranty lasts, so the above limitation may not apply to you. Some states do not allow the exclusion or limitation of incidental or consequential damages, so the above limitation or exclusion may not apply to you.

This warranty gives you specific legal rights, and you may also have other rights which vary from state to state. Some states do not allow limitations on how long an implied warranty lasts, so the above limitation may not apply to you. Some states do not allow the exclusion or limitation of incidental or consequential damages, so the above limitation or exclusion may not apply to you. This product may be covered by one or more of the following U.S. patents: 5,309,068; 5,633,540; 5,808,417; 6,046,550; 6,091,205; 6,188,181; 6,347,028; 6,380,692; and corresponding foreign patents. U.S. and foreign patents pending.

Lutron, the sunburst logo, Tu-Wire, and Hi-lume are registered trademarks; LCP128 is a trademark of Lutron Electronics Co., Inc. © 2006 Lutron Electronics Co., Inc.

