

Wired Architrave™ Keypads

24 V_{AC} 30 mA IEC PELV / NEC® Class 2
Typical Power Consumption*: 0.6 W

Installation Instructions

Please Read Before Installing

HQWA-KP5-DW-WH HQWA-KP7-DW-WH
 HQWA-KP5-DW-BL HQWA-KP7-DW-BL
 HQWA-KP5-DN-WH HQWA-KP7-DN-WH
 HQWA-KP5-DN-BL HQWA-KP7-DN-BL

Use these instructions to install the model numbers listed above.

Important Notes

Codes: Install in accordance with all local and national electrical codes.

Environment: Ambient operating temperature: 32 °F to 104 °F (0 °C to 40 °C), 0 to 90% humidity, non-condensing. Indoor use only.

Faceplates: Use Lutron® Architrave™ faceplates (sold separately). Architrave™ faceplates snap on with no visible means of attachment.

Cleaning: To clean, wipe with a clean damp cloth. DO NOT use any chemical cleaning solutions.

Wallboxes: Architrave™ Wallbox P/N 241399 (sold separately), 4.4 in (111.76 mm) tall by 1.25 in (31.75 mm) wide by 2.75 in (69.85 mm) deep.

Keypad Wiring

- The total length of wire on a HomeWorks® QS wired link is not to exceed 2000 ft (610 m).
- Up to 100 devices can be connected to the HomeWorks® QS wired link. This can include seeTouch® keypads along with other devices as defined in the HomeWorks® QS software.
- Wiring may be in a daisy-chain, star, or T-tap configuration.
- Control wire must be 1 pair 18 AWG (1.0 mm²) IEC PELV / NEC® Class 2 for power and 1 pair 22 to 18 AWG (0.5 to 1.0 mm²) IEC PELV / NEC® Class 2 twisted/shielded for data (see **Wiring Diagram**).

System Programming: Programming and activation (addressing) must be accomplished through the HomeWorks® QS software.

Engraving: Refer to the HomeWorks® QS software for engraving instructions.

*Typical Power Consumption test conditions: all backlights on medium intensity, two LEDs on (two presets active), keypad powered at 24 V_{AC}.

Technical Assistance:
 U.S.A. / Canada: 1.800.523.9466
 Mexico: +1.888.235.2910
 Other Countries: +1.610.282.3800
 24 hours a day, 7 days a week.



Installation

CAUTION: Minor Shock Hazard. Could cause minor injury or damage equipment. Turn OFF power at circuit breaker before installing the unit.

- Disconnect power to the keypads by turning OFF all circuit breakers connected to the HomeWorks® QS processor or HomeWorks® QS wired link auxiliary power supplies.
- Connect to HomeWorks® QS wired link.
 - Strip insulation 3/8 in (10 mm).
 - Unplug keypad link terminal block from the back of the keypad.
 - Connect wiring to terminal block as shown in the **Wiring Diagram**. Each terminal will accept one or two 18 AWG (1.0 mm²) wires.
 - Plug the keypad link terminal block back onto the keypad. Be sure to orient the terminal block correctly.
- Connect external input closures: Connect up to two low-voltage dry contact closures (see **Wiring Diagram**).

Wiring Diagram

IEC PELV / NEC® Class 2 control wiring:
 18 AWG (1.0 mm²)
 Data link: twisted, shielded pair 22 to 18 AWG
 (0.5 to 1.0 mm²)

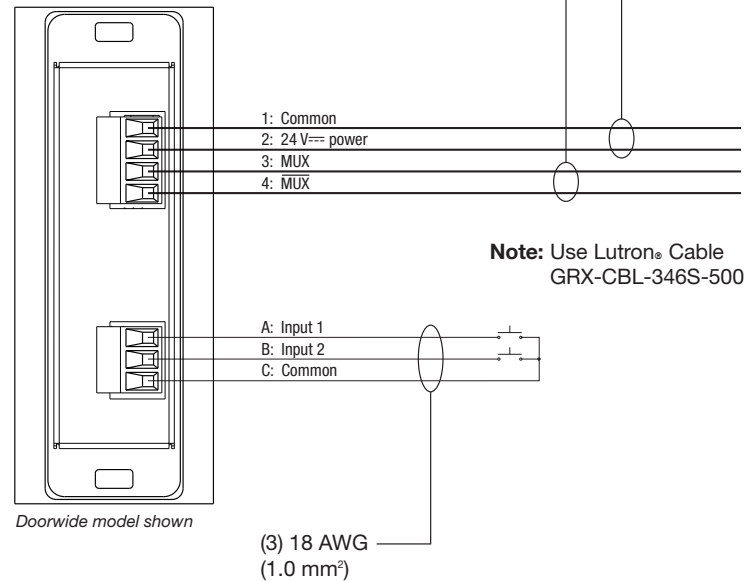

Note: When using the input contact closures, verify compatibility of external contact closure input devices. The contact closure inputs can be used with either dry contact closures or ground-referenced solid-state outputs. The outputs must stay in the closed or open states for at least 40 ms in order to be recognized by the keypad. If there is any question as to whether the device is compatible with these specifications, contact the manufacturer.

Mounting

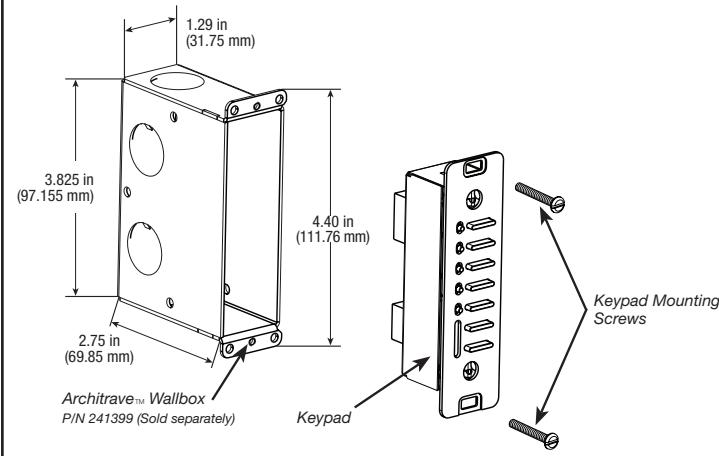

- Push all wires back into the wallbox (Architrave™ Wallbox P/N 241399) and insert and tighten the keypad to the wallbox using the keypad mounting screws provided (do not overtighten). Do not pinch the wires.

Note: Wallboxes ordered separately
P/N 241399 Architrave Wallbox

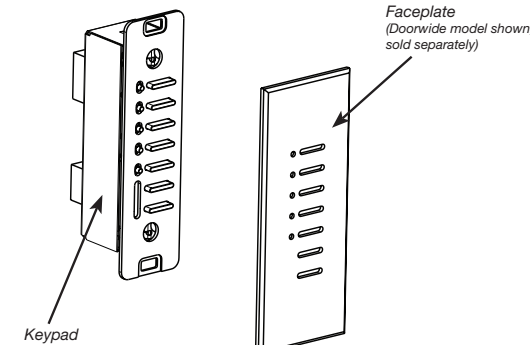

- Ensure proper faceplate positioning and alignment, then insert and snap the faceplate into position.

Note: Faceplates ordered separately

- Restore power.

Troubleshooting Guide

Symptom	Possible Causes
No communication with HomeWorks® QS processor	<ul style="list-style-type: none"> Miswire or loose connection at the HomeWorks® QS wired link. Keypad has not been programmed or has been programmed incorrectly.
Keypad buttons do not work; LEDs do not track.	<ul style="list-style-type: none"> Keypad is miswired. Keypad is not powered. Keypad has not been programmed or has been programmed incorrectly.
LEDs do not turn on.	<ul style="list-style-type: none"> Miswire or loose connection at the keypad(s) or processor on the HomeWorks® QS wired link. Keypad has been programmed incorrectly.
Contact closure inputs do not produce the desired result in the system.	<ul style="list-style-type: none"> Miswire or loose connection at the keypad CCI connector. Keypad has not been programmed or has been programmed incorrectly.
Keypad buttons do not function as intended.	<ul style="list-style-type: none"> Keypad has not been programmed or has been programmed incorrectly.
Keypad LEDs scroll quickly from bottom to top.	<ul style="list-style-type: none"> A communication issue is preventing the keypad from receiving an ID from the system. There are more than 100 devices on the link.

Returning Keypads to Factory Settings

Returning a keypad to its Factory Settings will remove the keypad from the system and erase all programming.

Step 1: Triple tap any button on the keypad (except raise/lower). DO NOT release after third tap.

Step 2: Keep the button pressed on the third tap until all the status LEDs start to flash slowly (approximately 3 seconds).

Step 3: Immediately release the button and triple tap the button again. The status LEDs on the keypad will flash quickly.

The keypad has now been returned to Factory Settings.

Warranty:

For warranty information, please see the Warranty enclosed with the product, or visit: www.lutron.com/TechnicalDocumentLibrary/HomeWorks_Warranty.pdf