

Lutron® roller 64 dual mount chassis

English

Installation Guide (please read before installing)

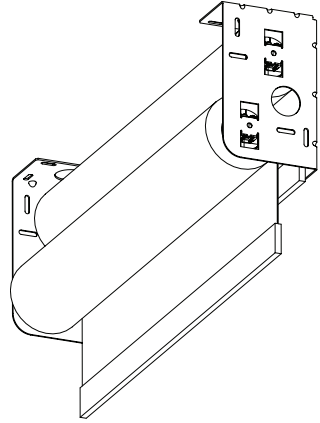

The roller 64 Dual Mount Chassis Installation Guide is a complement to the enclosed Basic Wiring and Setup Guide. The Chassis Installation Guide describes the mechanical installation. The Basic Wiring and Setup Guide describes the wiring and setup for basic function of the roller shade.

Tools required:

- Tape Measure
- 1/4 in Hex-Head Driver
- #2 Phillips Screwdriver
- Level
- Power Drill

Box Contents:

(2) Lutron roller 64 shades



Left and right dual brackets

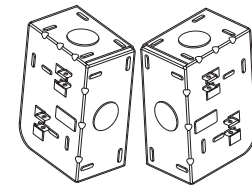

(3) 4 in (102 mm) Cable ties



(2) Cable tie anchors

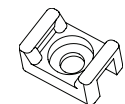

(10) Mounting screws
(#8x1.75 in)



CAUTION: Risk of falling objects. Securely install the roller shade system per the mounting instructions. Failure to do so could result in minor or moderate injury.

Notes:

- Lutron systems are intended for use with only Lutron hardware, controls, and power supplies.
- **Codes:** Install in accordance with all local and national electrical codes.
- **Environment:** Ambient operating temperature: 32 °F - 104 °F (0 °C - 40 °C), 0 - 90% humidity, non-condensing. Indoor use only.
- Maintain sufficient clearance between the moving shade and any object.

1 Position the mounting brackets

- 1.1 Mark the location of the mounting brackets so that they are centered over the window, ensuring that you are mounting to a structural member, such as a stud.

Notes:

- Bracket to bracket distance = Fabric Width + 1.5 in (38 mm) = System Width.
- Do not use the uninstalled shade to determine the bracket location. Always use the system width to determine bracket location. There is an idler spring that compresses during shade installation that allows the shade to fit within the system width.
- For ceiling and jamb mount, allow clearance to prevent the fabric from rubbing against the trim, window, top treatment, etc. Wall mount may require blocks (not provided) to clear the trim.

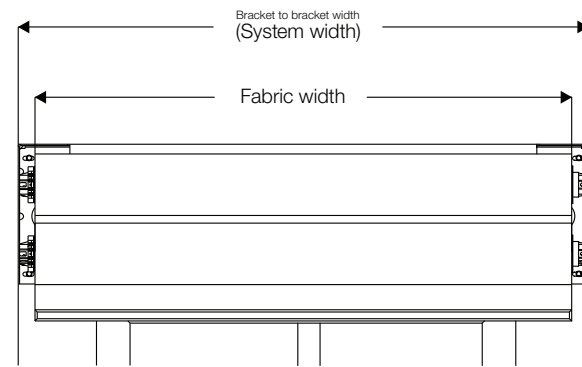

2 Pre-drill for cable run

- 2.1 Choose one of the three options below to drill for cable access.

Notes:

- Cables may exit through any of the large holes in the dual brackets, on the Drive side of the shades.
- Leave 12-18 in (30-45 cm) of cable exposed for each of the two shades.

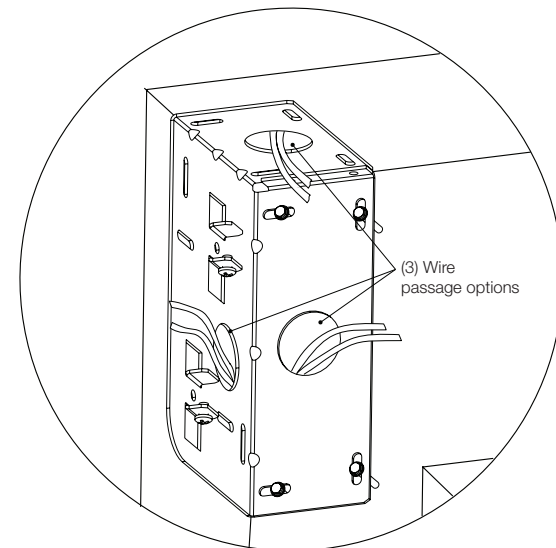

3 Install dual brackets

- 3.1 Install the first mounting bracket with the bracket oriented such that the upper shade mount is closest to the glass.

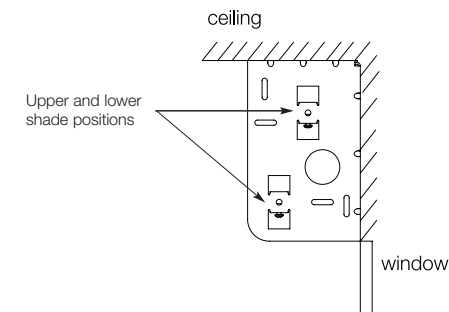

- 3.2 Install the second mounting bracket as shown in the figure below.

Notes:

- Each bracket should use four mounting screws, in either the ceiling holes or the wall holes.
- The brackets should be mounted to support at least 300 lbs (136 kg). The fasteners provided may not be appropriate for use in all applications.

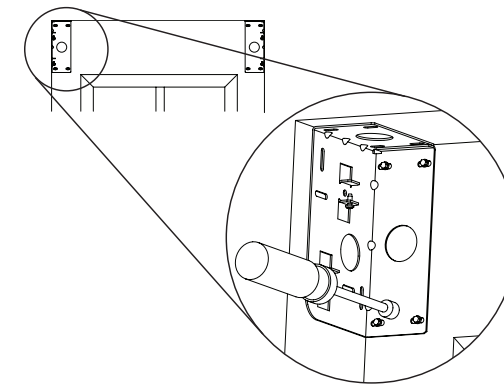

4 Orient the buttons and wiring

- 4.1 For the following bracket and button orientations, route the wires as shown.

Notes:

- The buttons should be accessible when the shade is installed.
- Make sure the wires are not pinched or damaged.
- The wires may go in either of the indicated slots.

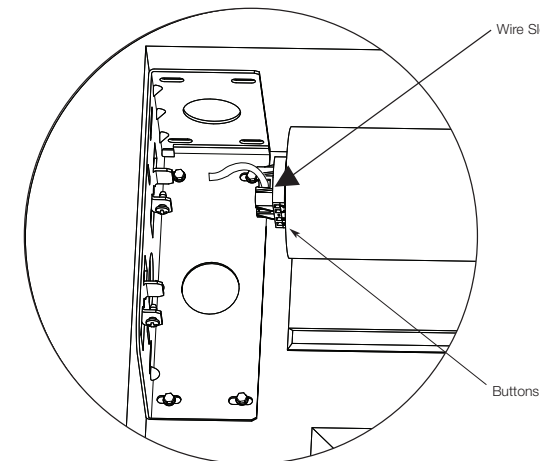

5 Mount the top shade

- 5.1 Install the idler side of the top shade onto its bracket.

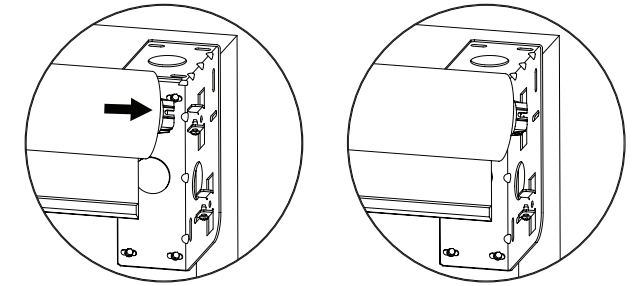

- 5.2 Depress the spring-loaded idler (shown in 5.1) by pressing the shade towards the idler, and install the Drive side of the shade onto its bracket.

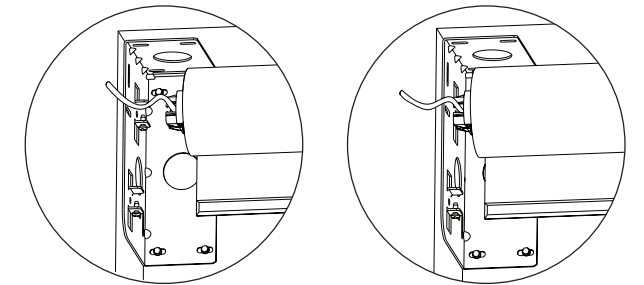

6 Adjust the shade

- 6.1 Ensure that the shade is level and centered by shimming the bracket.
Note: You do not need to level the second shade.

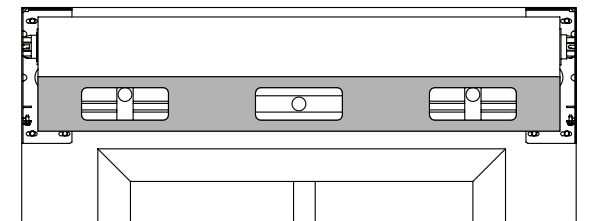

- 6.2 Adjust shade by removing the necessary screws and moving the brackets as needed.
Note: You may have to remove the shade to access the bracket screws.

- 6.3 Reinstall and tighten the screws.

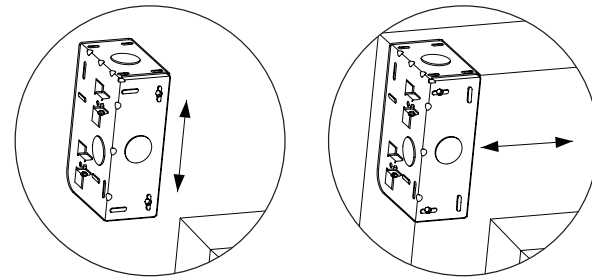

Note: Arrange wires in a location that prevents them from interfering with moving shade.

7 Secure the shade

- 7.1 Tighten retaining screws in each bracket to secure the shade.

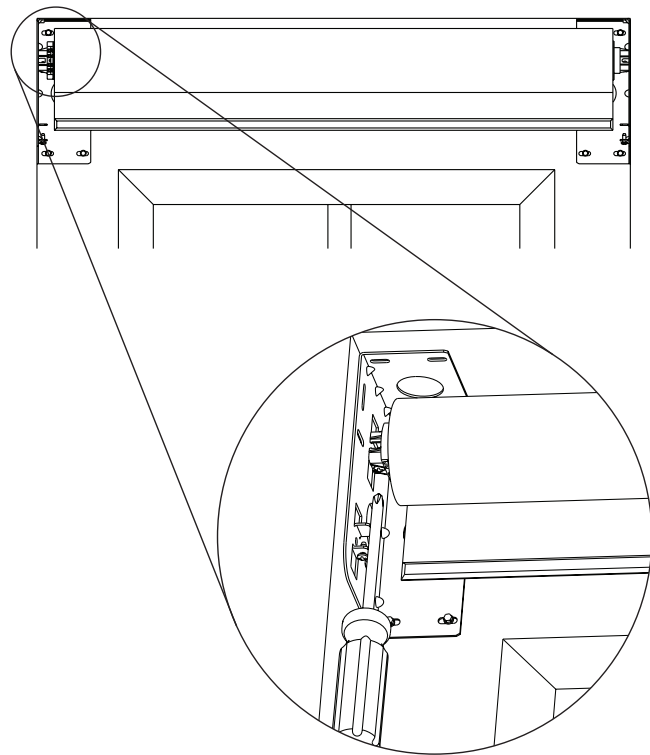

8 Wiring and basic setup

- 8.1 Refer to the Basic Wiring and Setup Guide included with the roller shade system for wiring instructions and setup including setting open and close limits.

9 Check shade for telescoping

- 9.1 Use the programming stylus to run the shade up and down using the adjustment buttons (↕), re-level if needed.

Note: Monitor fabric as it rolls up on the tube to ensure that it does not telescope excessively to one side or the other.

Slight telescoping is normal. However, if the shade is telescoping severely to one side and it is level, tap the “Close Limit Button” (■), and lower the shade all the way down using the adjustment buttons (↕). Place a piece of tape on the side of the tube that the fabric is telescoping away from, tap the “Close Limit Button” (■) once to exit. This technique is referred to as “SHIMMING”. The shade will always track towards the side with the tape (shim).

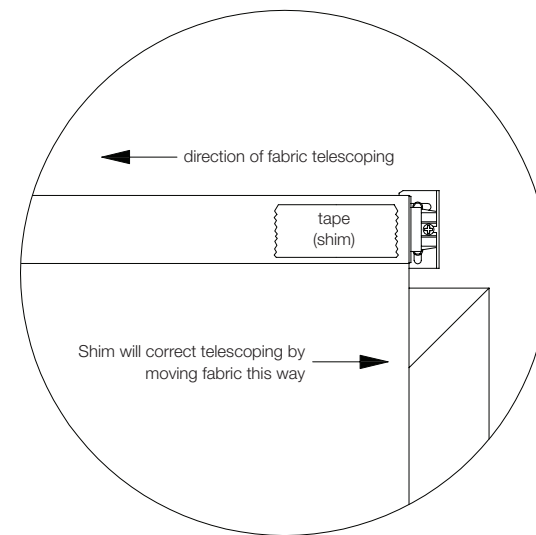

10 Install the second shade

- 10.1 Install the lower shade by repeating steps 4-9



11 Troubleshooting

Symptom	Solution
Fabric is not level.	Verify the brackets are mounted level
Fabric is not centered over window.	Verify the brackets are centered
Shade does not move smoothly.	Verify the shade fabric is not obstructed by the side channels or any other object
Shade will not move to open or full close	Verify that open and close limits are set correctly Verify that shade fabric is not obstructed or caught on something

Limited Warranty

SCOPE

This limited warranty (“Warranty”) covers the Lutron supplied (a) Sivoia® QS Shade System (“Sivoia® QS Shade System”), (b) Sivoia QED™ Shade System (“Sivoia QED™ Shade System”), (c) manual shade system and (d) alternating current or a/c shade system (each of the foregoing being a “System”). Customer acknowledges and agrees that use of the System constitutes acceptance of all terms and conditions of this Warranty.

LIMITED WARRANTY

Subject to the exclusions and restrictions described below, Lutron warrants that each System will be free from manufacturing defects from the date of shipment by Lutron for a period of (a) one year as to the wall controls, interfaces and system accessories of the Sivoia QS Shade System (“External Sivoia QS Components”) and (b) eight years as to the other Systems and the Roller Shade EDU, shade fabric and shade hardware of the Sivoia QS Shade System. If any manufacturing defect exists in the External Sivoia QS Components, so long as Customer promptly notifies Lutron of the defect within the one year warranty period and, if requested by Lutron, returns the defective part(s), Lutron will, at its option, either repair the defective part(s) or provide comparable replacement part(s). If any manufacturing defect exists in any of the components of a System other than the External Sivoia QS Components, so long as Customer promptly notifies Lutron of the defect within the eight year warranty period and, if requested by Lutron, returns the defective part(s), Lutron will, at its option, either repair the defective part(s) or issue a credit to the Customer against the purchase price of comparable replacement part(s) purchased from Lutron as provided below:

Number of years from date of shipment	Percentage of cost of replacement parts credited by Lutron
Up to 5	100%
More than 5 but not more than 8	50%
More than 8	0%

Replacement parts for the System provided by Lutron or, at its sole discretion, an approved vendor may be new, used, repaired, reconditioned, and/or made by a different manufacturer.

EXCLUSIONS AND RESTRICTIONS

This Warranty will be void, and Lutron and its suppliers will have no responsibility under this Warranty, if Lutron or its representatives cannot access any components of the System to inspect, diagnose problems with or repair the System or any of its components as a result of concealment or inaccessibility of such components within a building structure. This Warranty does not cover, and Lutron and its suppliers are not responsible for:

1. Damage, malfunction or inoperability diagnosed by Lutron or a Lutron approved third party as caused by normal wear and tear, abuse, misuse, incorrect installation, neglect, accident, interference or environmental factors, such as (a) use of incorrect line voltages fuses or circuit breakers; (b) failure to install, maintain and operate the System pursuant to the operating instructions provided by Lutron and the applicable provisions of the National Electrical Code and of the Safety Standards of Underwriter’s Laboratories; (c) use of incompatible devices or accessories; (d) improper or insufficient ventilation; (e) unauthorized repairs or adjustments or alterations; (f) vandalism; (g) an act of God, such as fire, lightning, flooding, tornado, earthquake, hurricane or other problems beyond Lutron’s control; or (h) direct exposure to corrosive materials.
2. On-site labor costs to diagnose issues with, and remove, repair, replace, adjust, reinstall and/or reprogram the System or any of its components.
3. Components and equipment external to the System, such as, non-Lutron lighting and automation systems; building wiring audiovisual equipment; and non-Lutron time clocks, photosensors and motion detectors.
4. The cost of repairing or replacing other property that is damaged when any System does not work properly, even if the damage was caused by the System.

THIS WARRANTY IS IN LIEU OF ALL OTHER EXPRESS WARRANTIES. ALL IMPLIED WARRANTIES, INCLUDING THE IMPLIED WARRANTIES OF MERCHANTABILITY AND OF FITNESS FOR A PARTICULAR PURPOSE, ARE LIMITED TO EIGHT YEARS FROM THE DATE OF SHIPMENT, EXCEPT THAT SUCH IMPLIED WARRANTIES ARE LIMITED TO ONE YEAR FROM THE DATE OF SHIPMENT AS TO THE EXTERNAL SIVOIA QS COMPONENTS. NO LUTRON AGENT, EMPLOYEE OR REPRESENTATIVE HAS ANY AUTHORITY TO BIND LUTRON TO ANY AFFIRMATION, REPRESENTATION OR WARRANTY CONCERNING THE SYSTEMS. UNLESS AN

AFFIRMATION, REPRESENTATION OR WARRANTY MADE BY AN AGENT, EMPLOYEE OR REPRESENTATIVE IS SPECIFICALLY INCLUDED HEREIN, OR IN STANDARD PRINTED MATERIALS PROVIDED BY LUTRON, IT DOES NOT FORM A PART OF THE BASIS OF ANY BARGAIN BETWEEN LUTRON AND CUSTOMER AND WILL NOT IN ANY WAY BE ENFORCEABLE BY CUSTOMER. IN NO EVENT WILL LUTRON OR ANY OTHER PARTY BE LIABLE FOR EXEMPLARY, CONSEQUENTIAL, INCIDENTAL OR SPECIAL DAMAGES (INCLUDING, BUT NOT LIMITED TO DAMAGES FOR PERSONAL INJURY, FAILURE TO MEET ANY DUTY, INCLUDING OF GOOD FAITH OR REASONABLE CARE, NEGLIGENCE, OR ANY OTHER LOSS WHATSOEVER), NOR FOR ANY REPAIR WORK UNDERTAKEN WITHOUT LUTRON’S PRIOR WRITTEN CONSENT ARISING OUT OF OR IN ANY WAY RELATED TO THE INSTALLATION, DEINSTALLATION, USE OF OR INABILITY TO USE THE SYSTEM OR OTHERWISE UNDER OR IN CONNECTION WITH ANY PROVISION OF THIS WARRANTY, EVEN IN THE EVENT OF THE FAULT, TORT (INCLUDING NEGLIGENCE), STRICT LIABILITY, BREACH OF CONTRACT OR BREACH OF WARRANTY OF LUTRON OR ANY OTHER PARTY, AND EVEN IF LUTRON OR SUCH OTHER PARTY WAS ADVISED OF THE POSSIBILITY OF SUCH DAMAGES. NOTWITHSTANDING ANY DAMAGES THAT CUSTOMER MIGHT INCUR FOR ANY REASON WHATSOEVER (INCLUDING, WITHOUT LIMITATION, ALL DIRECT DAMAGES AND ALL DAMAGES LISTED ABOVE), THE ENTIRE LIABILITY OF LUTRON AND OF ALL OTHER PARTIES UNDER THIS WARRANTY ON ANY CLAIM FOR DAMAGES ARISING OUT OF OR IN CONNECTION WITH THE MANUFACTURE, SALE, INSTALLATION, DELIVERY, USE, REPAIR, OR REPLACEMENT OF THE SYSTEM, AND CUSTOMER’S SOLE REMEDY FOR THE FOREGOING, WILL BE LIMITED TO THE AMOUNT PAID BY CUSTOMER FOR THE SYSTEM. THE FOREGOING LIMITATIONS, EXCLUSIONS AND DISCLAIMERS WILL APPLY TO THE MAXIMUM EXTENT ALLOWED BY APPLICABLE LAW, EVEN IF ANY REMEDY FAILS ITS ESSENTIAL PURPOSE. THIS WARRANTY GIVES YOU SPECIFIC LEGAL RIGHTS. YOU MAY ALSO HAVE OTHER RIGHTS WHICH VARY FROM STATE TO STATE. SOME STATES DO NOT ALLOW LIMITATIONS ON HOW LONG AN IMPLIED WARRANTY LASTS OR THE EXCLUSION OR LIMITATION OF INCIDENTAL OR CONSEQUENTIAL DAMAGES, SO THE ABOVE LIMITATIONS OR EXCLUSIONS MAY NOT APPLY TO YOU. WARRANTY CLAIMS, TECHNICAL ASSISTANCE AND WARRANTY INFORMATION.

Contact the Lutron Technical Support Center at the numbers provided below or your local Lutron sales representative with questions concerning the installation or operation of the System or this Warranty, or to make a warranty claim. Please provide the exact model number when calling. Lutron and  are registered trademarks of Lutron Electronics Co., Inc.

Worldwide Headquarters | USA

Lutron Electronics Co., Inc.
7200 Suter Road
Coopersburg, PA 18036-1299 USA
TEL: 1.610.282.3800
FAX: 1.610.282.3090
Technical Support: 1.800.523.9466 or 1.610.282.6701
Toll Free: 1.888.LUTRON1
EMAIL: shadinginfo@lutron.com
WEB: www.lutron.com/shadingsolutions

Europe Headquarters | United Kingdom

Lutron EA Ltd
6 Sovereign Close
London, E1W 3JF, UK
TEL: +44.(0)20.7702.0657
FAX: +44.(0)20.7480.6899
Technical Support: +44.(0)20.7680.4481
FREEPHONE: 0800.282.107

Asian Headquarters | Singapore

Lutron GL Ltd
15 Hoe Chiang Road
#07-03, Tower Fifteen
Singapore, 089316
TEL: +65.6220.4666
FAX: +65.6220.4333
Technical Support: 800.120.4491

©2011 LUTRON Electronics Co., Inc.
P/N 045-184 REV A 12/2012