

# Lutron® roller 100™/ roller 150™ ceiling mount chassis

English

Installation Guide (please read before installing)

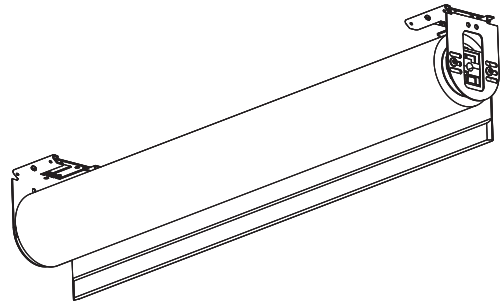

The roller 100/ roller 150 Ceiling Mount Chassis Installation Guide is a complement to the enclosed Basic Wiring and Setup Guide. The Chassis Installation Guide describes the mechanical installation. The Basic Wiring and Setup Guide describes the wiring and setup for basic function of the roller shade.

#### Tools required:

- Tape Measure
- Power Drill
- #2 Phillips Screwdriver
- 1/4 in Hex-Head Driver
- Level

#### Box Contents:

(1) Lutron roller 100/ roller 150 shade

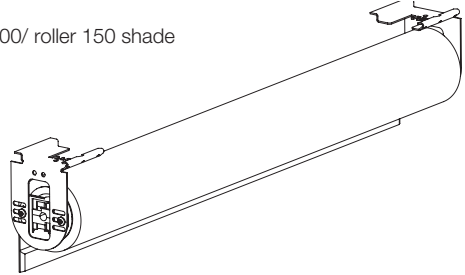

Left and right side shade brackets (attached)

(2) Ceiling sub-brackets



(8) Mounting screws  
(#8x1-3/4 in)



**CAUTION:** Risk of minor or moderate injury from falling heavy objects. Securely install the roller shade per the mounting instructions.

#### Notes:

- Lutron systems are intended for use with only Lutron hardware, controls, and power supplies.
- **Codes:** Install in accordance with all local and national electrical codes.
- **Environment:** Ambient operating temperature: 32 °F - 104 °F (0 °C - 40 °C), 0 - 90% humidity, non-condensing. Indoor use only.
- Maintain sufficient clearance between the moving shade and any object.
- Mount fixed controls and keep remote controls out of reach of children.
- Do not operate shades/drapes if there are signs of wear or damage.

## 1 Pre-drill for cable

1.1 Determine where to drill for cable access. See options below. Cable should exit from wall, ceiling or jamb on Drive side of system.

**Note:** Leave 12 to 18 in (305 to 457 mm) of cable exposed.

#### Ceiling

Drill for cable 0.5 in (13 mm) from end of system and 0.5 in (13 mm) from mounting wall.

#### Wall

Drill for cable 1.25 to 2 in (32 to 51 mm) from end of system and 2 to 2.5 in (51 to 64 mm) from top of system.

#### Jamb

Drill for cable 0.5 in (13 mm) from end of system and 0.5 in (13 mm) from mounting wall.

**Note:** Ceiling brackets are not compatible with 3-sided pocket mount applications.

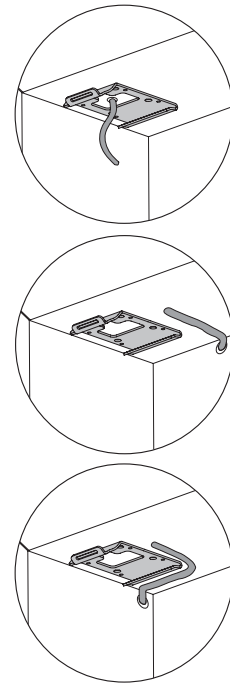

## 2 Mount the sub-brackets

2.1 Use the alignment holes to position the sub-bracket horizontally. The alignment holes line up with the outside edge of the shade tube, so the left and right bracket alignment holes should be spaced at a distance that matches the shade panel fabric width, centered on the window.

2.2 Mount sub-brackets using appropriate fasteners.

**CAUTION:** Risk of minor or moderate injury from falling heavy objects. Securely attach the sub-brackets to a structural member.

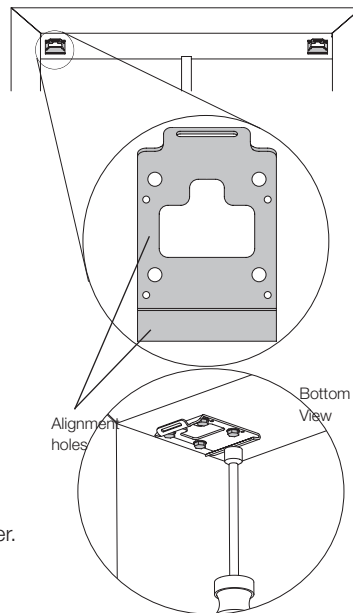

## 3 Mount the shade to sub-brackets

**NOTICE:** Shades wider than 4 ft (1.2 m) require two people to install.

3.1 Remove retaining screws from shade brackets.

**Note:** Leave protective wrapping on shade during installation.

3.2 Slide back of shade bracket into slot of sub-bracket.

3.3 Slide shade back while swinging front of shade bracket up to hook on sub-bracket.

3.4 Confirm shade bracket is fully engaged with sub-bracket.

3.5 Route cable from wall, ceiling or jamb between the shade bracket and the sub bracket. Do not pinch the cable.

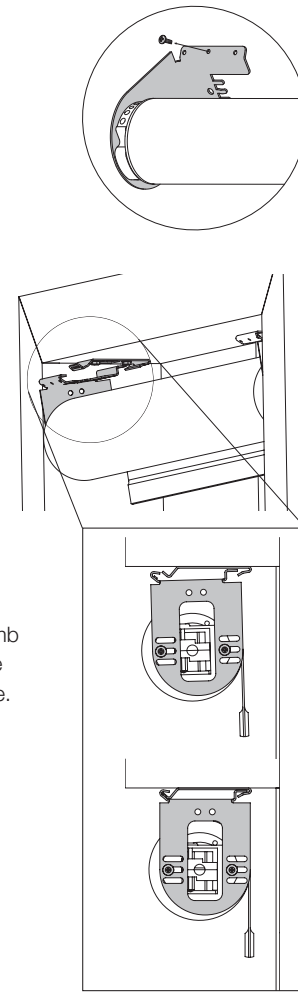

## 4 Center and secure shade

4.1 Move the shade left or right until centered on the window.

4.2 Insert and tighten retaining screws on BOTH shade brackets to secure the shade into position. Screws should be tightened down all the way.

**CAUTION:** Risk of minor or moderate injury from falling heavy objects. Ensure the shade bracket is securely attached to the sub-bracket.

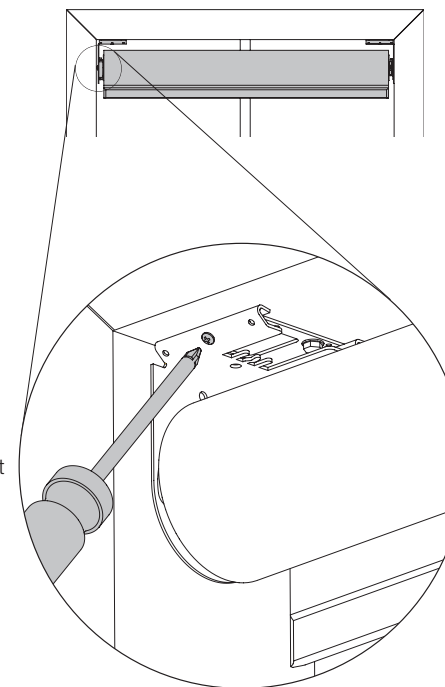

## 5 Leveling the shade

5.1 Turn leveling screw to raise or lower idler side of shade until level.

5.2 Adjust shade projection from window so that it clears any window trim or hardware when operating.

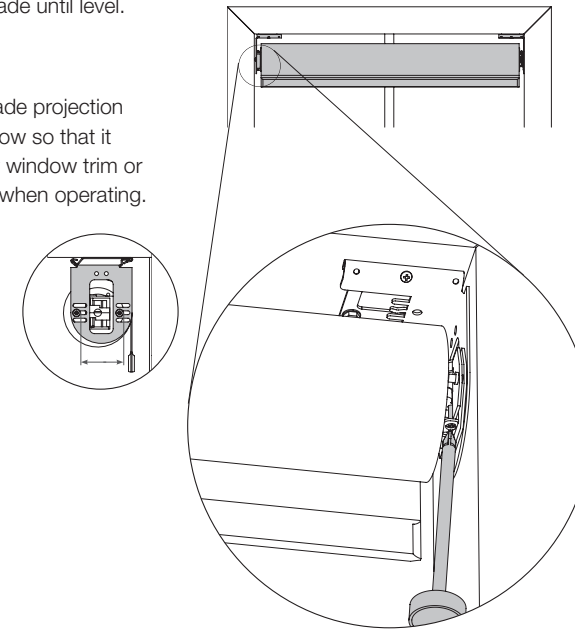

## 6 Wiring and basic setup

6.1 Refer to the Basic Wiring and Setup Guide included with the Roller Shade System for wiring instructions and setup including setting open and close limits.

## 7 Check shade for telescoping

7.1 Use the programming stylus to run the shade up and down using the adjustment buttons (↕), re-level if needed.

**Note:** Monitor fabric as it rolls up on the tube to ensure that it does not telescope excessively to one side or the other.

Slight telescoping is normal. However, if the shade is telescoping severely to one side and it is level, tap the "Close Limit Button" (■), and lower the shade all the way down using the adjustment buttons (↕). Place a piece of tape on the side of the tube that the fabric is telescoping away from, tap the "Close Limit Button" (■) once to exit. This technique is referred to as "SHIMMING". The shade will always track towards the side with the tape (shim). For more information see: [www.lutron.com/TechnicalDocumentLibrary/Apps\\_Note\\_14.pdf](http://www.lutron.com/TechnicalDocumentLibrary/Apps_Note_14.pdf)

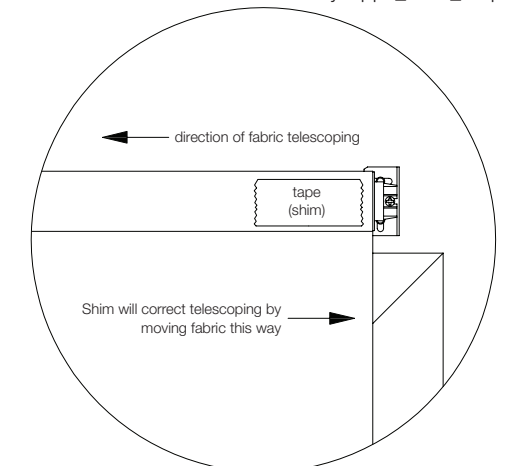

8 Troubleshooting	
Symptom	Solution
<b>Fabric is not level.</b>	Verify the brackets are mounted level
<b>Fabric is not centered over window.</b>	Verify the brackets are centered
<b>Shade does not move smoothly.</b>	Verify the shade fabric is not obstructed by the side channels or any other object
<b>Shade will not move to full open or full close</b>	Verify that open and close limits are set correctly Verify that shade fabric is not obstructed or caught on something

## Limited Warranty

### SCOPE

This limited warranty ("Warranty") covers the Lutron supplied (a) Sivoia® QS Shade System ("Sivoia® QS Shade System"), (b) Sivoia QED™ Shade System ("Sivoia QED™ Shade System"), (c) manual shade system and (d) alternating current or a/c shade system (each of the foregoing being a "System"). Customer acknowledges and agrees that use of the System constitutes acceptance of all terms and conditions of this Warranty.

### LIMITED WARRANTY

Subject to the exclusions and restrictions described below, Lutron warrants that each System will be free from manufacturing defects from the date of shipment by Lutron for a period of (a) one year as to the wall controls, interfaces and system accessories of the Sivoia QS Shade System ("External Sivoia QS Components") and (b) eight years as to the other Systems and the Roller Shade EDU, shade fabric and shade hardware of the Sivoia QS Shade System. If any manufacturing defect exists in the External Sivoia QS Components, so long as Customer promptly notifies Lutron of the defect within the one year warranty period and, if requested by Lutron, returns the defective part(s), Lutron will, at its option, either repair the defective part(s) or provide comparable replacement part(s). If any manufacturing defect exists in any of the components of a System other than the External Sivoia QS Components, so long as Customer promptly notifies Lutron of the defect within the eight year warranty period and, if requested by Lutron, returns the defective part(s), Lutron will, at its option, either repair the defective part(s) or issue a credit to the Customer against the purchase price of comparable replacement part(s) purchased from Lutron as provided below:

Number of years from date of shipment	Percentage of cost of replacement parts credited by Lutron
Up to 5	100%
More than 5 but not more than 8	50%
More than 8	0%

Replacement parts for the System provided by Lutron or, at its sole discretion, an approved vendor may be new, used, repaired, reconditioned, and/or made by a different manufacturer.

### EXCLUSIONS AND RESTRICTIONS

This Warranty will be void, and Lutron and its suppliers will have no responsibility under this Warranty, if Lutron or its representatives cannot access any components of the System to inspect, diagnose problems with or repair the System or any of its components as a result of concealment or inaccessibility of such components within a building structure. This Warranty does not cover, and Lutron and its suppliers are not responsible for:

- Damage, malfunction or inoperability diagnosed by Lutron or a Lutron approved third party as caused by normal wear and tear, abuse, misuse, incorrect installation, neglect, accident, interference or environmental factors, such as (a) use of incorrect line voltages fuses or circuit breakers; (b) failure to install, maintain and operate the System pursuant to the operating instructions provided by Lutron and the applicable provisions of the National Electrical Code and of the Safety Standards of Underwriter's Laboratories; (c) use of incompatible devices or accessories; (d) improper or insufficient ventilation; (e) unauthorized repairs or adjustments or alterations; (f) vandalism; (g) an act of God, such as fire, lightning, flooding, tornado, earthquake, hurricane or other problems beyond Lutron's control; or (h) direct exposure to corrosive materials.
- On-site labor costs to diagnose issues with, and remove, repair, replace, adjust, reinstall and/or reprogram the System or any of its components.
- Components and equipment external to the System, such as, non-Lutron lighting and automation systems; building wiring audiovisual equipment; and non-Lutron time clocks, photosensors and motion detectors.
- The cost of repairing or replacing other property that is damaged when any System does not work properly, even if the damage was caused by the System.

**THIS WARRANTY IS IN LIEU OF ALL OTHER EXPRESS WARRANTIES. ALL IMPLIED WARRANTIES, INCLUDING THE IMPLIED WARRANTIES OF MERCHANTABILITY AND OF FITNESS FOR A PARTICULAR PURPOSE, ARE LIMITED TO EIGHT YEARS FROM THE DATE OF SHIPMENT, EXCEPT THAT SUCH IMPLIED WARRANTIES ARE LIMITED TO ONE YEAR FROM THE DATE OF SHIPMENT AS TO THE EXTERNAL SIVOIA QS COMPONENTS. NO LUTRON AGENT, EMPLOYEE OR REPRESENTATIVE HAS ANY AUTHORITY TO BIND LUTRON TO ANY AFFIRMATION, REPRESENTATION OR WARRANTY CONCERNING THE SYSTEMS. UNLESS AN AFFIRMATION, REPRESENTATION OR WARRANTY MADE BY AN AGENT, EMPLOYEE OR REPRESENTATIVE IS SPECIFICALLY INCLUDED HEREIN, OR IN STANDARD**

**PRINTED MATERIALS PROVIDED BY LUTRON, IT DOES NOT FORM A PART OF THE BASIS OF ANY BARGAIN BETWEEN LUTRON AND CUSTOMER AND WILL NOT IN ANY WAY BE ENFORCEABLE BY CUSTOMER. IN NO EVENT WILL LUTRON OR ANY OTHER PARTY BE LIABLE FOR EXEMPLARY, CONSEQUENTIAL, INCIDENTAL OR SPECIAL DAMAGES (INCLUDING, BUT NOT LIMITED TO DAMAGES FOR PERSONAL INJURY, FAILURE TO MEET ANY DUTY, INCLUDING OF GOOD FAITH OR REASONABLE CARE, NEGLIGENCE, OR ANY OTHER LOSS WHATSOEVER), NOR FOR ANY REPAIR WORK UNDERTAKEN WITHOUT LUTRON'S PRIOR WRITTEN CONSENT ARISING OUT OF OR IN ANY WAY RELATED TO THE INSTALLATION, DEINSTALLATION, USE OF OR INABILITY TO USE THE SYSTEM OR OTHERWISE UNDER OR IN CONNECTION WITH ANY PROVISION OF THIS WARRANTY, EVEN IN THE EVENT OF THE FAULT, TORT (INCLUDING NEGLIGENCE), STRICT LIABILITY, BREACH OF CONTRACT OR BREACH OF WARRANTY OF LUTRON OR ANY OTHER PARTY, AND EVEN IF LUTRON OR SUCH OTHER PARTY WAS ADVISED OF THE POSSIBILITY OF SUCH DAMAGES. NOTWITHSTANDING ANY DAMAGES THAT CUSTOMER MIGHT INCUR FOR ANY REASON WHATSOEVER (INCLUDING, WITHOUT LIMITATION, ALL DIRECT DAMAGES AND ALL DAMAGES LISTED ABOVE), THE ENTIRE LIABILITY OF LUTRON AND OF ALL OTHER PARTIES UNDER THIS WARRANTY ON ANY CLAIM FOR DAMAGES ARISING OUT OF OR IN CONNECTION WITH THE MANUFACTURE, SALE, INSTALLATION, DELIVERY, USE, REPAIR, OR REPLACEMENT OF THE SYSTEM, AND CUSTOMER'S SOLE REMEDY FOR THE FOREGOING, WILL BE LIMITED TO THE AMOUNT PAID BY CUSTOMER FOR THE SYSTEM. THE FOREGOING LIMITATIONS, EXCLUSIONS AND DISCLAIMERS WILL APPLY TO THE MAXIMUM EXTENT ALLOWED BY APPLICABLE LAW, EVEN IF ANY REMEDY FAILS ITS ESSENTIAL PURPOSE. THIS WARRANTY GIVES YOU SPECIFIC LEGAL RIGHTS. YOU MAY ALSO HAVE OTHER RIGHTS WHICH VARY FROM STATE TO STATE. SOME STATES DO NOT ALLOW LIMITATIONS ON HOW LONG AN IMPLIED WARRANTY LASTS OR THE EXCLUSION OR LIMITATION OF INCIDENTAL OR CONSEQUENTIAL DAMAGES, SO THE ABOVE LIMITATIONS OR EXCLUSIONS MAY NOT APPLY TO YOU. WARRANTY CLAIMS, TECHNICAL ASSISTANCE AND WARRANTY INFORMATION.**

Contact the Lutron Technical Support Center at the numbers provided below or your local Lutron sales representative with questions concerning the installation or operation of the System or this Warranty, or to make a warranty claim. Please provide the exact model number when calling. Lutron and  are registered trademarks of Lutron Electronics Co., Inc.

### Worldwide Headquarters | USA

Lutron Electronics Co., Inc.  
7200 Suter Road  
Coopersburg, PA 18036-1299 USA  
TEL: 1.610.282.3800  
FAX: 1.610.282.3090  
Technical Support: 1.800.523.9466 or 1.610.282.6701  
Toll Free: 1.888.LUTRON1  
EMAIL: [shadinginfo@lutron.com](mailto:shadinginfo@lutron.com)  
WEB: [www.lutron.com/shadingsolutions](http://www.lutron.com/shadingsolutions)

### Europe Headquarters | United Kingdom

Lutron EA Ltd  
6 Sovereign Close  
London, E1W 3JF, UK  
TEL: +44.(0)20.7702.0657  
FAX: +44.(0)20.7480.6899  
Technical Support: +44.(0)20.7680.4481  
FREEPHONE: 0800.282.107

### Asian Headquarters | Singapore

Lutron GL Ltd  
15 Hoe Chiang Road  
#07-03, Tower Fifteen  
Singapore, 089316  
TEL: +65.6220.4666  
FAX: +65.6220.4333  
Technical Support: 800.120.4491

©2011 LUTRON Electronics Co., Inc.  
P/N 045-186 REV C 12/2012