

# myRoom™ Ethernet Network Configuration

## Installation Overview

The network architecture that forms the Local Area Network (LAN) for the myRoom™ processor and server communications of the myRoom™ guestroom control system can be adapted to an existing hotel's network infrastructure. While this can be of substantial savings in time and material when adapted to a hotel's network infrastructure, the responsibility, setup, and authority for that network falls directly under that hotel's IT administration.

When using a hotel's network infrastructure, the myRoom™ LAN must have unrestricted communication within that hotel's IT parameters. This document lists the myRoom™ LAN IT requirements and must to be given to the hotel's IT administration prior to system installation.

Timeliness of a project where myRoom™ is residing on the hotel's network is dependent on that hotel's IT planning and cooperation. The earlier the hotel IT administration is brought into the project the easier and more efficient the installation will be.

## Ethernet Overview

The myRoom™ guestroom management system requires an IEEE 802.3 Ethernet link to enable communications between myRoom™ processors as well as between myRoom™ processors and the myRoom™ server. When this Ethernet link is supplied by a customer's IT department, it must be designed and configured to meet the hotel's IT requirements and the myRoom™ LAN requirements.

## System Overview

Each facility will have its own characteristics. This document outlines the guidelines and requirements for the infrastructure to support the Lutron® myRoom™ system.

The myRoom™ Ethernet communications link follows the IEEE 802.3 Ethernet standard using a minimum cabling of Category 5 (CAT5). This copper or fiber wiring must follow the standard IEEE 802.3 Ethernet wiring rules for distance and separation.

- CAT5 maximum distance requirement: 328 ft (100 m).
- If a cable run of longer than 328 ft (100 m) is required, an ethernet switch (by others) will need to be used to extend the length.

It is possible to use an existing Ethernet infrastructure installed in the building as the myRoom™ processor communications link. When this is done, the customer, network installer, and network administrator must be aware of the myRoom™ system requirements.

The myRoom™ system uses IP any-source multicast between the myRoom™ server and processors by default. The customer-provided network must be configured to allow multicast traffic between the myRoom™ server and processors on the network.

The myRoom™ VLAN must be separate from the rest of the hotel's network systems. This includes the guest room network, point of sale systems and any public access networks.

<p><b>Job Name:</b></p> <p><b>Job Number:</b></p>	<p><b>Model Numbers:</b></p>
--	------------------------------

### System Start-Up

When the network is supplied by others, the network must be operational before the certified Lutron® service engineer arrives on-site for system start-up. The system start-up cannot be completed without reliable connectivity between the myRoom™ processors and the myRoom™ server.

The customer may be required to schedule an additional field service visit at an additional charge if start-up cannot be completed. This may occur if the network is not installed or if any networking equipment required to ensure connectivity between myRoom™ components is not operational and properly configured.

### Site and Network Access

Certified Lutron® service engineers and supporting personnel must have access to network equipment required to ensure communication between Lutron® components on the network.

If access to network equipment and/or use of network analysis tools is not permitted, the customer must ensure that qualified network support personnel are on-site and available to support the certified Lutron® service engineer during the commissioning process. Lack of support may require scheduling additional field service visits at an additional charge.

### Network Documentation

The network configuration settings of the Lutron® equipment connected to the network; such as, IP addresses, subnet masks, and gateway addresses, must be supplied to Lutron® prior to the certified Lutron® service engineer's arrival on site to commission the system.

Note: The server and each processor will need its own unique IP address for the system VLAN.

### Network Support Disclaimer

When the network is supplied by the customer's IT department, Lutron cannot be held responsible for myRoom™ system downtime that results from network downtime.

The network that is used to communicate between Lutron® myRoom™ equipment is utilized as a control and a data network. Control networks require more predictable and consistent response times. Increased traffic from corporate intranet data can greatly affect these response times.

Network reliability impacts the collection of data from the myRoom™ system. This data is used to generate reports and to assess system performance. Network reliability also impacts control functions.

Lutron® recommends that the customer employ qualified network support personnel that will maintain the reliability and performance of the network post-occupancy.

### Network Equipment Requirements

All network equipment ports connected to the Lutron® myRoom™ processor are configured to 10/100 Mbps data speeds.

Network communications between the myRoom™ processor and the Lutron® server must not rely on wireless technology. A wired IEEE 802.3 Ethernet network is required for the myRoom™ system to function.

The myRoom™ management software uses a browser based user interface that can be used with wireless technology, IEEE 802.11 in communications to the myRoom™ server.

Physical and administrative access to network equipment should be limited to authorized personnel only.

<b>Job Name:</b>  <b>Job Number:</b>	<b>Model Numbers:</b>
--	-----------------------

## Response Time Requirements

The customer experience relies on sending messages over the hotel network. To meet the response time requirements, the hotel network must be configured to achieve the following:

- Service Level Agreement (unscheduled) of 99.99% for standard TCP packet transmission
- 3rd party Wireless Transceiver to 3rd party Server < 2 milliseconds, round trip time
- 3rd party Server to myRoom™ Server < 2 milliseconds, round trip time
- myRoom™ Server to myRoom™ Processor < 2 milliseconds, round trip time

## Standard Network Port Configuration

All network equipment that is required to enable connectivity between Lutron® equipment must have certain ports open.

*For communication between processors:*

- UDP Port Range 2055 thru 2184
  - Used for Lutron® subsystem processor communication for processors that are controlling suited rooms.

*For communication between processors and server:*

- UDP Port Range 2055 thru 2184 or TCP Port 51023 (depending on setup)

*For communication from client browser interface to server:*

- TCP Port 80 or 443.

*For communication between processors and other equipment:*

- UDP Port 2647
  - Used for Lutron® Processor Configuration and detection software (only required while performing initial commissioning or maintenance)
- UDP Port 47808 (BAC0)
  - Used for BACnet IP communication from a third-party Building Management System (only required if the myRoom™ system is integrating with a BMS through BACnet)
- Additional ports may be required for other third-party system integration as specified in their submittals

All network equipment required to enable connectivity to the Lutron® system must have all ports and protocols mentioned enabled/opened by default after a power-up to prevent system downtime after a power-cycle.

<b>Job Name:</b>	<b>Model Numbers:</b>
<b>Job Number:</b>	

### IP Multicast Configuration

Lutron® uses IP any-source multicast for system communication between myRoom™ processors and the myRoom™ server.

Each guestroom in the myRoom™ system must have its own unique multicast address. These multicast addresses are assigned to Lutron® for use with the myRoom™ system only. These multicast addresses must be determined and configured prior to the certified Lutron® service engineer's arrival on-site to commission the system.

Each assigned multicast address must have the ability to reach its assigned myRoom™ processor on the system. Every myRoom™ processor on the system will communicate to the myRoom™ server using multicast and unicast.

### IGMP (Internet Group Management Protocol)

In order to properly route multicast traffic between Layer 2 and Layer 3 devices, "IGMP snooping" needs to be enabled on all switches in both directions from the myRoom™ server to the myRoom™ processor and from the myRoom™ processor to the myRoom™ server.

The myRoom™ system multicast supports the IGMP standard versions 1, 2, and 3.

### PIM (Protocol Independent Multicast)

If routing multicast traffic between Layer 3 devices over a LAN or WAN, Protocol Independent Multicast will need to be enabled to properly route the multicast traffic. Both sparse mode and dense mode are supported.

### Configurable Processor Parameters

- Static IPv4 Address (Default - 192.168.X.X)
- Subnet Mask (Default - 255.255.255.0)
- Gateway Address (Default - 0.0.0.0)
- Multicast Address (Default - 239.X.X.X)
- BACnet port (Default - 47808)

### Processor Configuration Software

During system commissioning the multicast address of 224.0.37.42 must be configured. This multicast address will be used by the myRoom™ processor Configuration Software to setup Lutron® processors in the system. All Lutron® devices will respond to the multicast address of 224.0.37.42, and Lutron® processors will join the multicast group 224.0.37.42 using IGMP.

**Note:** The multicast address of 224.0.37.42 is only used during the initial start-up and commissioning of the system. It is also used for diagnostics if a certified Lutron® service engineer is on-site. It is not a constant requirement to have this multicast address active.

<p><b>Job Name:</b></p> <p><b>Job Number:</b></p>	<p><b>Model Numbers:</b></p>
--	------------------------------

# System Network Diagram Example

## myRoom™ Guest Room

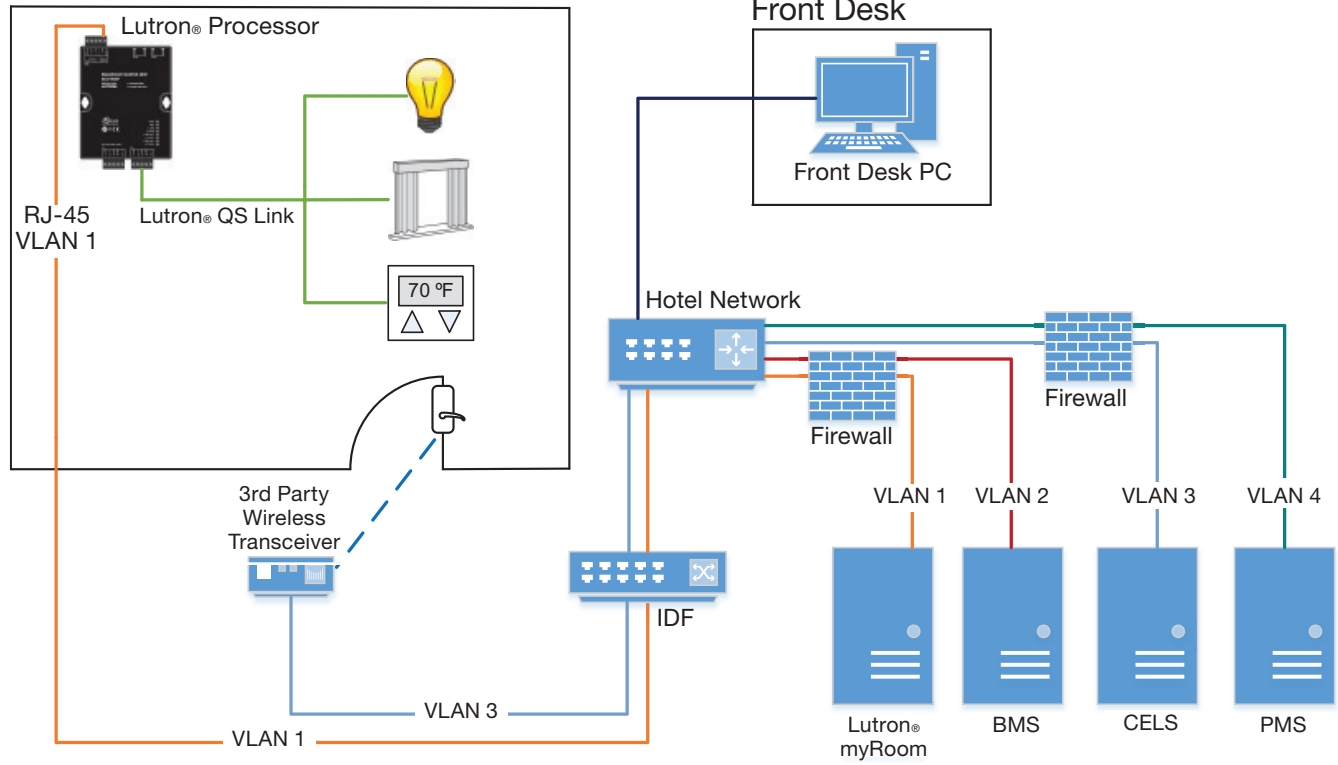

Job Name:	Model Numbers:
Job Number:	