

Sivoia® QS Wireless Cellular Shade

English

Automated shade with wireless (RF) control
Installation and Programming Guide
 (please read before installing)

Start Here

1. Review components
2. Install mounting brackets
3. Install batteries
4. Install the shade in the brackets
5. Removing the shade from the brackets
6. Programming options

1 Review components

Included:

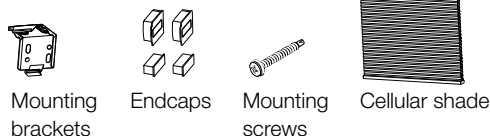

Mounting brackets Endcaps Mounting screws Cellular shade

Batteries not included



Rechargeable batteries

Tools required:

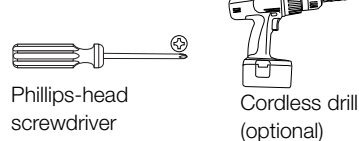

Phillips-head screwdriver Cordless drill (optional)

2 Install mounting brackets

Mount the left and right brackets 2 inches in from each end of the shade.

Note: Mount additional brackets evenly between the end brackets and clear of the cord lift.

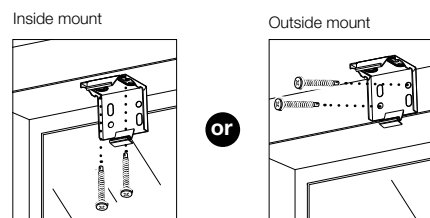

Inside mount or Outside mount

3 Install batteries

Refer to the battery holders for proper battery alignment.

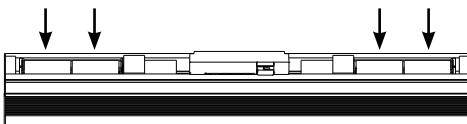

4 Install the shade in the brackets

Click the shade into place as shown below.

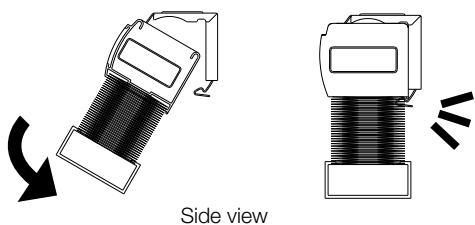

Side view

5 Removing the shade from the brackets

Use a flathead screwdriver to unclip the shade as shown.

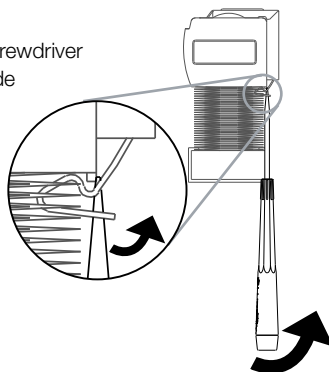

6 Programming

RadioRA® 2

- For assignment and programming without RadioRA 2 design and programming software, refer to the RadioRA 2 setup guide, available at www.lutron.com/radiora2
- Otherwise, use the RadioRA 2 Essentials or Inclusive software to assign and program your cellular shades.

HomeWorks® QS

- Use the HomeWorks QS design and programming software to assign and program your cellular shades.

Standalone

- Proceed to steps 7 and 8 to assign and program your cellular shades with standalone controls.

7 Assigning controls

7.1 Enter shade setup mode:

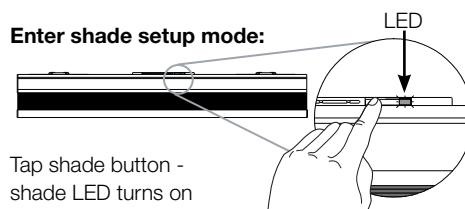

Tap shade button - shade LED turns on solid green

7.2 Assign control:

Hold "Close" (6 seconds)

Shade LED blinks for 2 seconds

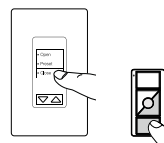

8 Set the limits

Note: Shade limits must either be set with a Pico® or with RadioRA2 or HomeWorks QS design and programming software.

8.1 Enter shade setup mode:

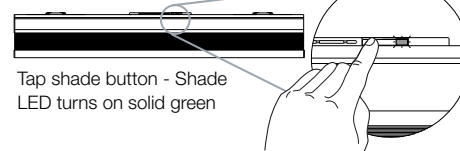

Tap shade button - Shade LED turns on solid green

8.2 Enter limit setup mode:

Hold "Open" AND "Raise" (3 seconds)

Shade LED blinks for 2 seconds, then remains on.



8.3 Adjust limits:

Press "Raise" or "Lower"

Shade LED remains on solid green.



8.4 Save and exit:

To set the upper limit: Hold "Open" (6 seconds)

To set the lower limit: Hold "Close" (6 seconds)

Shade LED blinks for 2 seconds, then turns off.



9 Restore factory defaults (optional)

Tap 3 times, hold 3 seconds, tap 3 times.

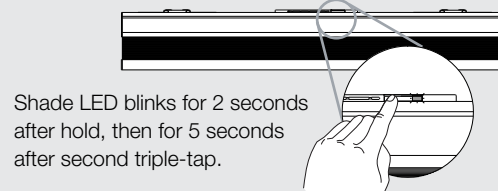

Shade LED blinks for 2 seconds after hold, then for 5 seconds after second triple-tap.

10 Troubleshooting

Symptom	Solution
Shade does not go all the way down	Fabric needs to relax (close shade for 24 hours then reset the lower limit) Reset the lower limit
Shade hangs unevenly	Ensure that fabric is not pinched in the mounting brackets

Limited warranty

Number of years from date of shipment	Percentage of cost of replacement parts credited by Lutron
Up to 5	100%
More than 5 but not more than 8	50%
More than 8	0%

For more information:
www.lutron.com/technicaldocumentlibrary/window%20systems%20warranty.pdf

Contact the Lutron Technical Support Center at the numbers provided below or your local Lutron sales representative with questions concerning the installation or operation of the System or this Warranty, or to make a warranty claim. Please provide the exact model number when calling.

Lutron, the Sunburst logo, Sivoia, RadioRA, HomeWorks, and Pico are registered trademarks of Lutron Electronics Co., Inc.

Worldwide Headquarters | USA

Lutron Electronics Co., Inc.
 7200 Suter Road
 Coopersburg, PA 18036-1299
 USA
 TEL: 1.610.282.3800
 FAX: 1.610.282.3090
 Technical Support:
 1.800.523.9466 or
 1.610.282.6701
 Toll Free: 1.888.LUTRON
 EMAIL: shadinginfo@lutron.com
 WEB: www.lutron.com/shadingsolutions

Europe Headquarters | United Kingdom

Lutron EA Ltd
 6 Sovereign Close
 London, E1W 3JF, UK
 TEL: +44.(0)20.7702.0657
 FAX: +44.(0)20.7480.6899
 Technical Support: +44.(0)20.7480.6899
 FREEPHONE: 0800.282.107

Asian Headquarters | Singapore

Lutron GL Ltd
 15 Hoe Chiang Road
 #07-03
 Singapore, 089316
 TEL: +65.6220.4666
 FAX: +65.6220.4333
 Technical Support: 800.120.4491

©2011 LUTRON Electronics Co., Inc.
 P/N 045-355 REV. A