



Sivoia QED™
Technical
Reference
Guide

rev. D



table of contents

INTRODUCTION

introduction system design benefits	a
notes	b

ELECTRICAL COMPONENTS

roller shade electrical components	1
notes	1.1
electrical electronic drive unit	1.2
electrical keypad faceplate styles	1.3
electrical keypad button layouts	1.4
electrical keypad button layouts	1.5
electrical contact closure input board	1.6
electrical external keypad power supply	1.6
electrical hand-held infrared remotes	1.7
electrical transformer panel	1.8
electrical individual transformers	1.9
electrical optional infrared receivers	1.10
electrical integration accessories	1.10
electrical integration accessories	1.11

MECHANICAL COMPONENTS

roller shade mechanical components	2
notes	2.1
mechanical fascia and top/back cover	2.2
mechanical pocket	2.2
mechanical flap and hanger	2.3
mechanical side channels and sill angles	2.3
mechanical hembars	2.3
mechanical roller 64 brackets	2.4
mechanical roller 100 jamb brackets	2.4
mechanical roller 100 ceiling brackets	2.5
mechanical roller 100 wall brackets	2.5
mechanical roller 100 dual-mounted	2.6
mechanical roller 225	2.6
mechanical roller 100	
corner installations	2.7
mechanical system dimensions	2.8
mechanical in-line coupling	2.9

WIRING

wiring	3
notes	3.1
prewire roller 64	3.2
prewire roller 100 wall and ceiling mount	3.3
prewire roller 100 jamb and fascia/top-back cover	3.4
prewire roller 100 recess pocket	3.5
prewire roller 100 dual-mounted	3.6
prewire roller 225	3.7
single EDU plug-in transformer	3.8
transformer panel overview	3.9
transformer panel home-run wiring	3.10
transformer panel with communications link	3.11
transformer panel wire specifications	3.12
transformer panel detail	3.13
multiple EDUs individual transformers overview	3.14
multiple EDUs individual transformers detail	3.15

INTEGRATION

integration	4
notes	4.1
HomeWorks® overview	4.2
HomeWorks® HWI-Q96 SOLos™ detail	4.3
GRAFIK® 3000 overview	4.4
GRAFIK® 3000 detail	4.5
GRAFIK® 3000 multiple	
SG-SVC controls	4.6
GRAFIK® 4000 overview	4.7
GRAFIK® 4000 detail	4.8
GRAFIK® 5000/6000/7000 overview	4.9
RadioRA® overview	4.10
RadioTouch™ overview	4.11

DRAPERY

drapery track systems	5
notes	5.1
drapery track systems introduction	5.2
drapery track systems straight track configurations	5.2
drapery track systems straight track configurations	5.3
drapery track systems straight track capacity	5.3
drapery track systems maximum fabric weight capacities for straight tracks	5.3
drapery track systems curved track capacity	5.4
drapery track systems mounting hardware	5.4
drapery track systems mounting hardware	5.5
drapery track systems mounting hardware	5.6
drapery track systems mounting hardware	5.7
drapery track systems measuring	5.8
drapery track systems hanging fabric	5.9
drapery track systems wiring	5.10
drapery track systems system dimensions	5.11
drapery track systems system dimensions	5.12
drapery track systems system dimensions	5.13
drapery track systems components	5.14
notes	5.15

ROMAN SHADES

Roman shades	6
notes	6.1
Roman shades system overview	6.2
Roman shades components	6.2
Roman shades dimensions	6.3
Roman shades wiring	6.4
notes	6.5

TROUBLESHOOTING

troubleshooting	7
notes	7.1
troubleshooting	7.2
troubleshooting	7.3

Sivoia QED™ | system design benefits

Sivoia QED (Quiet Electronic Drive), a low-voltage shading system, utilizes a nearly silent electronic drive unit. The control options for Sivoia QED include various styles of intuitive wall-mounted keypad and handheld remote controls to suit any need.

Simple System Design: Sivoia QED shades or draperies can be grouped together without the use of external "group controls".

Ultra Quiet Operation: Shades move in near silence. They are sound-rated at 44 dBA at 3 feet.

Maximize Window Coverage: Sivoia QED provides the smallest possible light gaps, 3/4 inch, between the shade fabric and the window frame.

Precise Movement: Shades move smoothly, in perfect unison, and with exact alignment.

New or existing spaces: Sivoia QED can be easily installed in any new construction or retrofit application.

Intuitive Control Design: Easy-to-Read and Easy-to-Use controls are immediately understood.

Convenience: Simplify your life by touching one button to open or close multiple, tall, and hard-to-reach shades.

Programmable Stop Points: The Sivoia QED electronic drive unit (EDU) optimizes shade and drapery adjustment by offering programmable stop points. This means the drive unit will track the position of the shade or drapery and be able to adjust it to predetermined locations at the touch of a button.

Reliability: Lutron Electronics has been the world leader in the lighting control industry and the designer's choice for over 40 years.

Sivoia QED™ | one system does it all

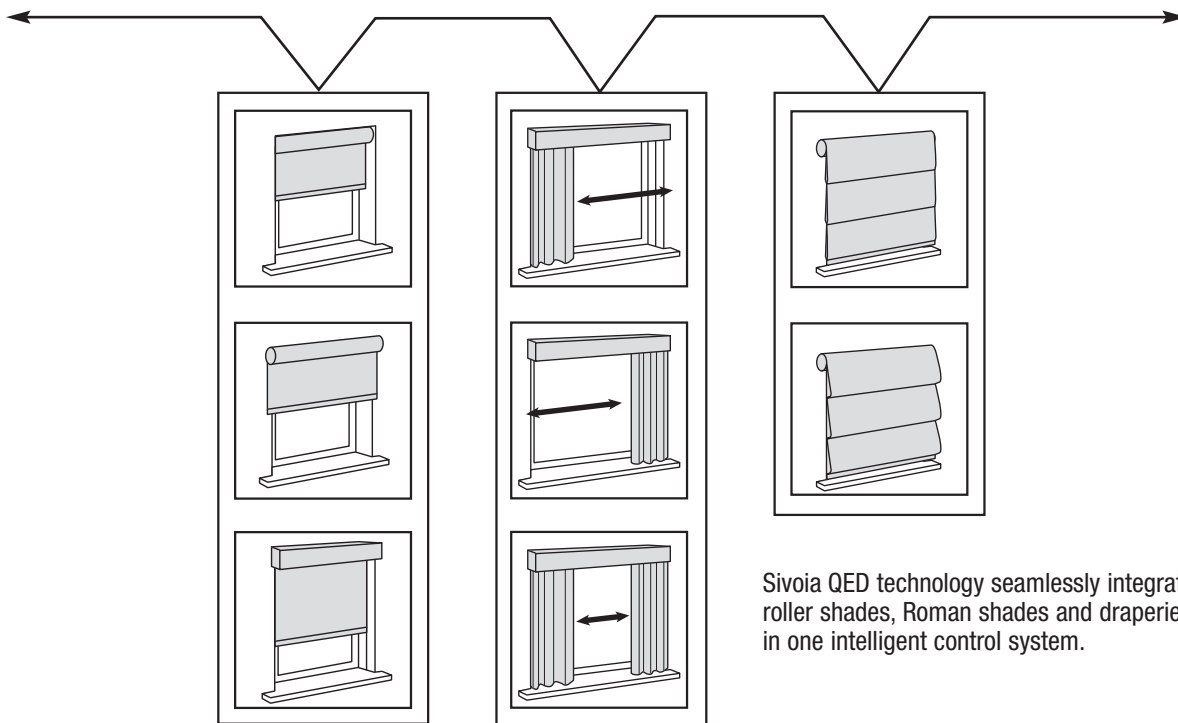

Sivoia QED technology seamlessly integrates roller shades, Roman shades and draperies in one intelligent control system.

1 | roller shade electrical components

electrical | electronic drive unit

- Ultra-Quiet operation: will not exceed 44dBA measured 3 feet from the EDU.
- Smooth, silent starts and stops.
- Integrates with Lutron Lighting control systems and other a/v equipment.
- Integrates with most outside systems such as home security or time clocks, without the use of external group controls or relay systems.
- Provides ten year power failure memory.
- Monitors shade position at all times.
- 24 VAC low-voltage power allows Sivoia QED to be installed by low-voltage contractors.
- Shades smoothly move in unison and stop in exact alignment within $\pm 1/8$ " accuracy.
- Optional infrared system provides easy, convenient control from anywhere in the room.

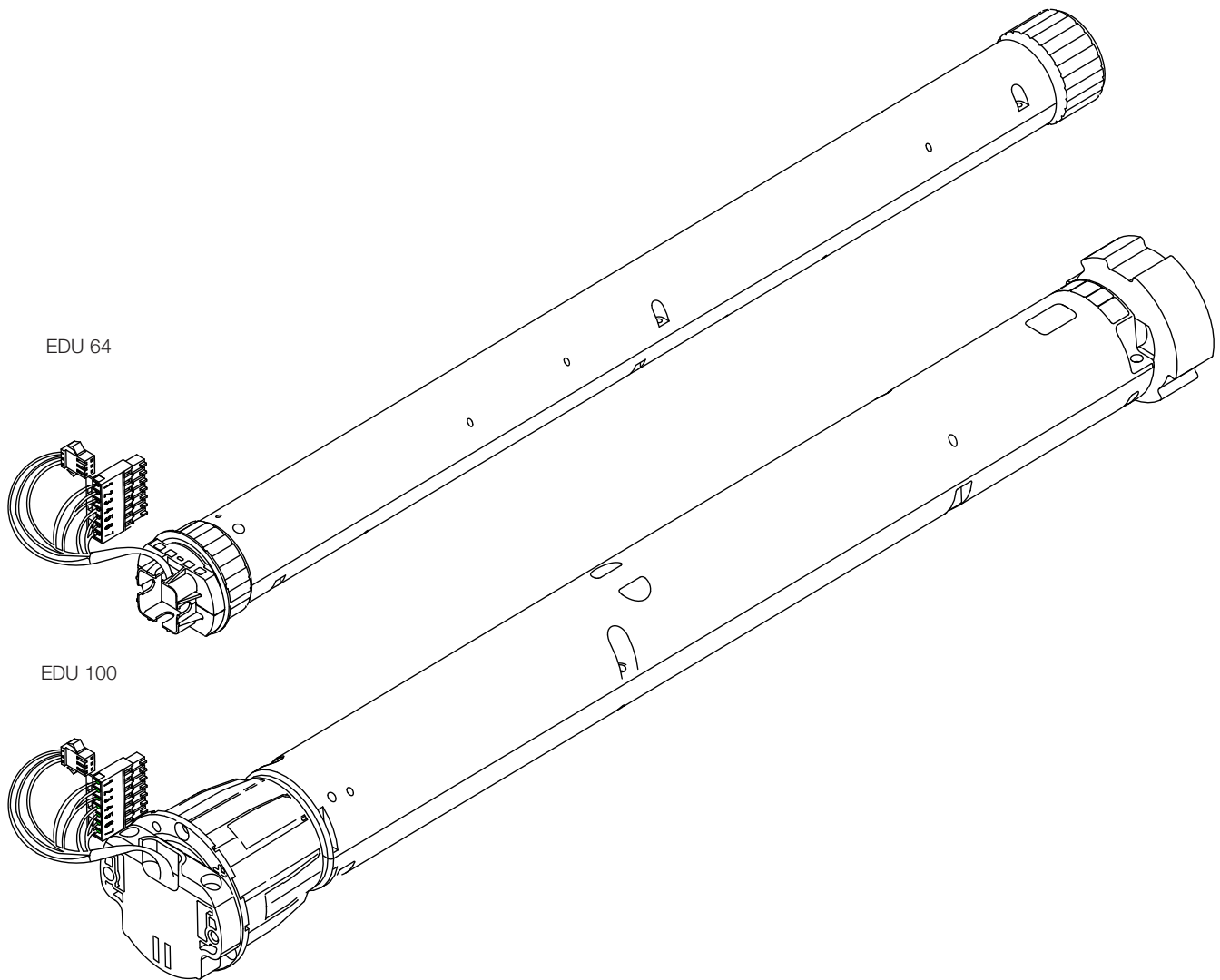

ELECTRICAL COMPONENTS

electrical | keypad faceplate styles

Architectural

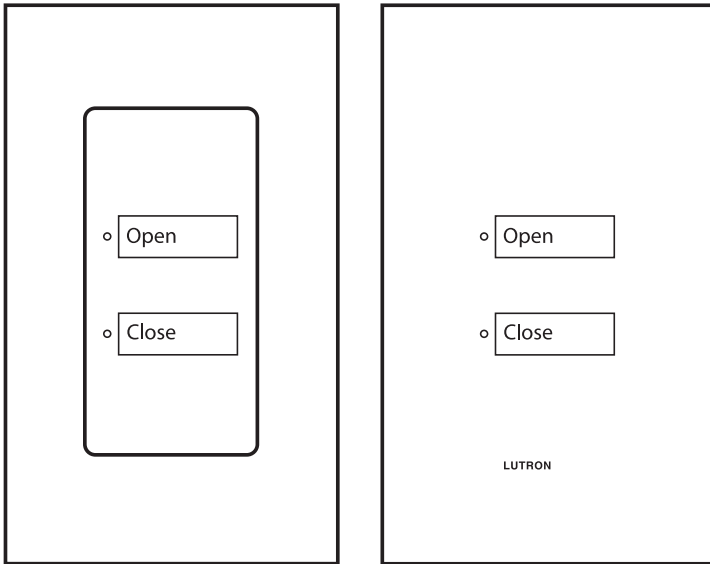

- available in insert and non-insert models
- sharp outside corners and beveled outside edges
- available in matte plastic colors and metal finishes
- product dimensions
W: 2.75"
H: 4.56"
D: 1.13"

Designer

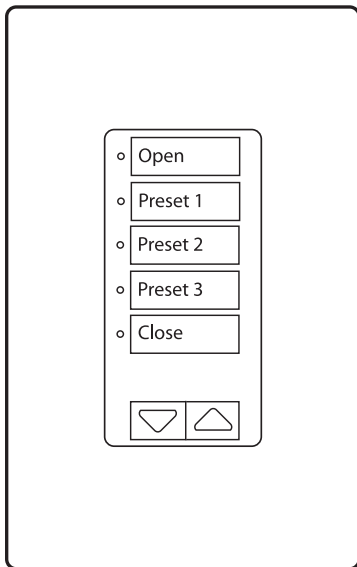

- available in insert models only
- standard “decorator” opening
- outside corners of wallplate are rounded
- available in gloss and satin finishes
- product dimensions
W: 2.94"
H: 4.69"
D: 1.13"

For a full presentation of colors, finishes, and keypad styles, please visit www.lutron.com or order the colors of Lutron brochure, P/N 367-949.

electrical keypad button layouts

All keypads control either a single EDU or a group of EDU's operating together. They require a wallbox for single or multi-gang installation.

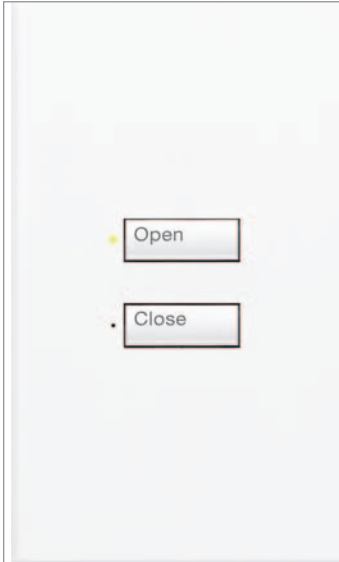

SVQ-2W-
Full open, full close



SVQ-3W-
Full open, full close, one preset



SVQ-2WRL-
Full open, full close, raise and lower



SVQ-3WRL-
Full open, full close, one preset, and raise and lower

electrical | keypad button layouts

ELECTRICAL COMPONENTS



SVQ-4WRL-IR-
Full open, full close, two presets, infrared reception, and raise and lower

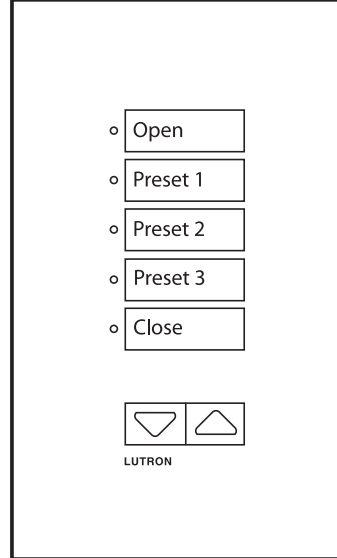

SVQ-5WRL-
Full open, three presets, full close, and raise and lower

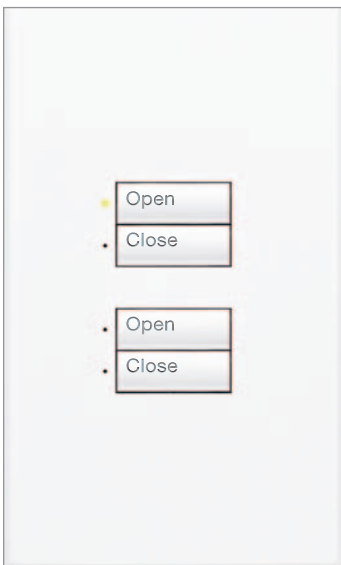

SVQ-2WD-
Full open and full close for two separate groups

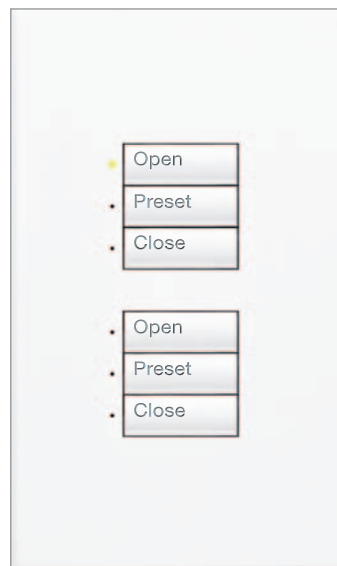

SVQ-3WD-
Full open, full close, and one preset for two separate groups

electrical | contact closure input board

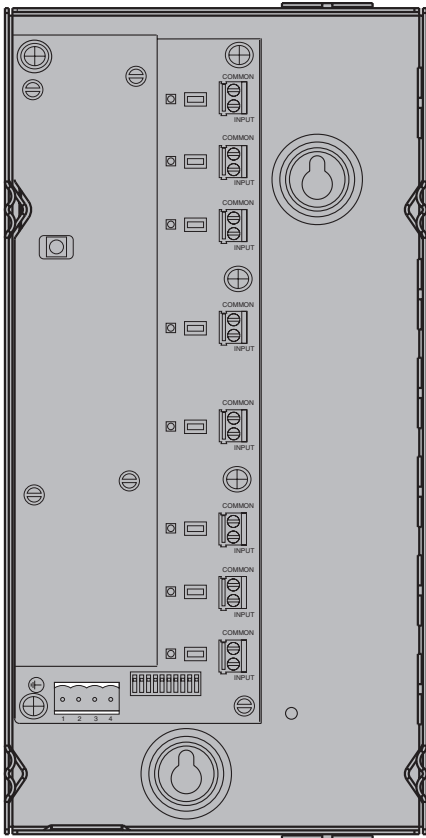

SVQ-CCI-8

- Receives eight contact closure inputs and sets presets, programs EDUs, etc.
- Utilizes low-voltage, dry contact closure inputs to interface with non-Lutron A/V equipment.
- LEDs provide feedback and receives IR commands.
- Receives power and communication on 4-wire QED communication bus.
- Ships in enclosure, ready for mounting.
- Dimensions for enclosure
W: 5.25" (5.75" with cover)
H: 10.25" (10.75" with cover)
D: 2.00"
- Terminal Blocks Accomodate 14-22 AWG wire.
- Can be configured to operate 1, 2, or 4 groups.

ELECTRICAL COMPONENTS

electrical | external keypad power supply

GRX-12VDC

The number of keypads and CCIs in a Sivoia QED system is not to exceed the number of EDUs unless an external keypad power supply is used.

The GRX-12VDC can be used to power up to four additional keypads or CCIs beyond the number of EDUs in the system. For more, please see the app note on www.lutron.com.

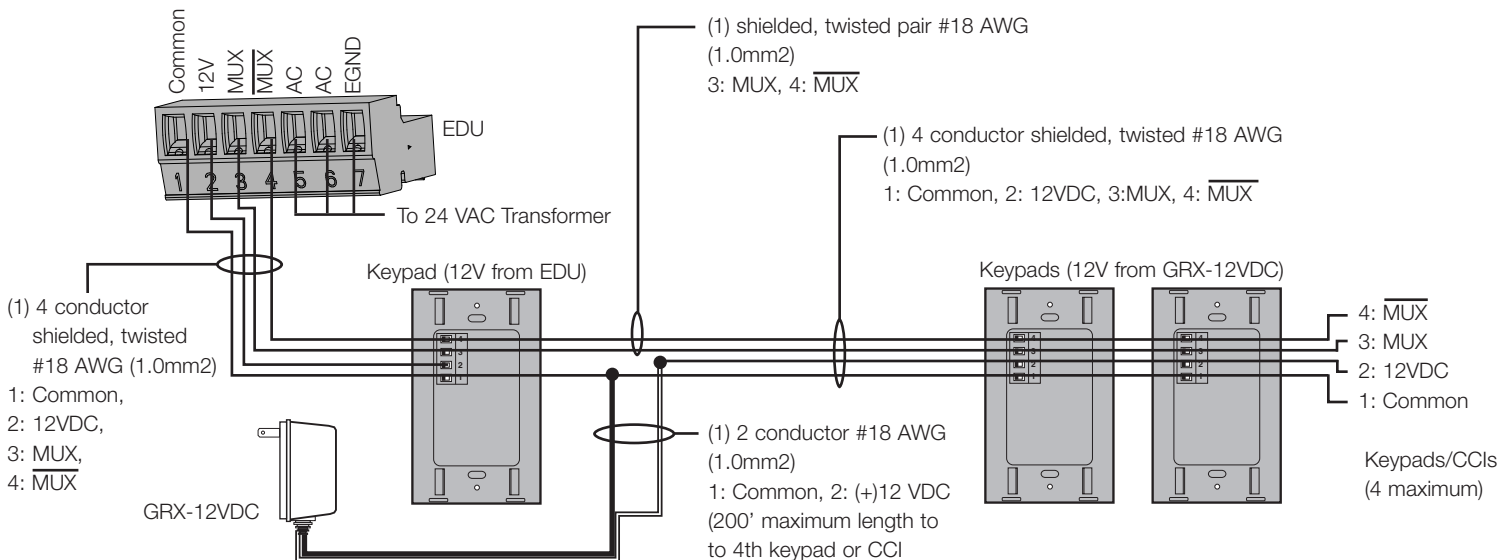

electrical | hand-held infrared remotes

Sivoia QED remotes can control one EDU or a group of EDUs acting together. They ship with AAA alkaline batteries. Use only one infrared receiver per room.

ELECTRICAL COMPONENTS

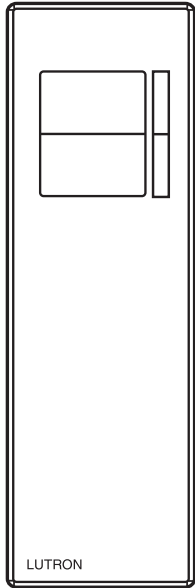

SVQ-OCIT-WH
Full open, full close and fine-tune raise and lower

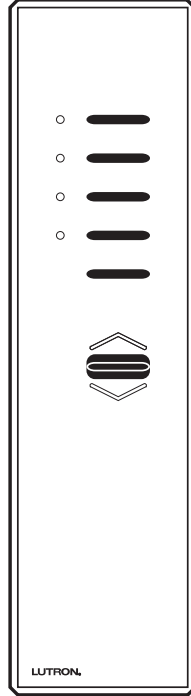

SVQ-3PIT-WH
Full open, three presets, full close and fine-tune raise and lower

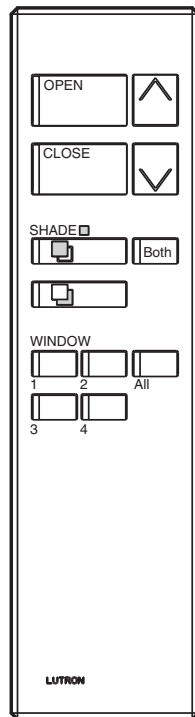

SVQ-4GD-OCIT-WH
Control individual EDUs or up to four groups of EDUs. Ideal for dual-mounted applications. (see page 2.6)

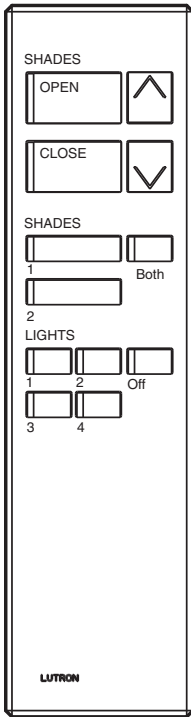

SVQ-4S2G-IT-WH
Control both Sivoia QED EDUs and Lutron lighting control systems. Ideal for home theater or conference room applications.

electrical | transformer panel

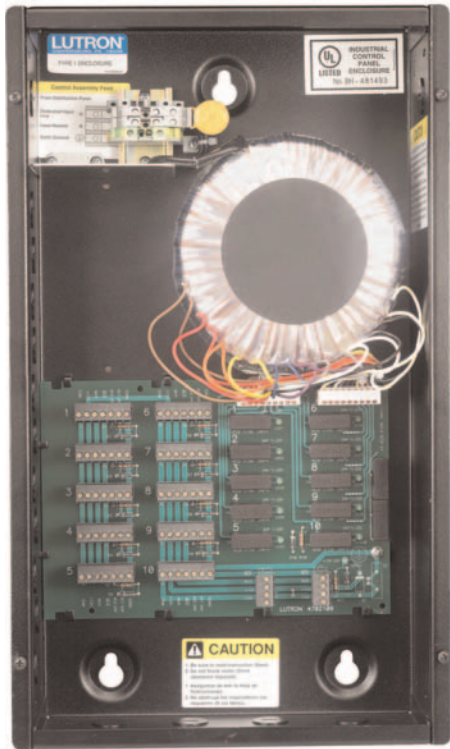

SVQ-10-PNL

Simplify the wiring and organize installations that require multiple transformers. The power panel consists of a 10-output transformer, 10 fuses and a wire landing board.

Each panel has 10-7 pin connectors for EDUs, each connector is supplied with power for an individual EDU. The panel contains a bus that connects the four communication link wires from each EDU together. It is recommended to home run both EDU and keypad wiring to the power panel.

Note: Maximum feed breaker size of 30 Amps. Each terminal block will accept one 10-18 AWG wire. Power panels must be grounded for safe operation and installed by a licensed electrician adhering to all local and national codes.

Please see the chart on page 3.12 for specific gauges and limitations.

ELECTRICAL COMPONENTS

Typical components for a Sivoia QED roller shade system (not shown to scale)

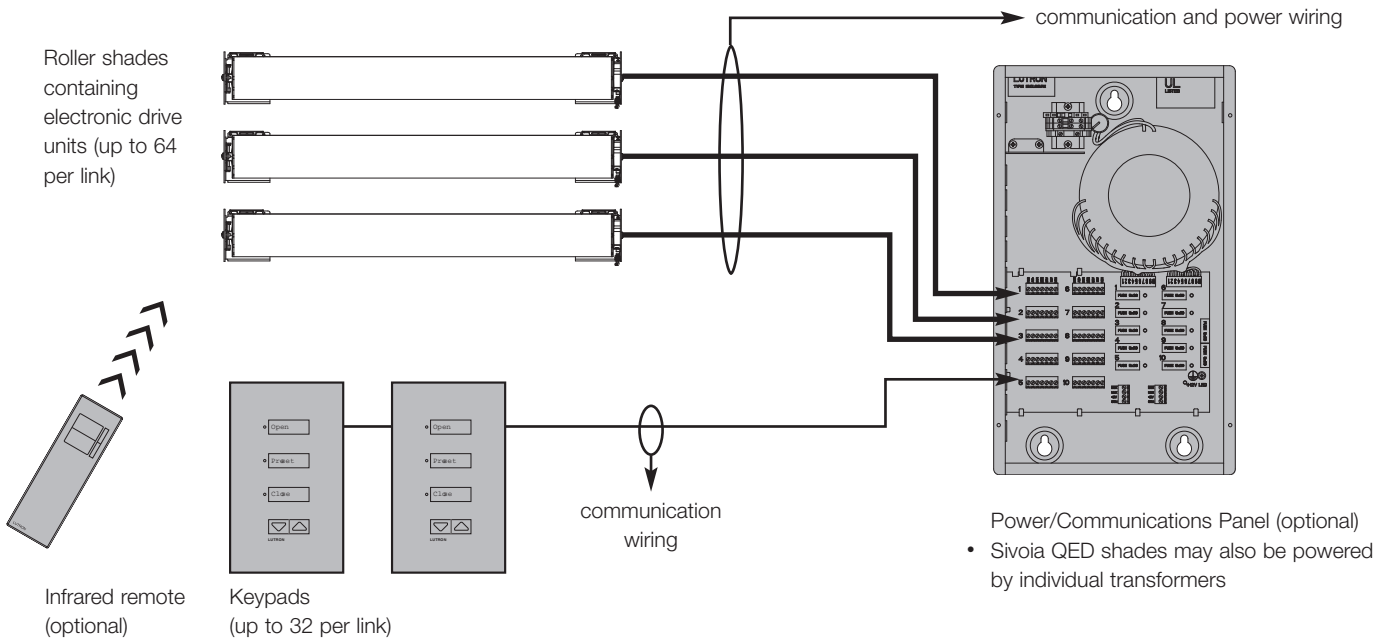

Note: CCI (Contact Closure Input) panels are available to connect to outside systems such as BMS (Building Management Systems) or touchscreen systems. See page 1.6

electrical | individual transformers

Determining which transformer to use depends upon the size of the shade the EDU needs to operate. For up to 50 square feet of fabric, the 50VA transformer is sufficient. For Sivoia QED treatments up to 225 square feet, either of the 100VA transformers can be used.

Note: There is no paralleling of transformer wiring. One transformer may only power one EDU. All transformers must be earth-grounded.

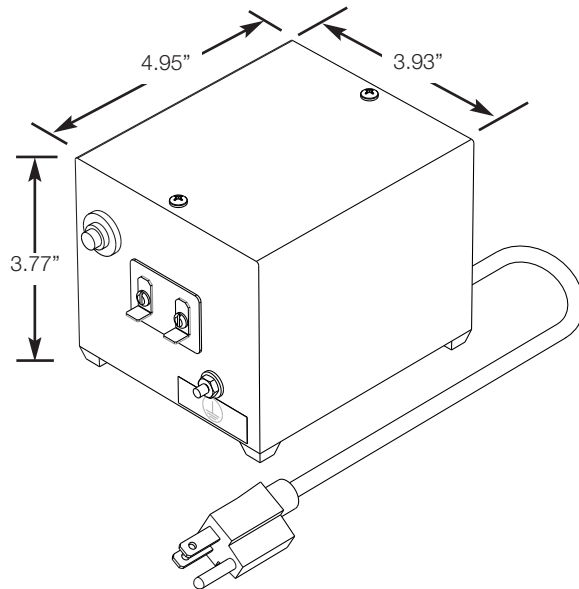
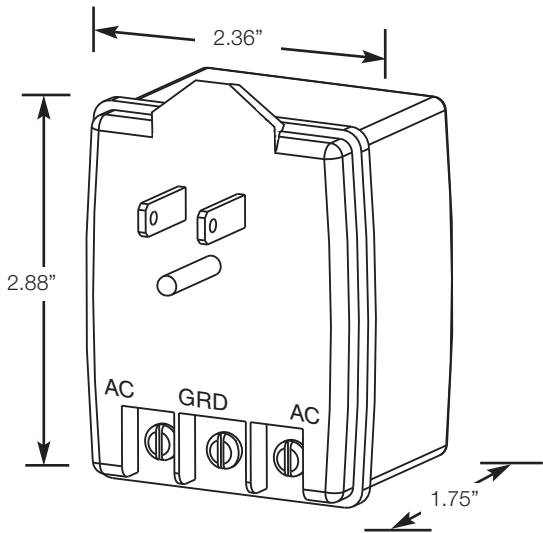

SV-50SF-PI
50VA plug-in transformer for up to 50 square feet of fabric.

SV-100SF-PI
100VA plug-in transformer for up to 225 square feet of fabric.

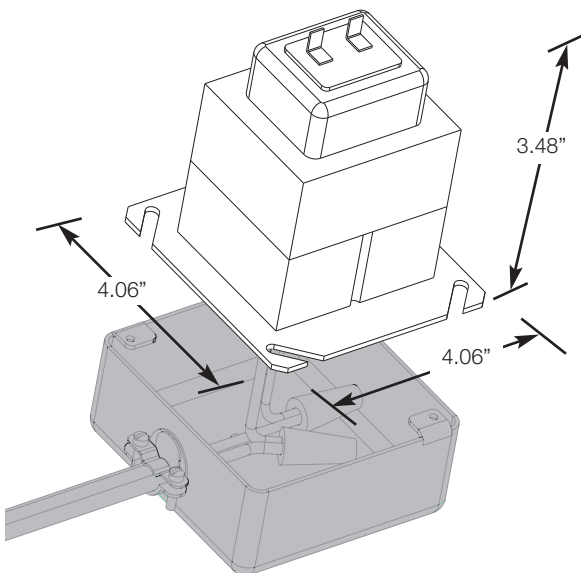

SV-100SF-JBOX
100VA junction-box mount transformer for up to 225 square feet of fabric.

TRANSFORMER CAPACITY

TYPE	CURRENT PER TRANSFORMER	TRANSFORMERS PER 15A CIRCUIT
SV-50SF-PI 44	.45A	36
SV-100SF-PI 23	.85A	17
SV-100SF-JBOX 23	.85A	17
SVQ-10-PNL* 2 PANELS	8A/PANEL	1 PANEL

*Ten EDUs per transformer panel, each EDU must be wired to a dedicated transformer

electrical | optional infrared receivers

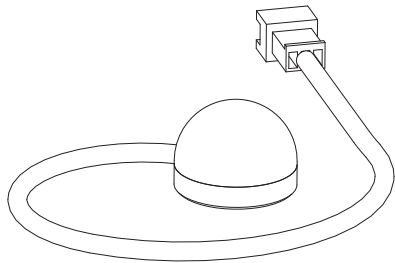

Any Sivoia QED drive has built-in infrared capability simply plug in a remote infrared receiver. It is a small 1.0" wide dome connected to the EDU by a thin 22.0" cable. Extensions of ten-foot lengths are available if the layout requires the receiver eye to be located further from the EDU. Unobtrusive mounting clips and adhesive tape are also provided.

SV-IR

Infrared remote eye, available in white and royal plum

electrical | integration accessories

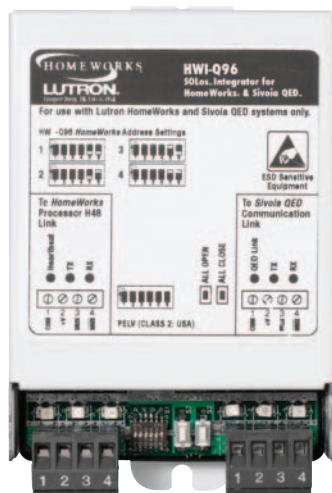

**HomeWorks® Whole-Home Lighting Control System
HWI-Q96 SOLos™ integrator**

- This low-voltage component provides two-way communication between HomeWorks and Sivoia QED systems
- Can be placed in any HomeWorks HWI-LV-17, HWI-LV-24, or HWI-LV-32 enclosures and is compatible with 4 series and 8 series HomeWorks processors
- Operate all EDUs, groups of EDUs, or single EDUs from HomeWorks Keypads or RS-232 port on HWI processor.
- For wiring information, see page 4.2

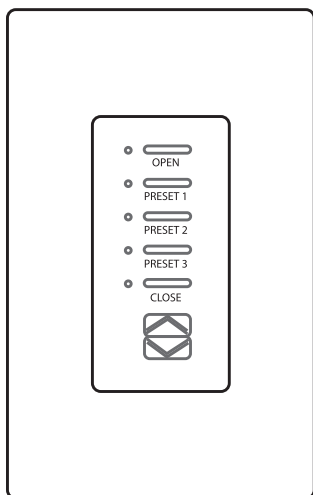

**RadioRA® Whole-Home Lighting Control System
RA-SVC**

- Receives signal from RadioRA control system and operates all EDUs on the communication link.
- Must be installed within 30 feet of signal repeater.
- For wiring information, see page 4.11

ELECTRICAL COMPONENTS

electrical | integration accessories

ELECTRICAL COMPONENTS

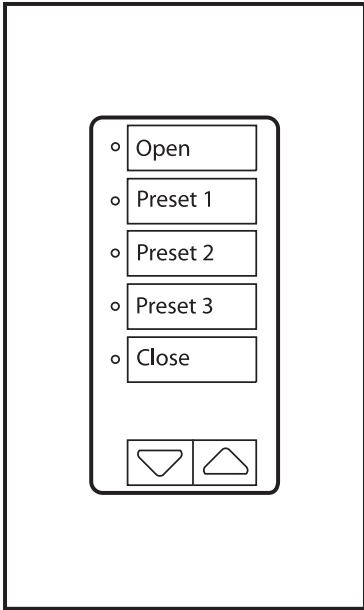

**GRAFIK 3000/4000 Lighting Control Systems
SG-SVC**

- Provides two-way communication between Sivoia QED and GRAFIK 3000 or GRAFIK 4000 lighting control system.
- Allow one zone on the Grafik Eye main unit for each SG-SVC.
- Does not occupy a GRX main unit address or accessory control address.
- Operates all Sivoia QED EDUs on the communication link.
- Available in decorator and architectural insert styles.
- For wiring information, see page 4.4

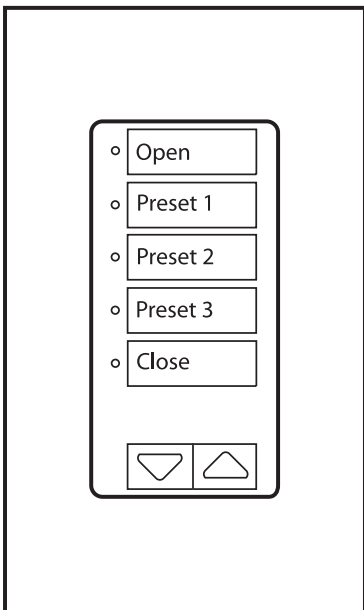

**GRAFIK 5000/6000/7000 Lighting Control Systems
SO-SVC**

- Provides two-way communication between Sivoia QED and GRAFIK 5000, 6000 or 7000 lighting control system.
- Occupies one address on wallstation link.
- Operates all QED EDUs on the communication link.
- Available in decorator and architectural insert styles.
- For wiring information, see page 4.9

2 | roller shade mechanical components

mechanical | fascia and top/back cover

A two-piece enclosure system designed to conceal the drive system and offer easy access for maintenance. Some systems offer a curved fascia as well.

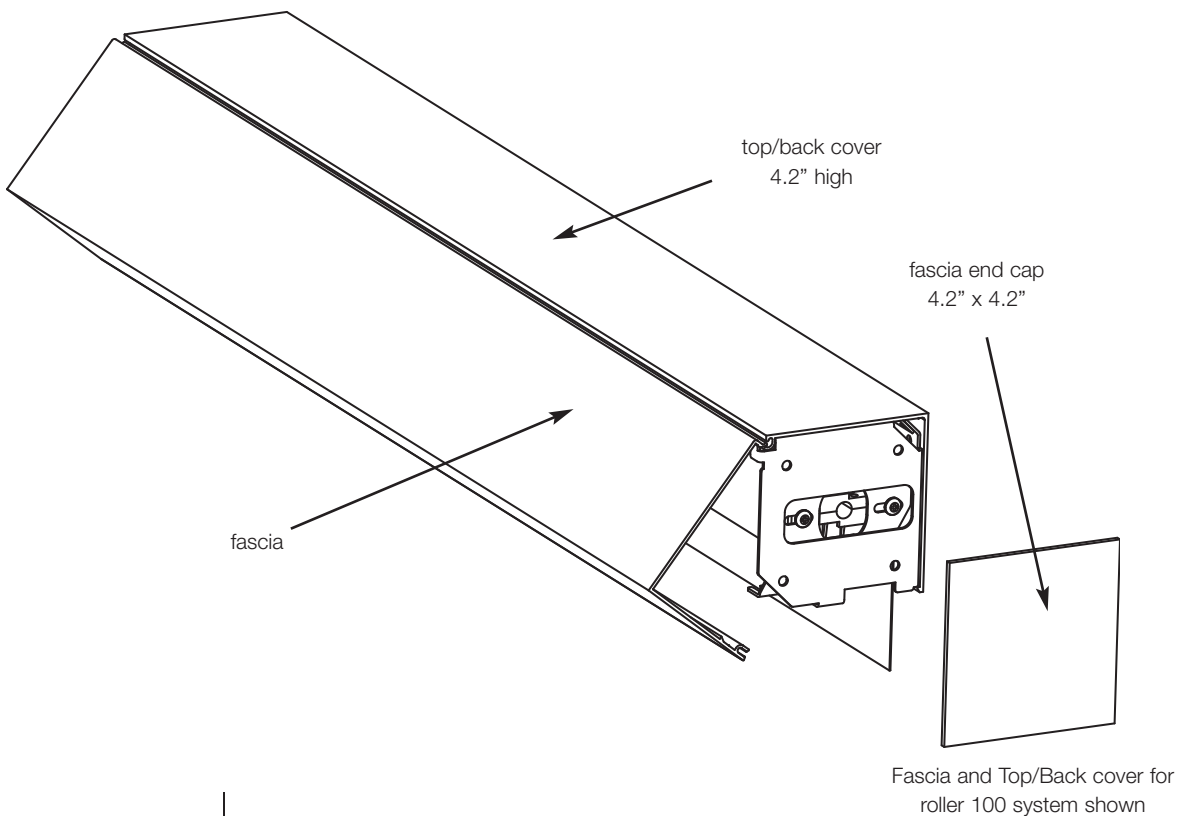

mechanical | pocket

A one-piece metal enclosure for wall, inside or recessed installation. The width of the pocket is equal to the bracket-to-bracket dimension. The pocket is approximately 1 1/2" wider than the fabric panel width. See recommended wire dressing for the roller 100 pocket to left.

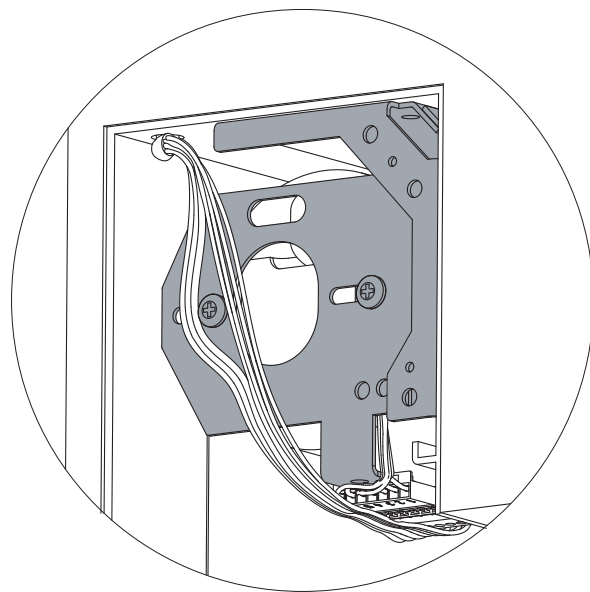
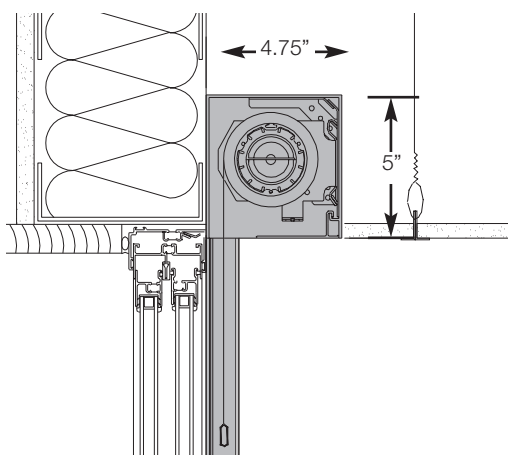

MECHANICAL COMPONENTS

mechanical | flap and hanger

A simple two-piece structure designed to conceal the roller system from view in a recessed ceiling installation. The flap is removable for maintenance access.

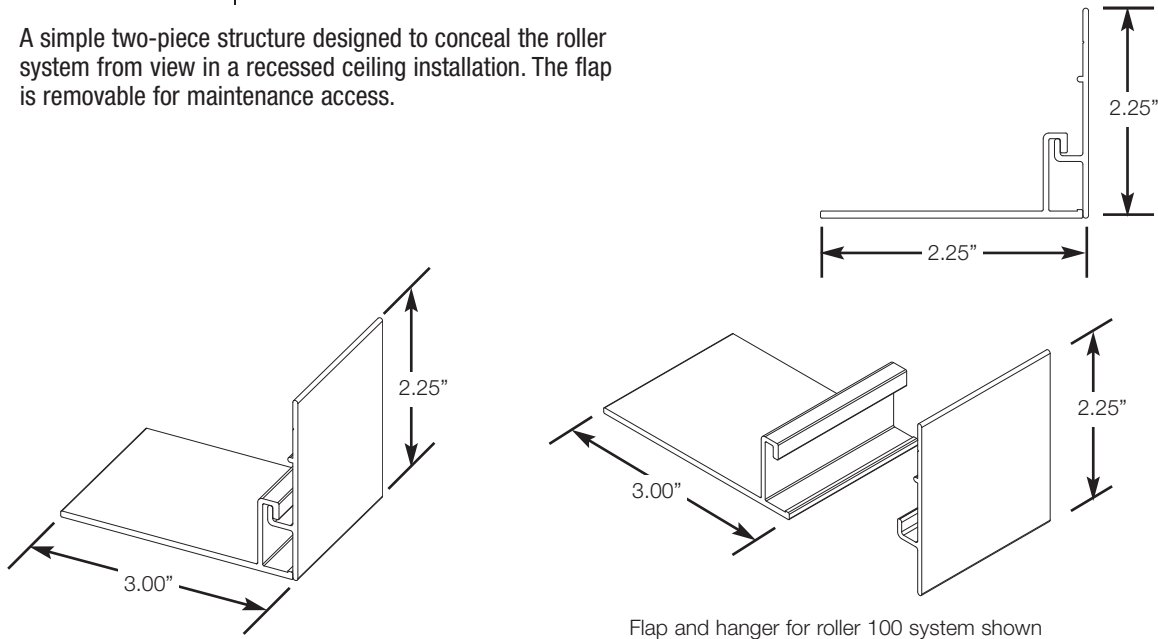

mechanical | side channels and sill angles

To provide a blackout installation, these framing lineals provide a light seal along the three edges of the fabric as it lowers in the window. The side channels are available in a 2 1/2" width and attach directly to the pocket. A wool-pile brush ensures light seal. The sill angle fits along the sill where the hembar stops. Minimal caulking may be required if the window sill surface is not smooth and level.

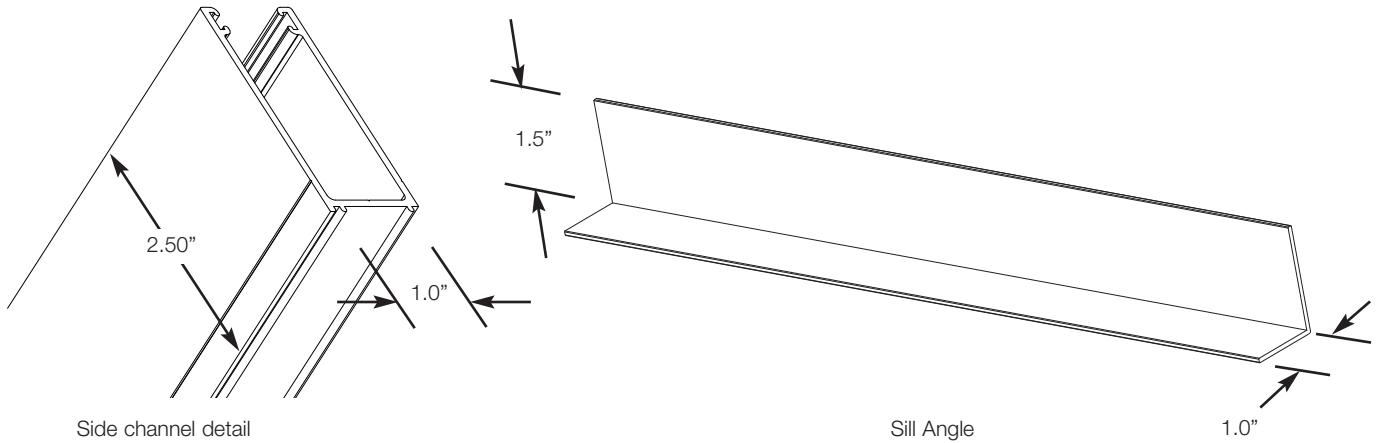

mechanical | hembars

An exposed hembar should be used for blackout systems.

- Exposed hembars include a wool pile bottom to help create a light seal against the sill.
- Custom mill work can be created to allow the hembar to recess into the sill when completely closed.
- Sealed hembars are also available.

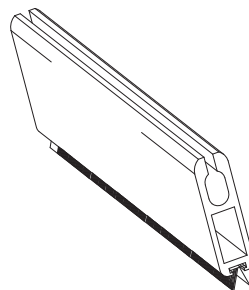

mechanical | roller 64 | brackets

The system uses one simple bracket for any installation (jamb, wall, pocket, ceiling). The same bracket is used for the left and right sides.

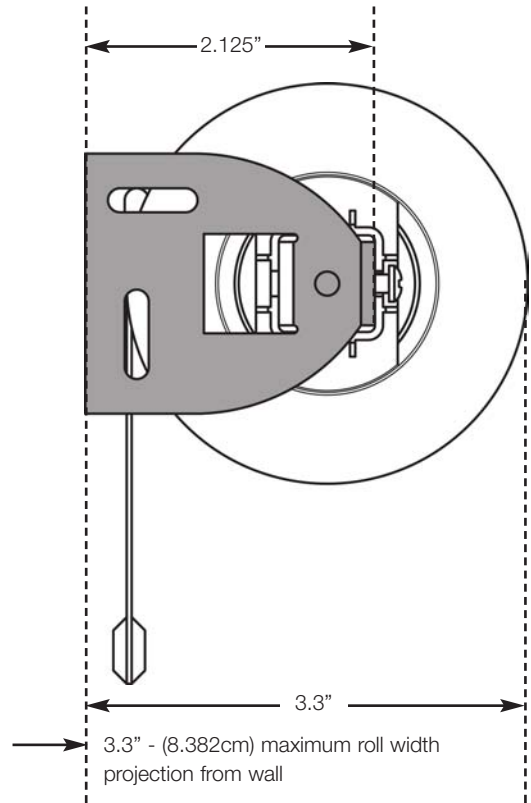
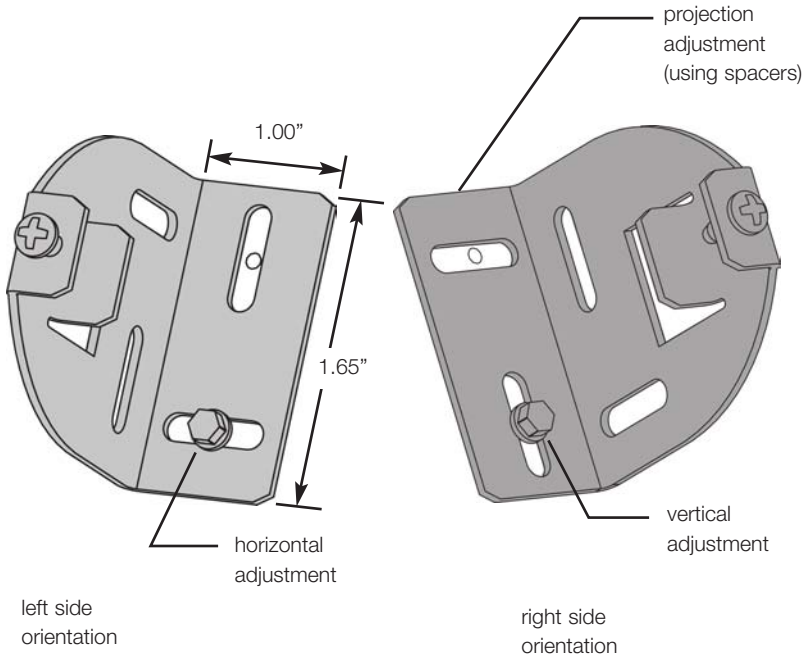

mechanical | roller 100 | jamb brackets

All roller 100 bracket systems offer leveling, centering and projection adjustments after mounting.

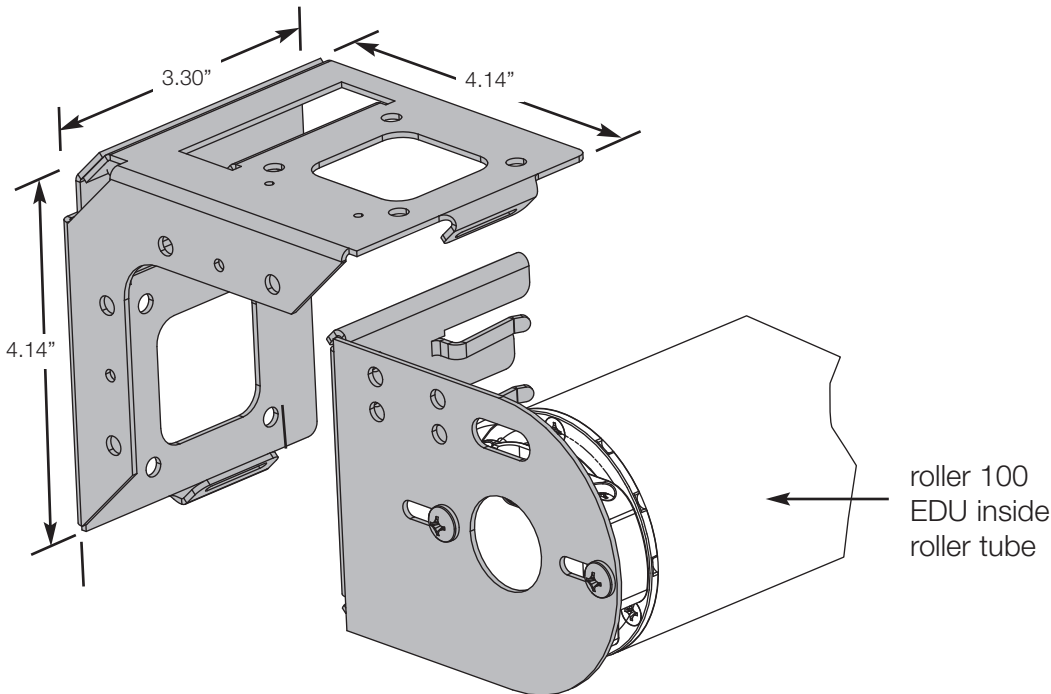

mechanical | roller 100 | ceiling brackets

Ceiling mount bracket and sub-bracket

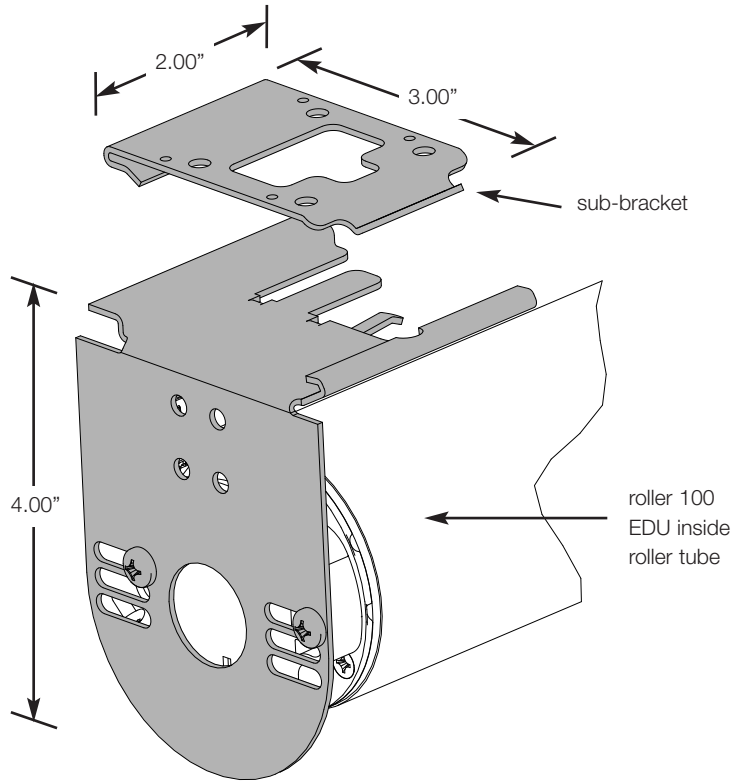

mechanical | roller 100 | wall brackets

Wall mount bracket and sub-bracket

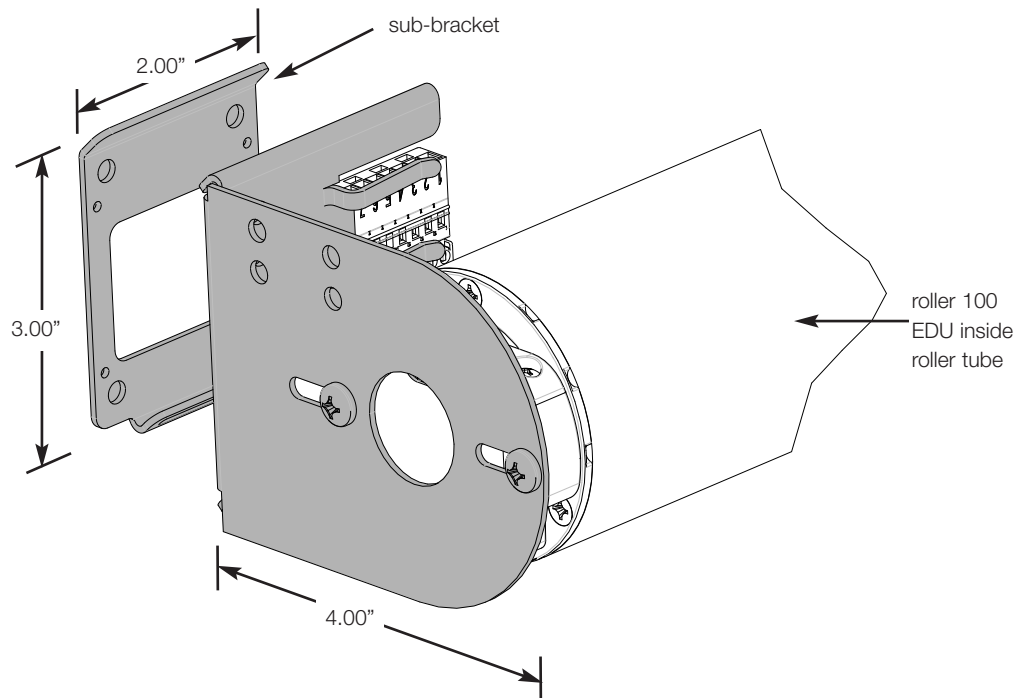

MECHANICAL COMPONENTS

mechanical | roller 100 | dual-mounted

dual-mounted bracket system

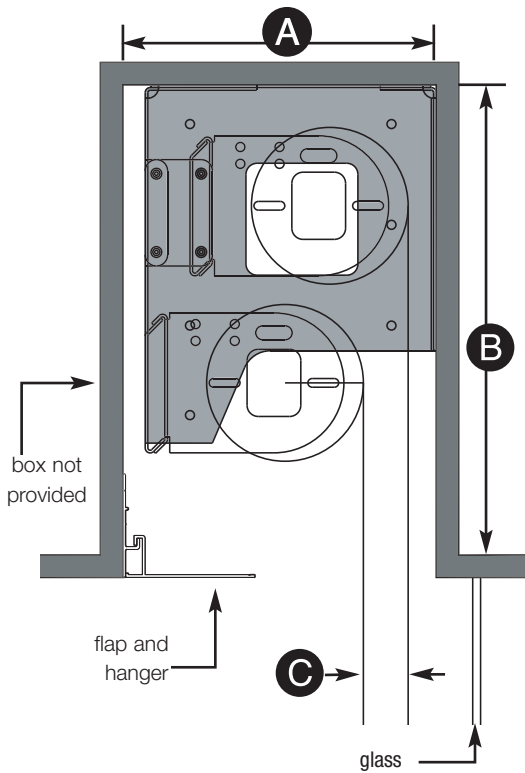

recessed solution shown using dual-mounted brackets (model# SVQ-CWJ-DUAL-BRK) and wall mounted Sivoia QED roller shades

DIMENSIONS

- A** 7.0" (17.78cm)
- B** 11.0" (27.94cm)
- C** 1.0" (2.54cm)
(varies as shades raise and lower)

mechanical | roller 225

The roller 225 system can only be installed in a jamb or recess position. This bracket system also offers leveling, centering and projection adjustments after mounting.

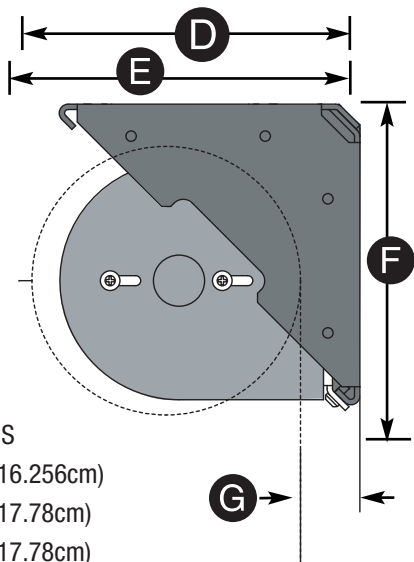

DIMENSIONS

- D** 6.40" (16.256cm)
- E** 7.00" (17.78cm)
- F** 7.00" (17.78cm)
- G** 1.10"-2.00" (2.79-5.08cm)
range of fabric projection

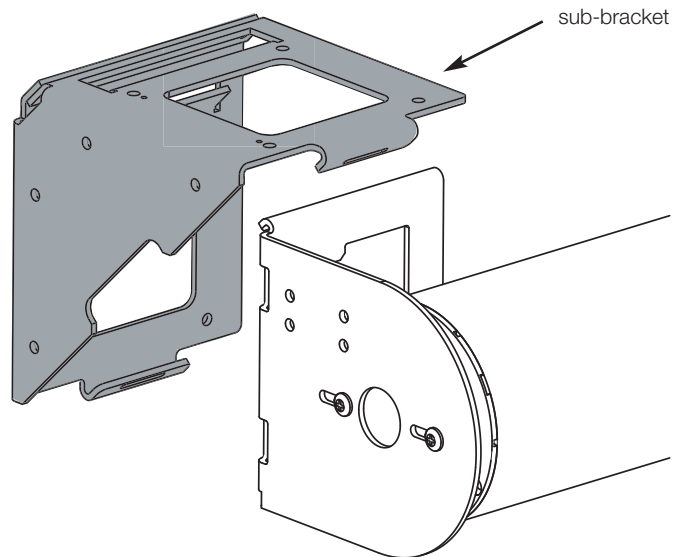

MECHANICAL COMPONENTS

mechanical | roller 100 | corner installations

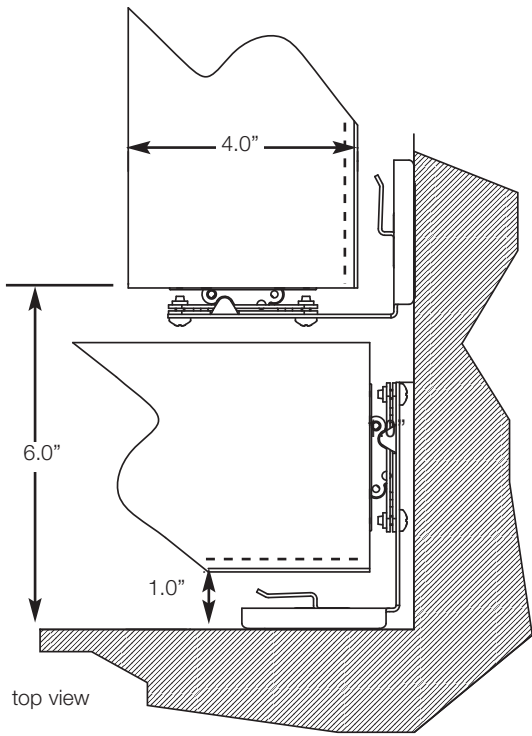

Option 1
Roller shades mounted at same height meeting in a corner. Regular fabric roll shown.

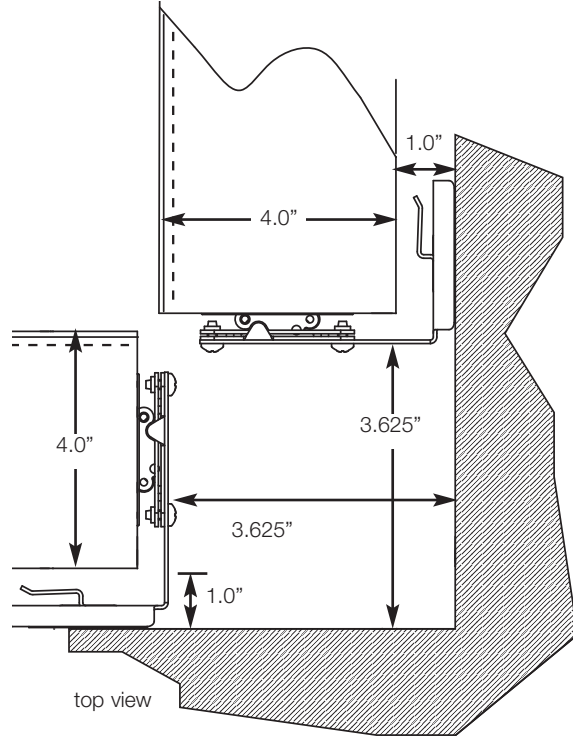

Option 2
Roller shades mounted parallel meeting in a corner. Reverse fabric roll shown. A reverse roll here minimizes the fabric gap when the shades are lowered.

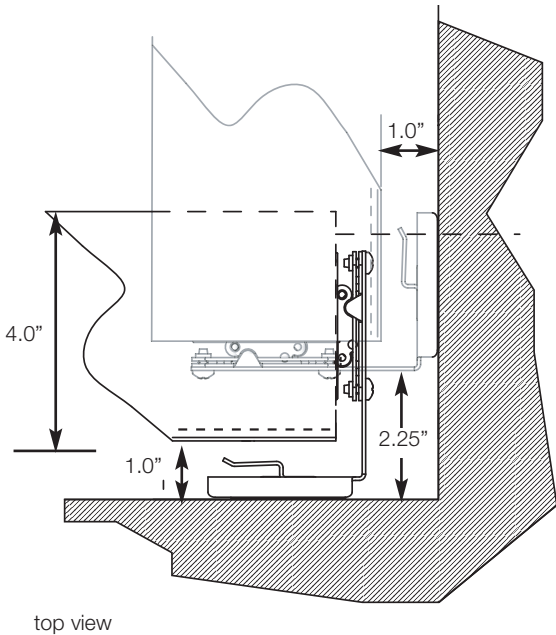

Option 3
Roller shades mounted in vertical stack, meeting in a corner. Standard fabric roll shown. The lower shade is installed up to 2.25" off the perpendicular wall to allow the fabric from the upper shade to drop behind the lower shade's idler bracket.

Note: dashed lines indicate fabric drop

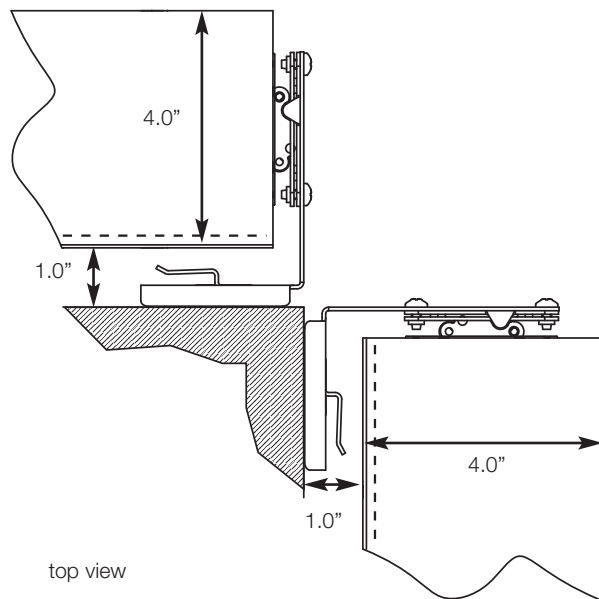

Option 4
Roller shades mounted parallel meeting at an outside corner. Regular fabric roll shown to minimize fabric gaps.

Note: dashed lines indicate fabric drop

MECHANICAL COMPONENTS

mechanical | system dimensions

Roller 64

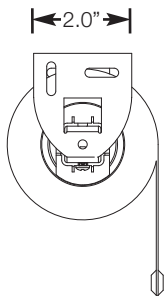
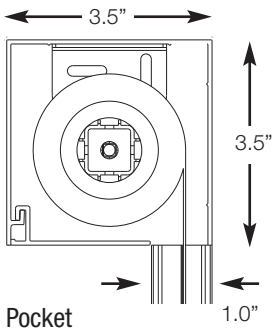

Ceiling

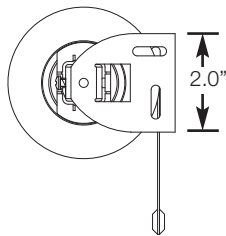

Wall/Jamb

Roller 100 Pocket Bracket

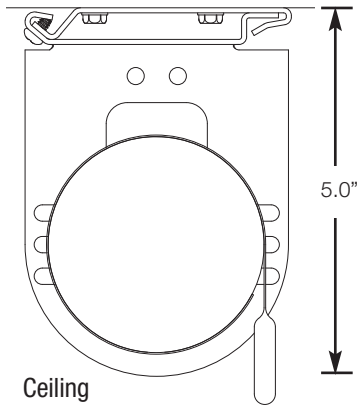
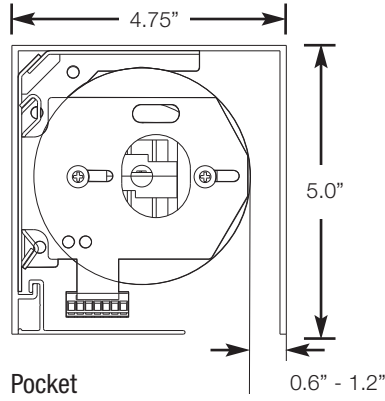

Wall

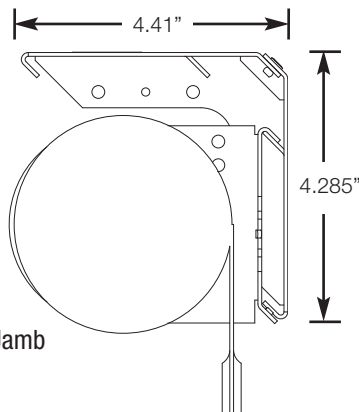

Roller 225

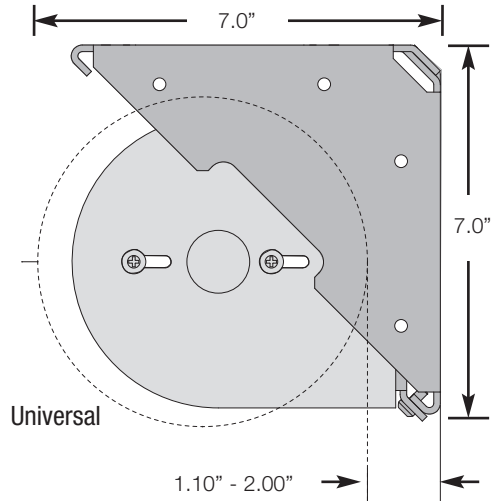

MECHANICAL COMPONENTS

how to measure | in-line coupling

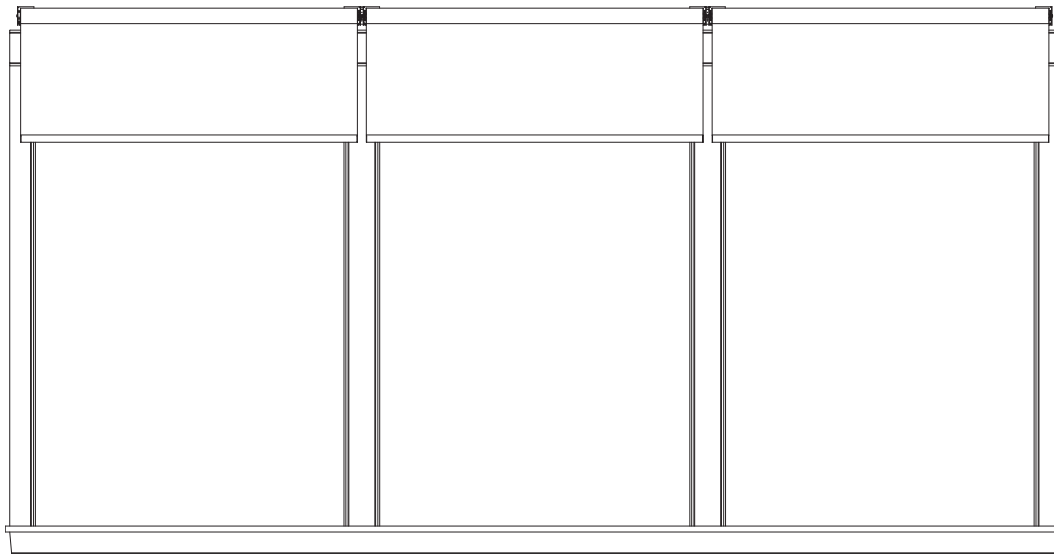

Coupled shades may provide a means to reduce the total installed cost of the Sivoia QED system. The number of EDUs on a job may be reduced where independent control of adjacent shades is not needed. With a reduction in the number of EDUs there will be an equal reduction in transformers and wiring. This may also simplify the programming and setup of the job.

In an in-line coupled system, one EDU is lifting up to three fabric panels. The EDU can lift approximately 100 square feet of fabric. For a specific application, use the Shade Configuration Tool (available at www.lutron.com) to verify that dimensions and fabric panel sizes fall within the scope of the Sivoia QED system.

With the in-line coupled system, up to three shade panels can be operated from a single EDU. A coupling pin provides for phase adjustment that allows the installer to adjust the hembar alignment after installation and without removing the fabric panels from the tube. Likewise, the in-line coupled system provides the same leveling, shade centering, and projection adjustment that is provided on the single roller Sivoia QED shade. Also, in-line coupling is supported for all five mounting conditions: wall, ceiling, jamb/recess, fascia, and pocket. Fabric gaps are shown in the illustration below.

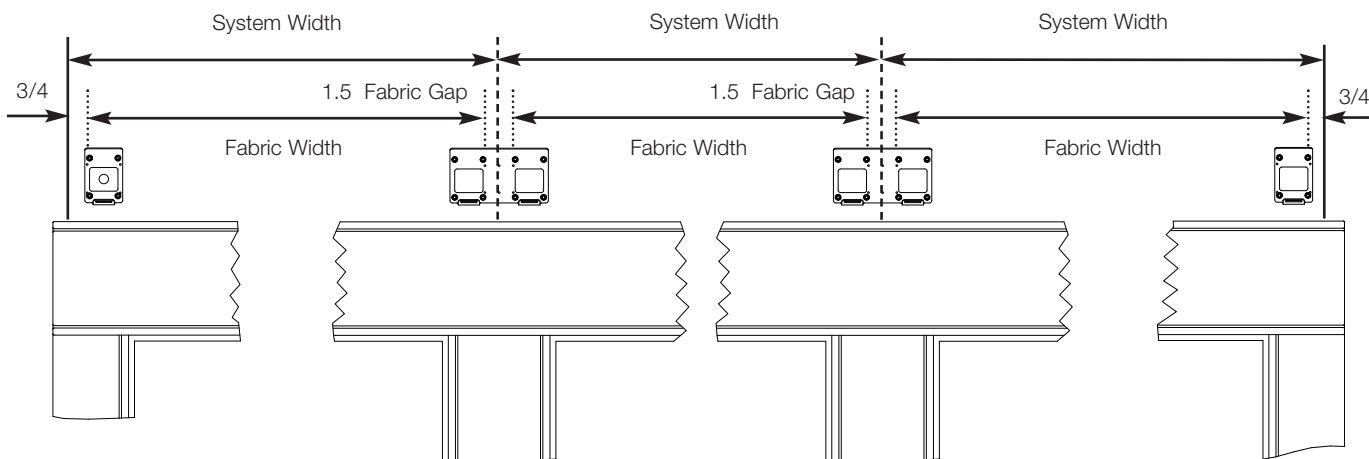

MECHANICAL COMPONENTS

3 | wiring

prewire | roller 64

Choose one of the options below to drill for cable access.

Note: Cable should exit from wall, ceiling, or jamb on EDU side of system.

Note: Leave 12-18" (30.5-45.7cm) of cable exposed.

Wall Mount with wires through:

Jamb Mount with wires through:

Ceiling Mount with wires through:

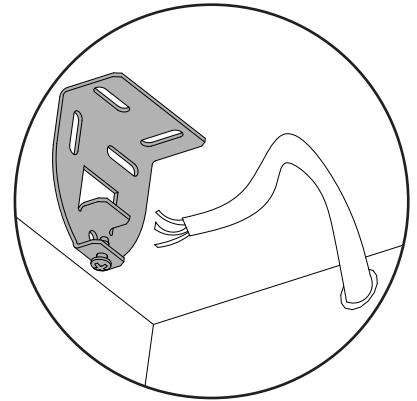
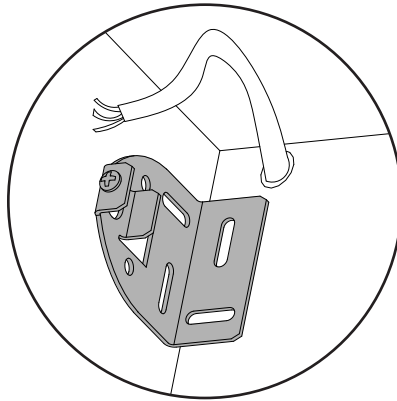
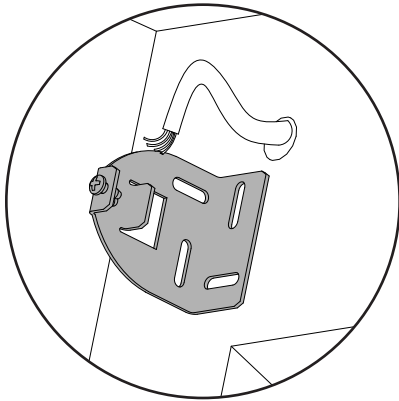

A) Wall: 1" in from end of system and .5" from top of bracket

A) Wall: .5" from ceiling and .5" from outside of jamb

A) Wall: 1" in from end of system and .5" from ceiling

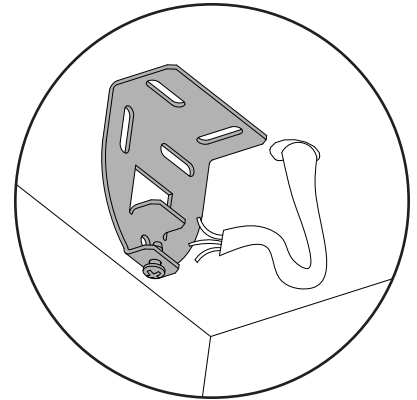
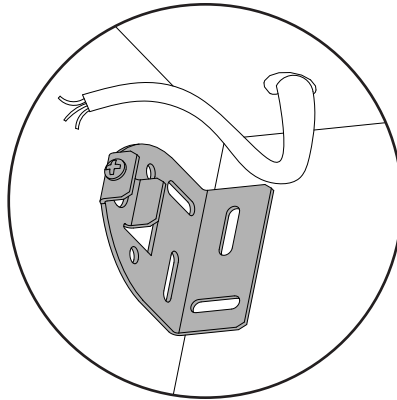
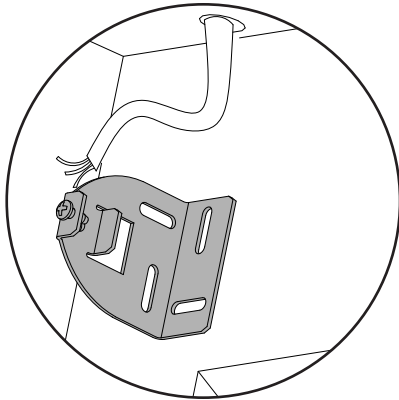

B) Ceiling: .5" in from end of system and .5" from mounting wall

B) Ceiling: .5" from wall and .5" from outside of jamb

B) Ceiling: 1" in from end of system and .5" from back of bracket

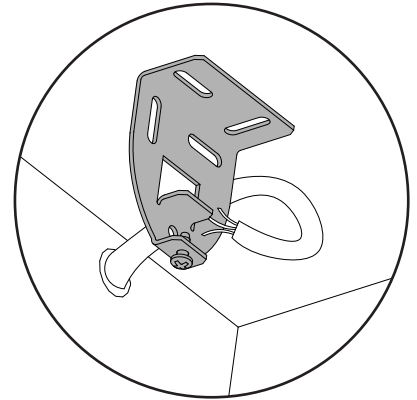
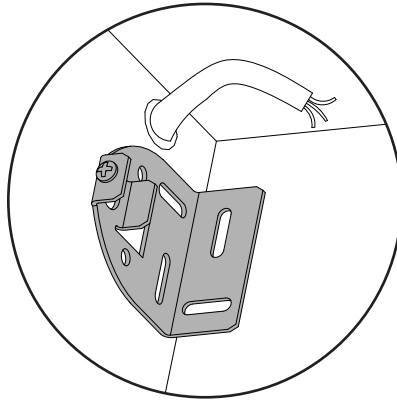
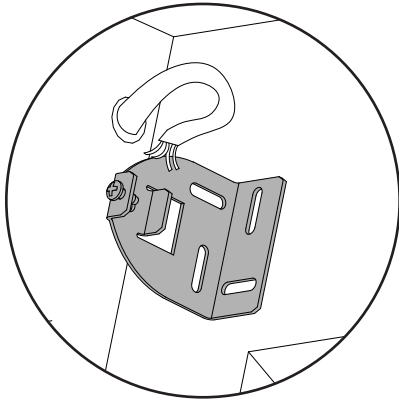

C) Jamb: 1" from top of bracket and .5" from mounting wall

C) Jamb: .5" from ceiling and .5" from wall

C) Jamb: 1" from back of bracket and .5" from ceiling

prewire | roller 100 | wall and ceiling mount

Determine where to drill for cable access to EDU.
Leave 12-18" of cable exposed.

Wall Mount

cable exiting wall

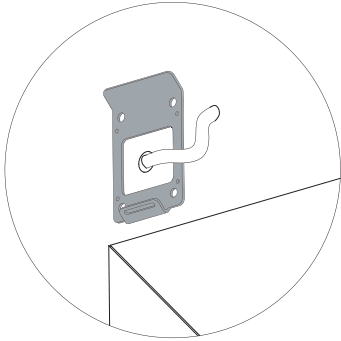

Drill for cable 1 1/4" - 2" from end of system and 2 - 2 1/2" from top of system

cable exiting ceiling

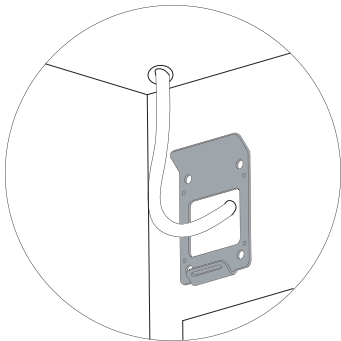

Drill for cable 1/2" from end of system and 1/2" from mounting wall.

cable exiting jamb

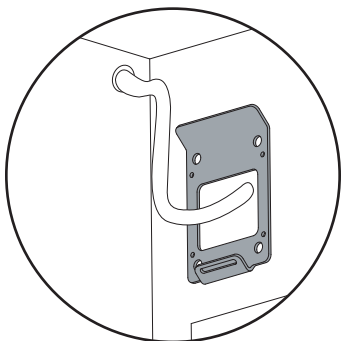

Drill for cable 1/2" from top top of system and 1/2" from mounting wall.

Ceiling Mount

cable exiting wall

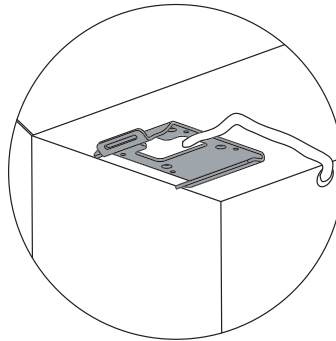

Drill for cable 3 1/4" from end of system and 1/2" down from top of system.

cable exiting ceiling

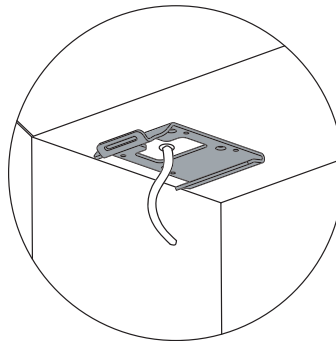

Drill for cable 1 1/4" - 2" from end of system and 1 1/4" - 1 3/4" from back of system.

cable exiting jamb

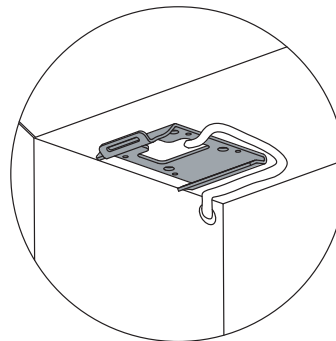

Drill for cable 1/2" from top top of system and 3/4" from mounting wall.

prewire | roller 100 | jamb and fascia/top-back cover

Determine where to drill for cable access to EDU.
Leave 12-18" of cable exposed.

Jamb Mount

cable exiting wall

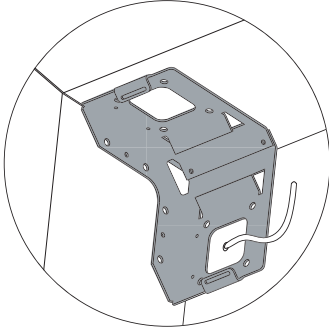

Drill for cable 2 1/2" - 3" from top of system and 1 1/4" - 2 1/4" from end of system.

cable exiting ceiling

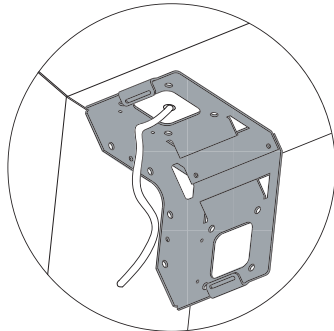

Drill for cable 2 1/2" - 3" from back of the system and 1 1/4" - 2 1/4" from end of system.

cable exiting jamb

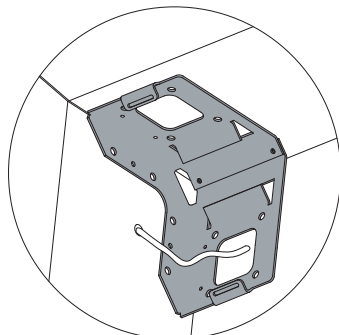

Drill for cable 2" from top and 2" from the back of the system.

Fascia/ Top-back Cover

cable exiting wall

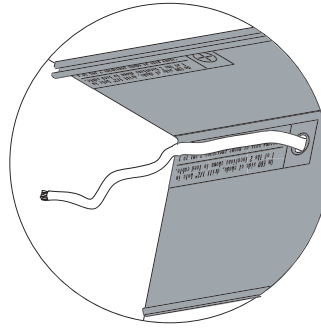

Drill for cable 4" from end of system and 1/2" from top or where indicated on top/back cover.

cable exiting ceiling

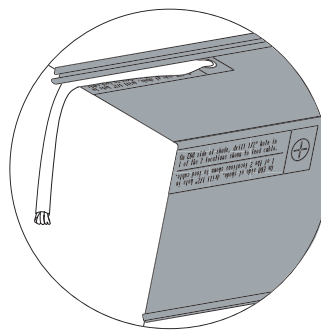

Drill for cable 4" from end of system and 1/2" from front or where indicated on top/back cover.

cable exiting jamb

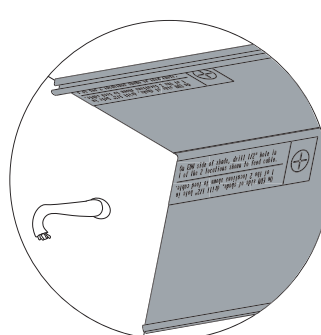

Drill for cable 2" from top and 2" from the back of the Top/Back cover.

prewire | roller 100 | recess pocket

Determine where to drill for cable access into pocket. See options below. Cable should exit from wall, ceiling or jamb on EDU side of pocket.

Roller 225

wall

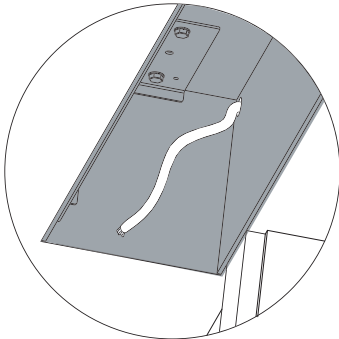

Drill for cable 1/2" from end of pocket and 1/2" from top of pocket.

jamb

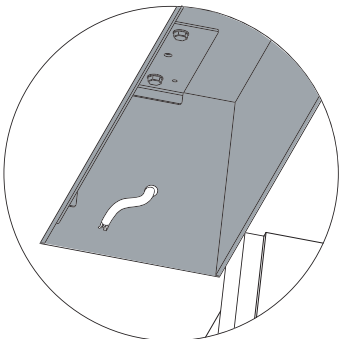

Drill for cable 3-3/4" from top of pocket and 2" from back of pocket.

ceiling

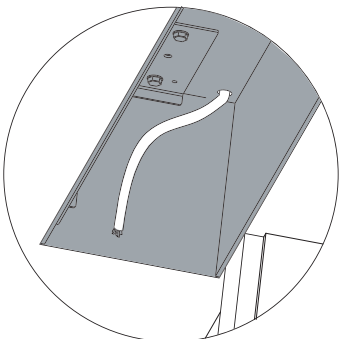

Drill for cable 1/2" from end of pocket and 1/2" from back of pocket.

prewire | roller 100 | dual-mounted

Determine where to drill for cable access. See options below.

Two lengths of 12-18" of cable should exit the ceiling, jamb or either wall on the EDU side of the shades.

ceiling

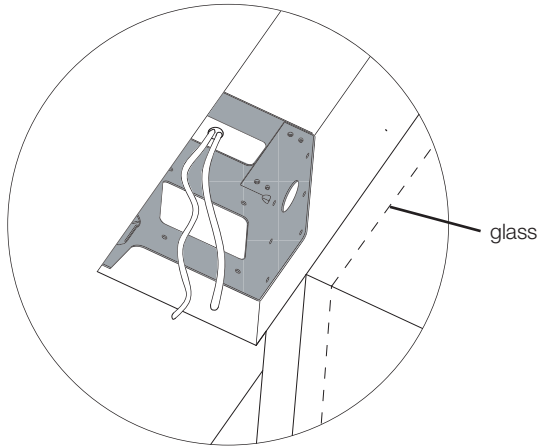

Drill for cable 1 1/2" - 3 1/2" from back and 1 1/4" - 2" from end of system.

wall on glass side

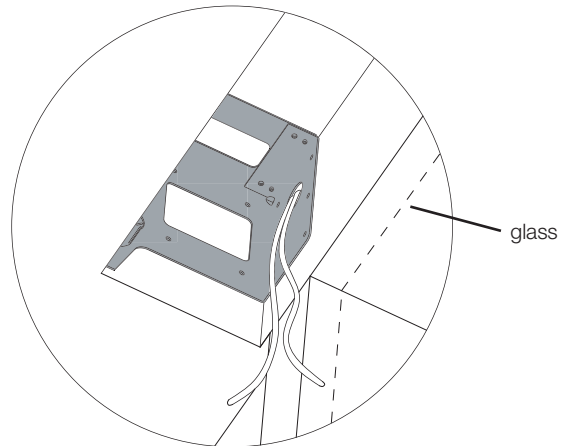

Drill for cables 1 1/2" - 2 1/2" from top and 1 1/2" - 2 1/2" from end of system.

jamb

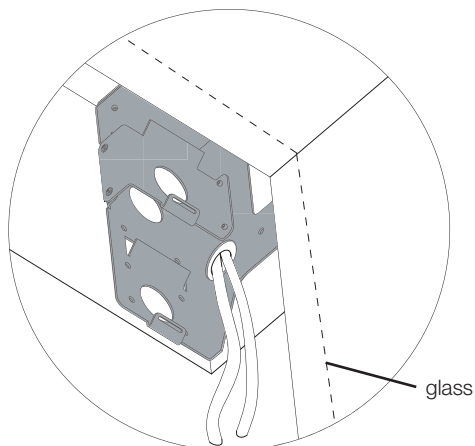

Drill for cable 5 1/4" - 6" from back and 4 1/4" - 5" from top of system.

wall opposite glass side

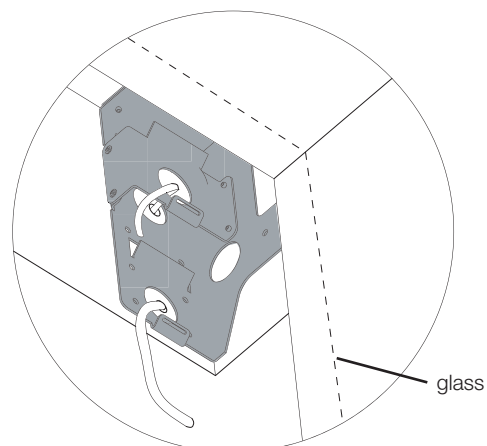

Drill for one cable 2 1/2" - 3 1/2" from top and 1 1/2" - 2 1/2" from end of the system. Drill for second cable 6 1/2" - 7 1/2" from top and 1 1/2" - 2 1/2" from end of system.

prewire | roller 225

The Sivoia QED Roller 225 system uses different brackets than the roller 100 system. Two lengths of 12-18" of cable should exit the ceiling, jamb or either wall on the EDU side of the shades.

cable exiting wall

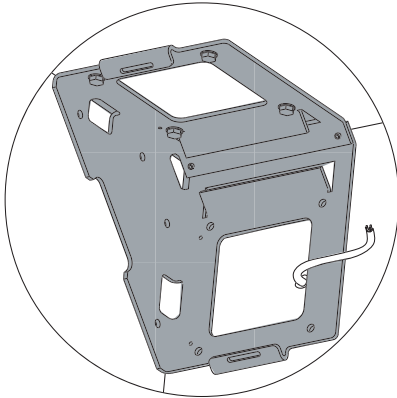

Drill for cable 1 1/2" from end of system and 2 1/2"-4" from top of system.

cable exiting jamb

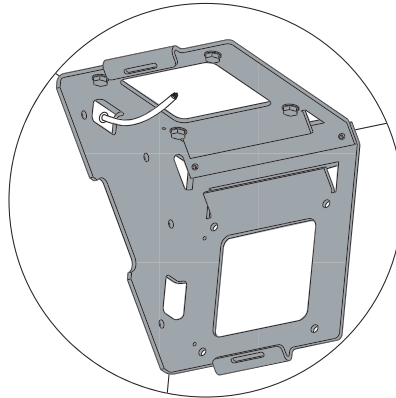

Drill for cable 1/2" from top of system and 3 1/2" from back of system.

cable exiting ceiling

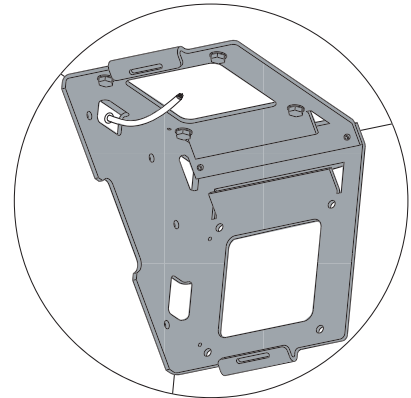

Drill for cable 1/2" to 3 3/4" from end of system and 2 1/2"- 4 1/2" from back of system.

single EDU | plug-in transformer

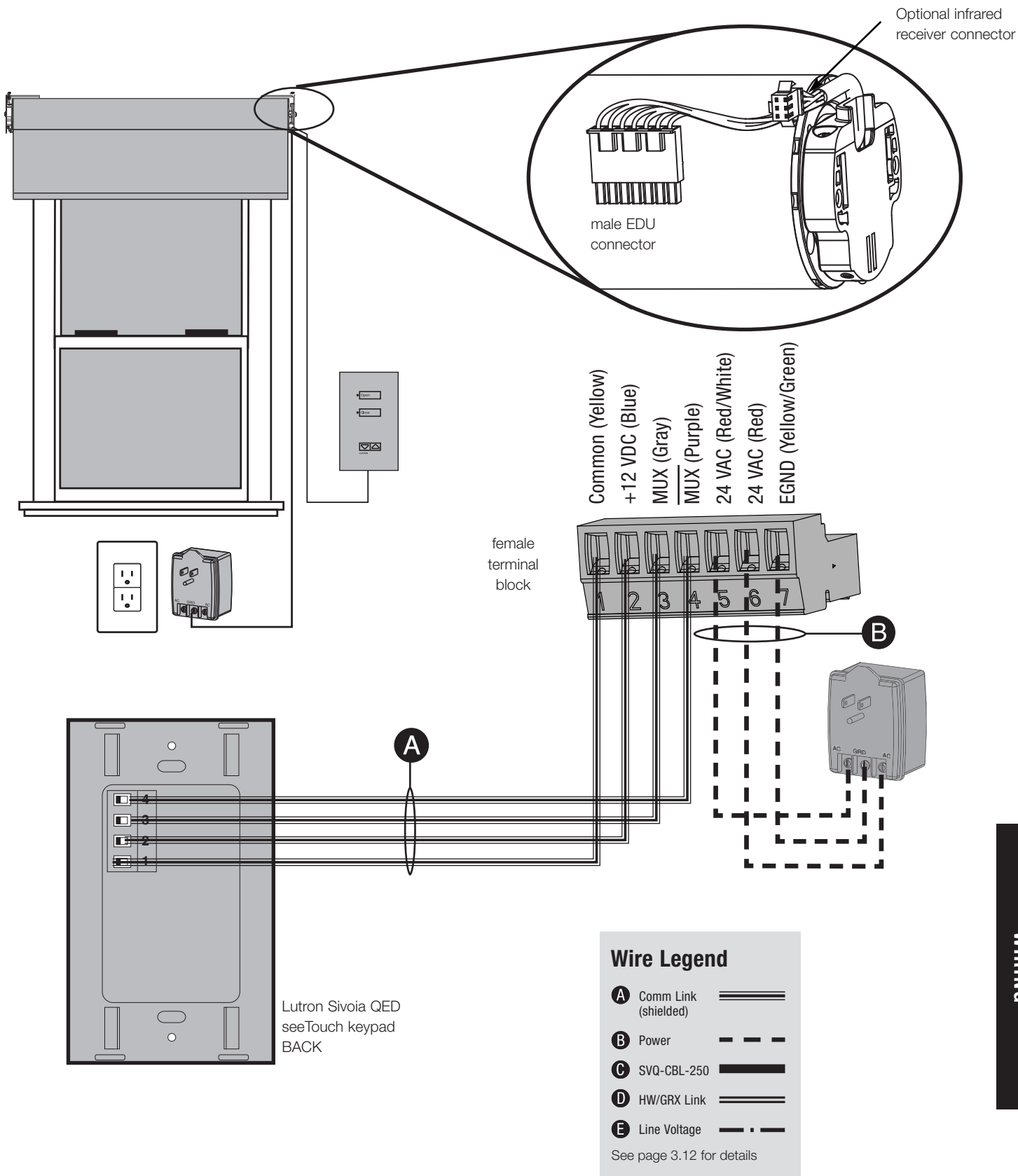

WIRING



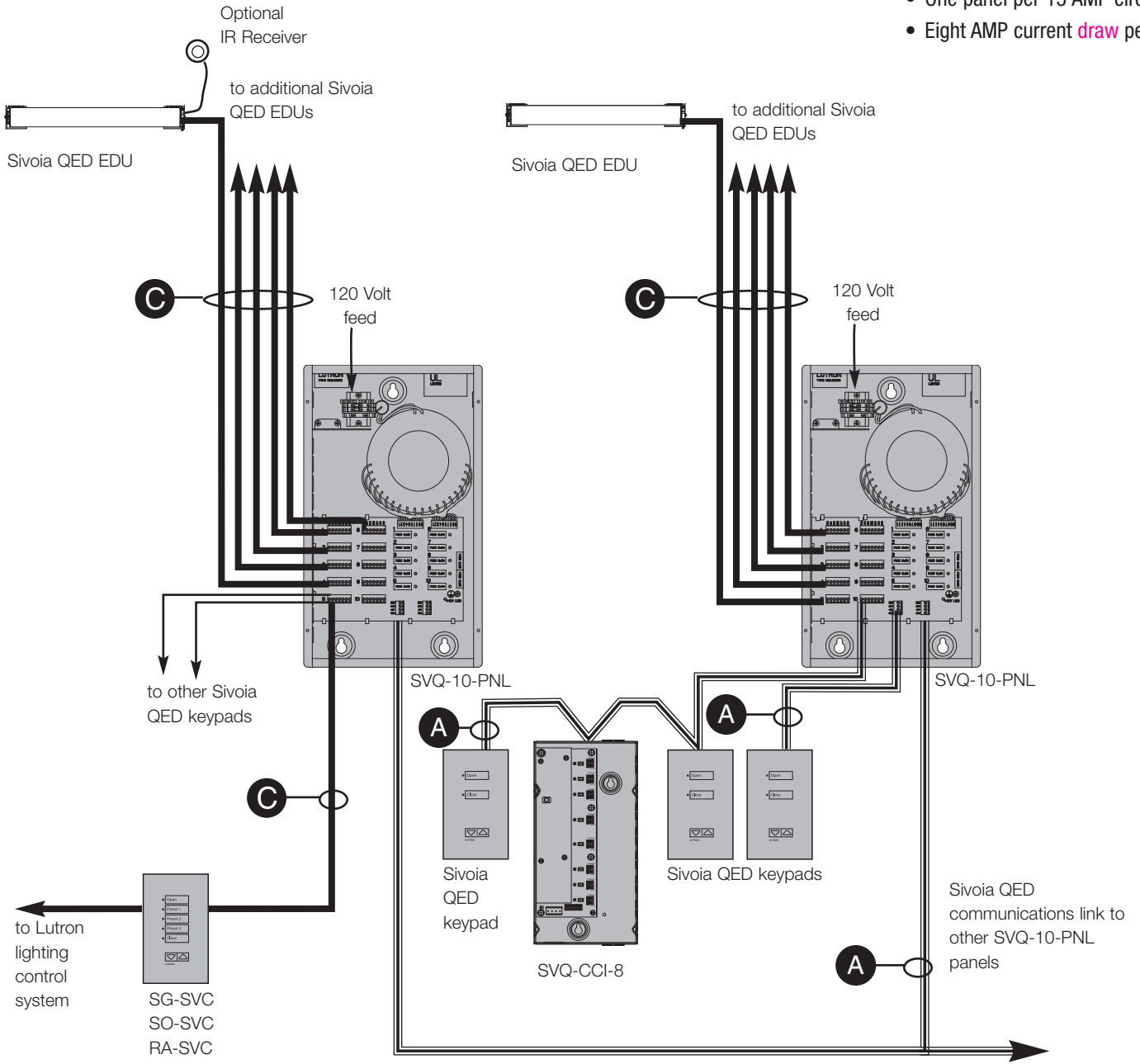

transformer panel | overview

- One panel per 15 AMP circuit.
- Eight AMP current draw per panel.



(Integration to Lutron lighting control systems)

Wire Legend

- A** Comm Link (shielded) 
- B** Power 
- C** SVQ-CBL-250 
- D** HW/GRX Link 
- E** Line Voltage 

See page 3.12 for details

transformer panel | home-run wiring

Advantages:

- No derating of distances
- Most convenient for pre-wire and installation
- Most accessible for troubleshooting

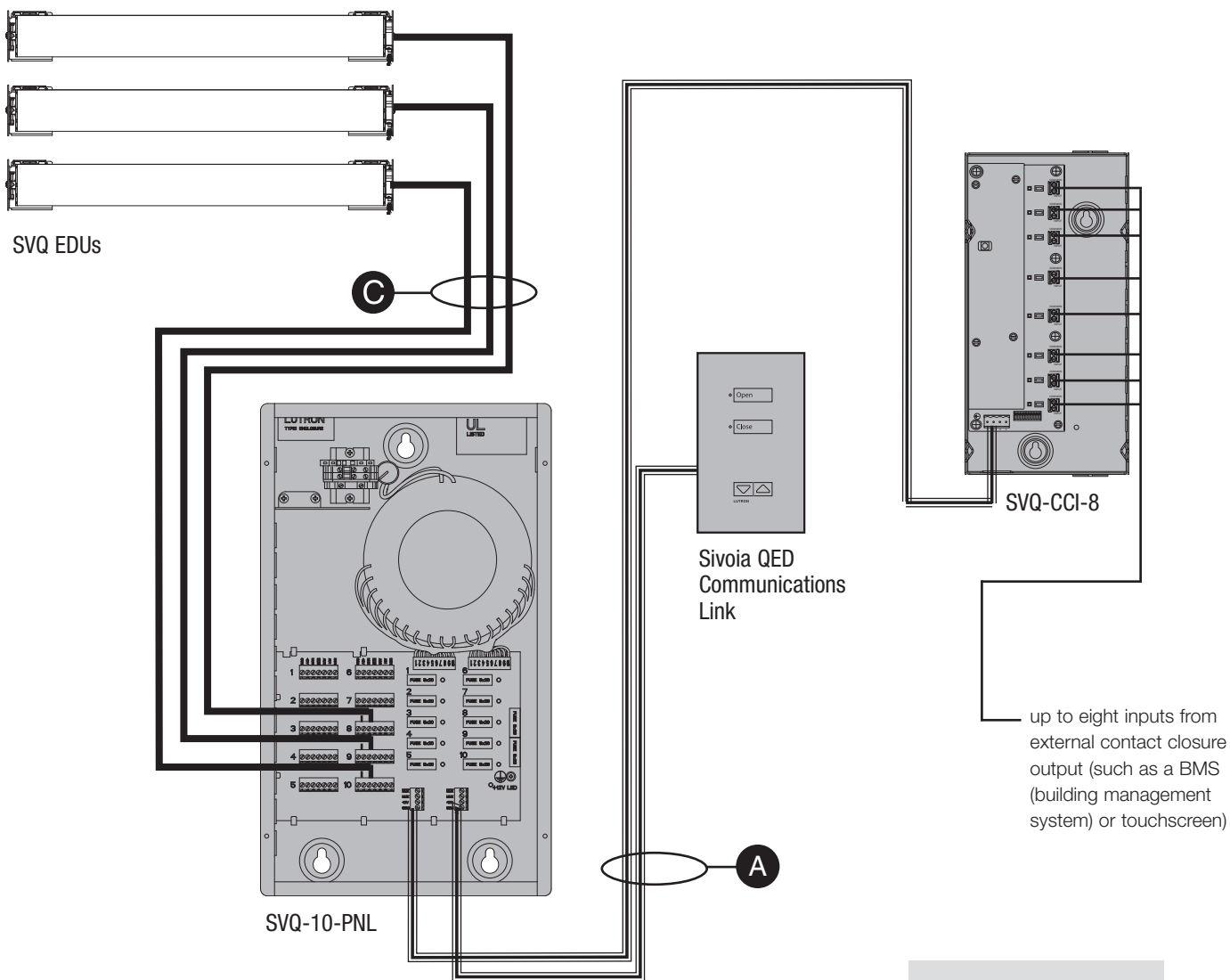

Note: When the number of keypads in an installation exceeds the number of Sivoia QED EDUs, external keypad power supplies would be required. See page 1.6

Wire Legend

- A** Comm Link (shielded)
- B** Power
- C** SVQ-CBL-250
- D** HW/GRX Link
- E** Line Voltage

See page 3.12 for details

WIRING

transformer panel | with communications link

- Utilize a custom Lutron cable to connect all power from each EDU to the transformer panel in a home-run fashion.

Four conductor low-voltage wiring then links the panel to all keypads and contact closure interfaces. See page 1.6 for limitations on daisy-chaining controls on one branch.

Note: When the number of keypads in an installation exceeds the number of Sivoia QED EDUs, external keypad power supplies would be required. See page 1.6 for more on this feature.

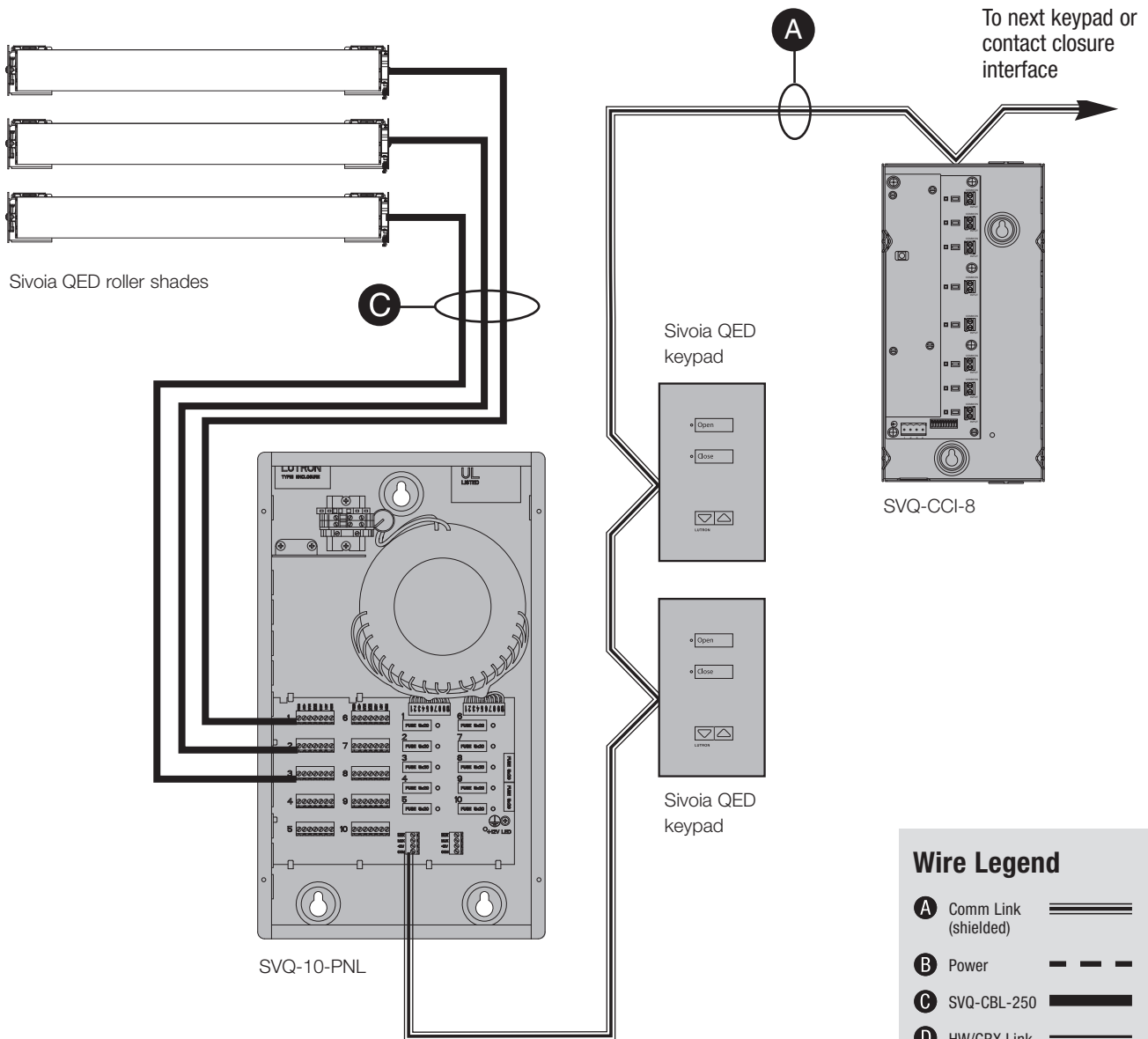

transformer panel | wire specifications

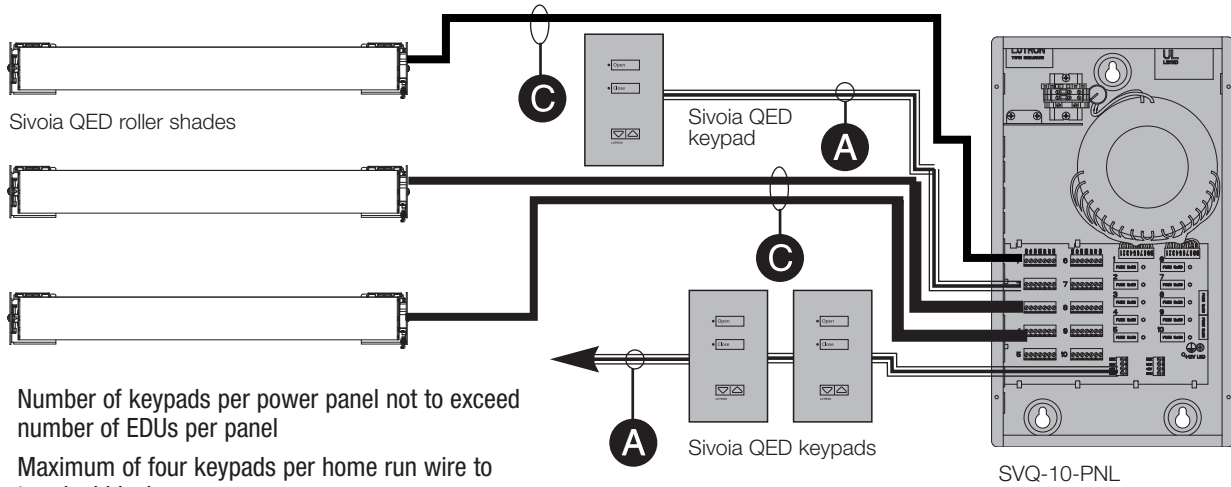

- Number of keypads per power panel not to exceed number of EDUs per panel
- Maximum of four keypads per home run wire to terminal block

WIRE TYPES

MAXIMUM WIRE LENGTH

ICON

WIRE TYPES	MAXIMUM WIRE LENGTH	ICON
<p>A Comm Link 4 Conductor #18AWG (twisted and shielded) Maximum comm Link - 4000 feet</p> <p>Note: Lutron cable GRX-CBL-346S-500 can be used for the 4-wire communication link so long as the #18awg conductors are used for +12V and Common.</p>	<p>Keypad to Power Panel</p> <p>1 keypad - 1000 feet 2 keypads - 500 feet 3 keypads - 300 feet 4 keypads - 200 feet</p>	
<p>B Power Supply 3 Conductor #16-20AWG</p>	<p>EDU to Panel</p> <p>#16AWG - 200 feet #18AWG - 150 feet #20AWG - 100 feet</p>	
<p>C SVQ-CBL-250 (A and B combined) 7 Conductor, being: 2- #16AWG Power Supply (red, red/white) 1 -#18AWG Earth Ground (green/yellow) 4- #18AWG Comm Link (blue, yellow, violet, gray, twisted and shielded)</p>	<p>EDU to Power Panel - 200 feet</p> <p>1 keypad to Power Panel - 1000 feet 2 keypads to Power Panel - 500 feet 3 keypads to Power Panel - 300 feet 4 keypads to Power Panel - 200 feet</p>	



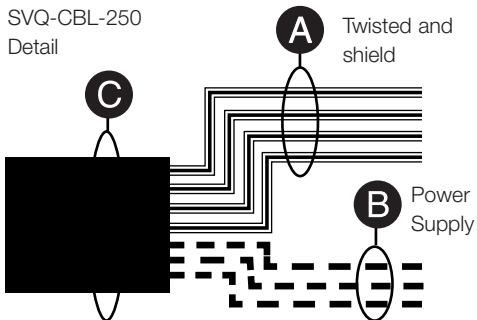

Note: If Sivoia QED cable is used for keypad wiring, there would be extra conductors left unused.

Note: power supply wires should NOT be in the same shielding as communication wires.



transformer panel | detail

Wire Legend

- A** Comm Link (shielded) 
 - B** Power 
 - C** SVQ-CBL-250 
 - D** HW/GRX Link 
 - E** Line Voltage 
- See page 3.12 for details

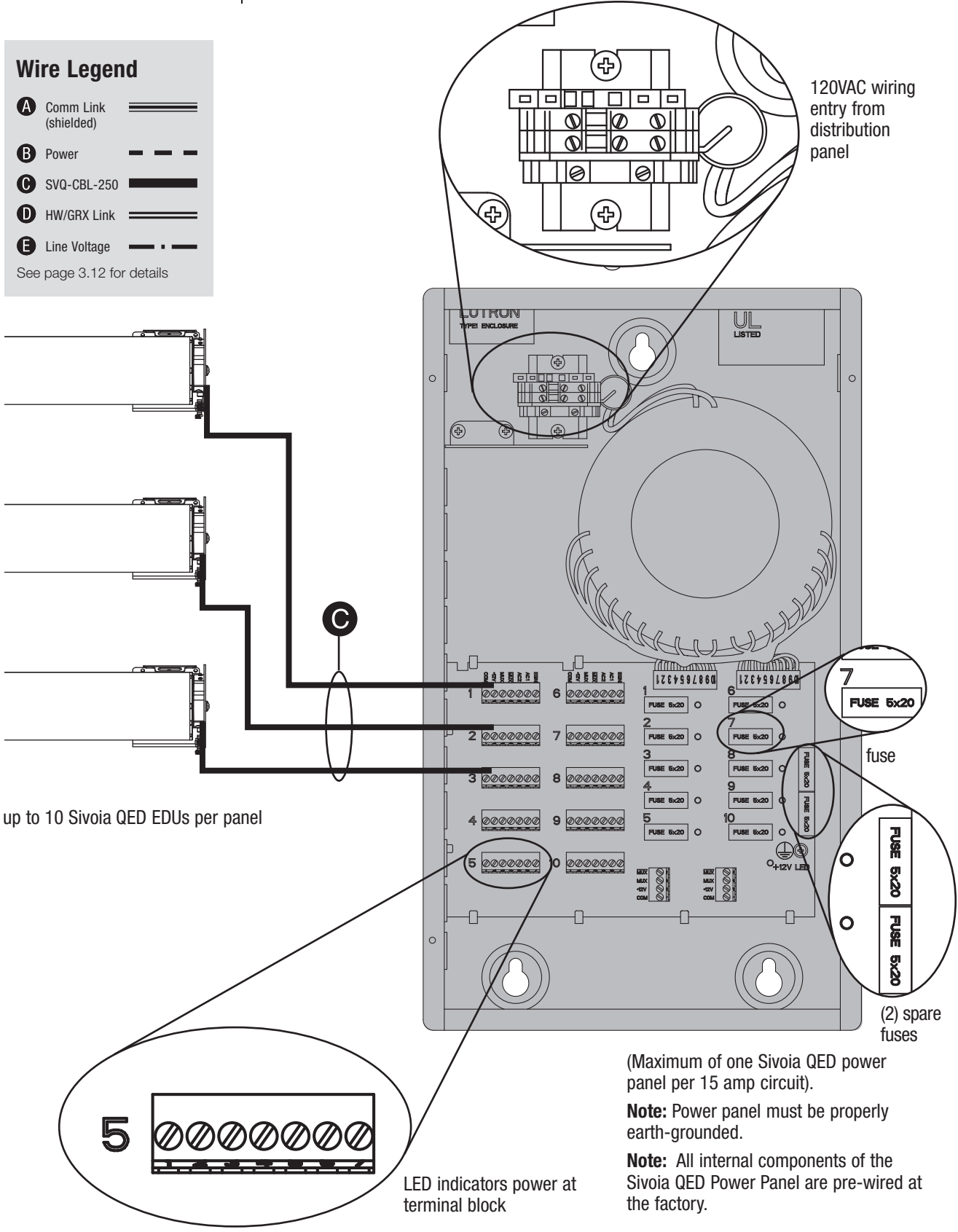

up to 10 Sivoia QED EDUs per panel

(Maximum of one Sivoia QED power panel per 15 amp circuit).

Note: Power panel must be properly earth-grounded.

Note: All internal components of the Sivoia QED Power Panel are pre-wired at the factory.

WIRING

multiple EDUs | individual transformers | overview

For larger systems, distribute keypads evenly on link - maximum one keypad between EDUs.

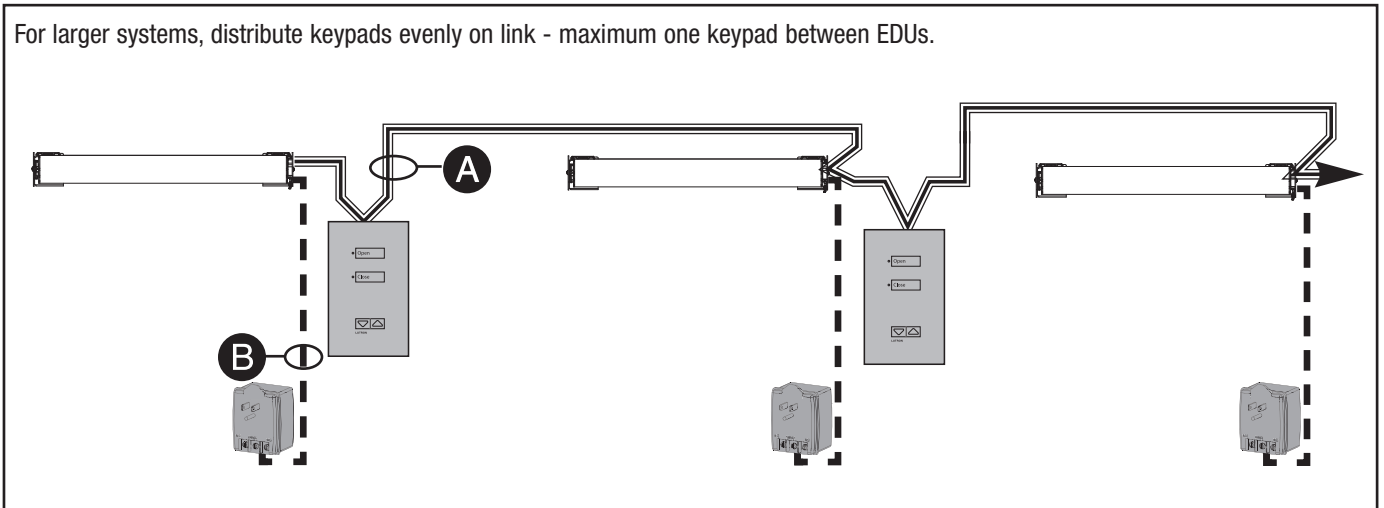

Up to four keypads and 400 total feet of communications wire, no requirement for even distribution

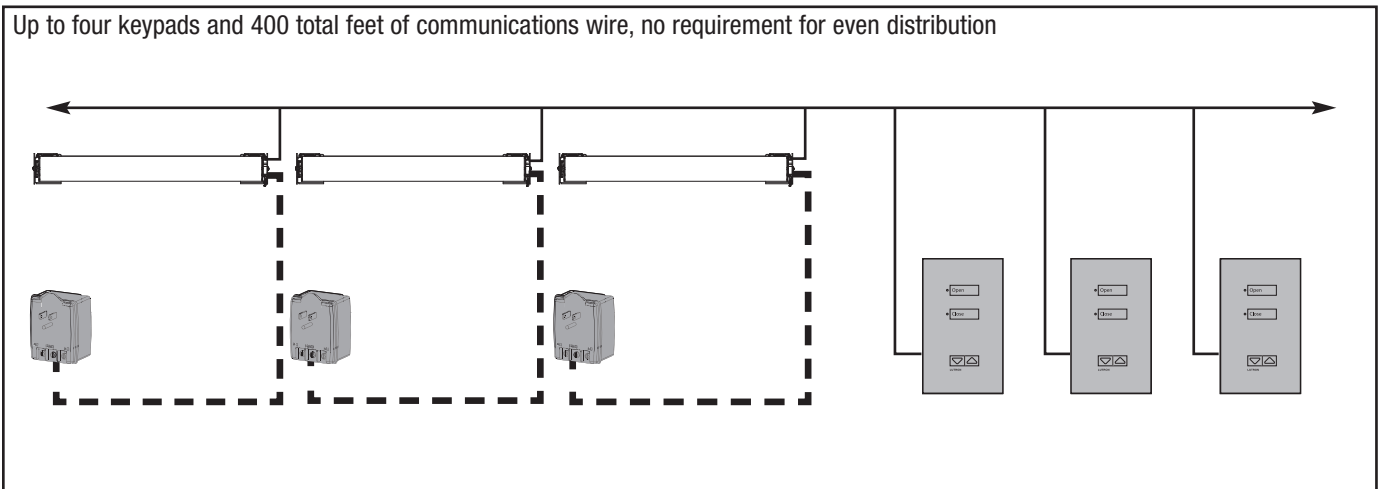

A Communications Link
4 Conductor #18AWG (twisted and shielded)

Maximum Wire Length
EDU to EDU - 500 feet
Maximum total communication link - 4000 feet

B Power Supply
3 Conductor #16-20AWG

Maximum Wire Length
Transformer to EDU
#16AWG - 200 feet
#18AWG - 150 feet
#20AWG - 100 feet

Wire Legend



- A** Comm Link (shielded)
- B** Power
- C** SVQ-CBL-250
- D** HW/GRX Link
- E** Line Voltage

See page 3.12 for details

multiple EDUs | individual transformers | detail

- Every keypad, CCI, and EDU is connected by the Sivoia QED™ Communication Link.
- Wire each EDU to a Sivoia QED plug-in transformer, junction-box-mount transformer, or a Sivoia QED power panel.
- Each EDU must be EARTH grounded.
- Each transformer, of any type, can power ONLY ONE EDU, regardless of shade size.

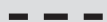
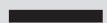
Wire Legend

- A** Comm Link (shielded) 
- B** Power 
- C** SVQ-CBL-250 
- D** HW/GRX Link 
- E** Line Voltage 

See page 3.12 for details



female EDU connector

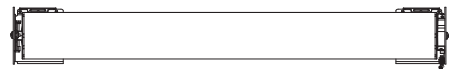

female EDU connector

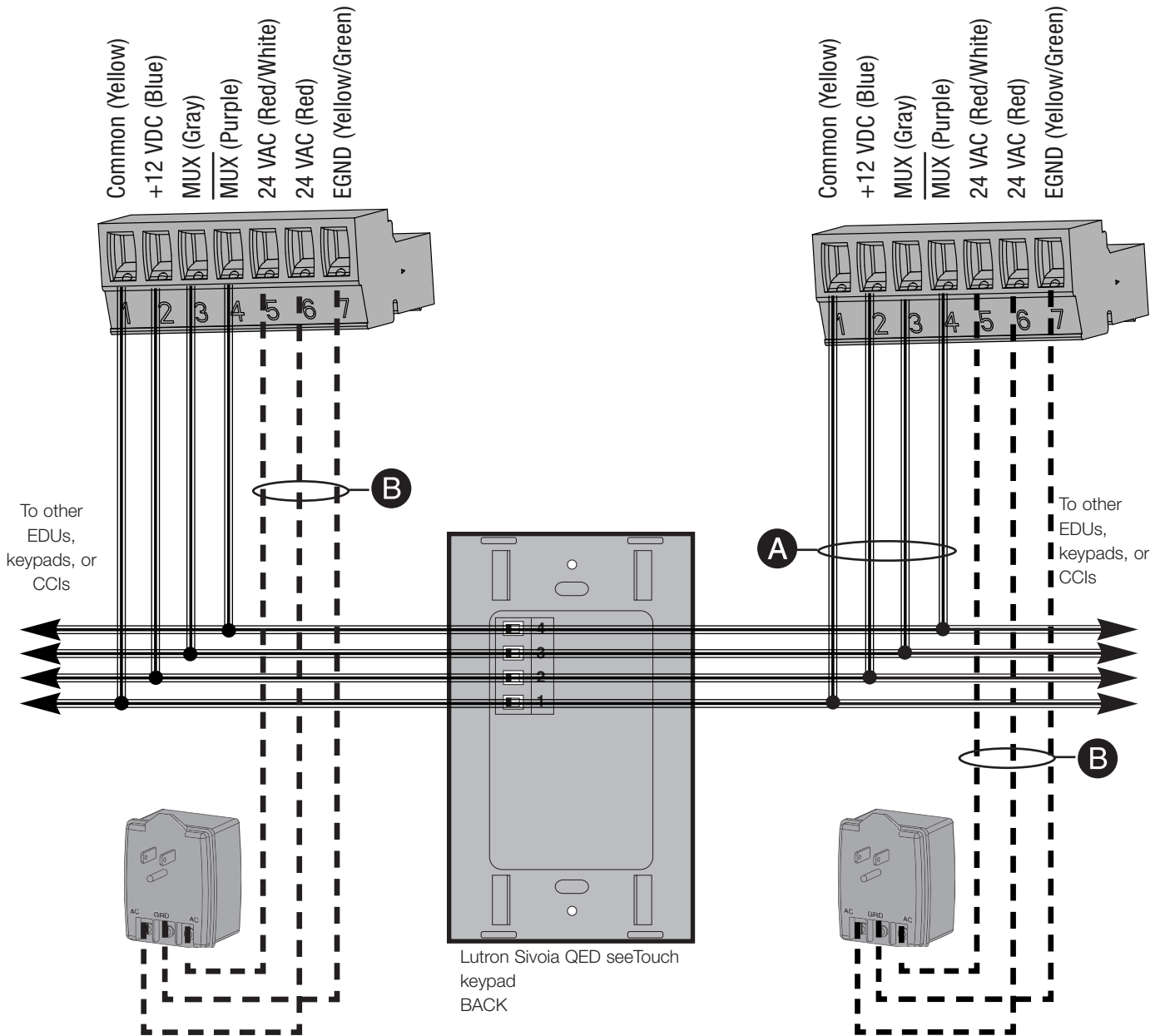

WIRING

4 | integration

HomeWorks® overview

Wire Legend

A Comm Link (shielded)	=====
B Power	-----
C SVQ-CBL-250	=====
D HW/GRX Link	=====
E Line Voltage	- . - . - .

See page 3.12 for details

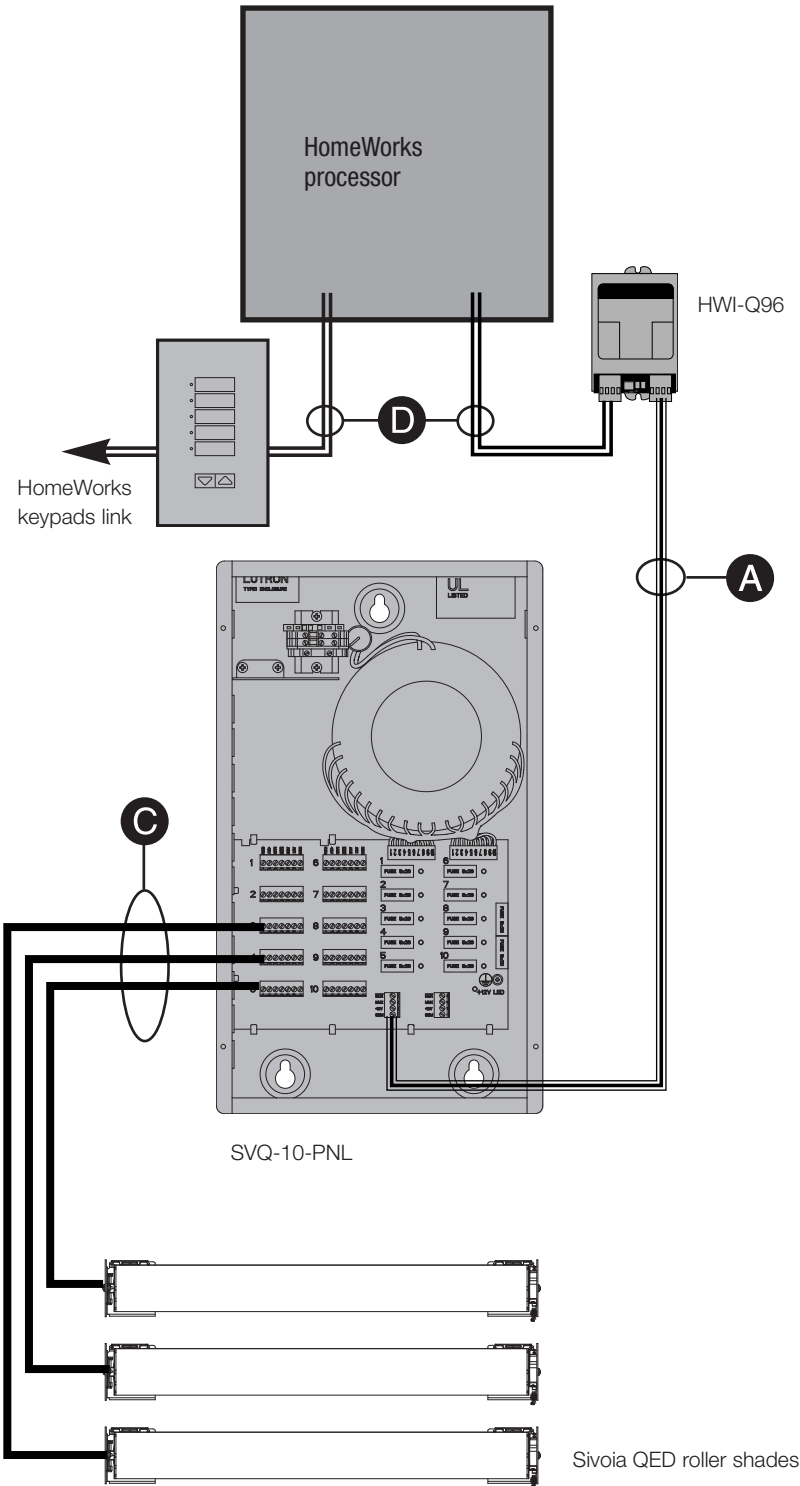

- Sivoia QED EDUs can be controlled directly from the HomeWorks 4 or 8 series processor using the HWI-Q96 SOLOS™ integrator.
- Control up to 96 EDUs.
- Each EDU counts as a zone on the HomeWorks processor.
- QED keypads may be used but count against the 96 device limit. QED keypads cannot be programmed using the HomeWorks processor.

HomeWorks® HWI-Q96 S0Los™ detail

Sivoia QED to HomeWorks

This detail illustrates the wiring of the Sivoia QED system to the HWI-Q96 component.

This allows HomeWorks to directly control any shade or group of shades within the entire Sivoia QED system.

INTEGRATION

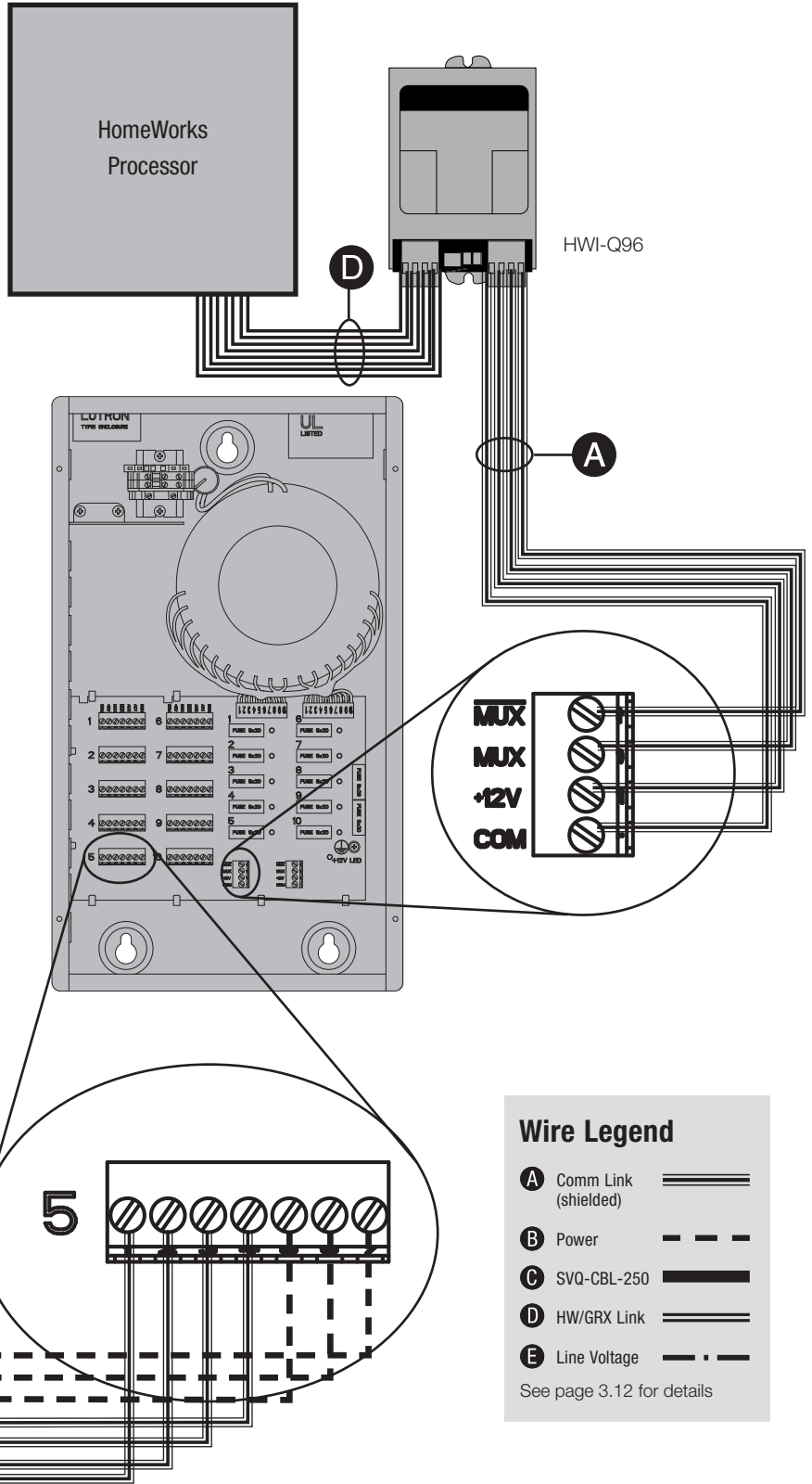

GRAFIK® 3000 | overview

Sivoia EDUs can be controlled directly from the GRAFIK 3000 wallstation by using the SG-SVC control. The control coordinates the movement of Sivoia EDUs with lighting controls in preset scenes on the GRAFIK Eye® throughout an entire room such as a classroom or living room. One SG-SVC is required per group of shades moving in unison. The SG-SVC will operate all window treatments on the Sivoia QED link.

INTEGRATION

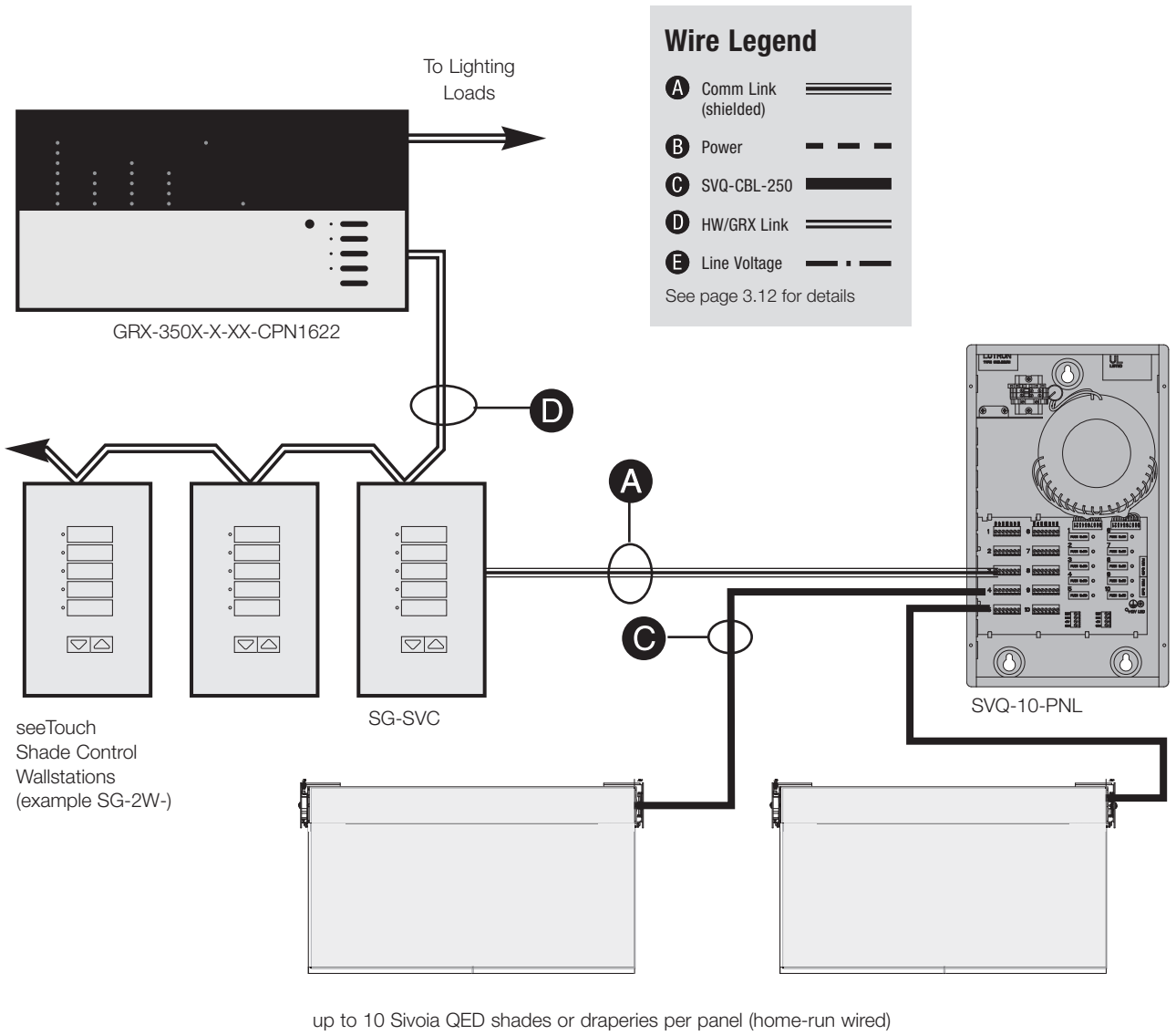

System Maximums	Zones	Main Units	SG-SVC Controls	GRX Accessory Controls*
GRAFIK Eye 3000	48	8	8	16





*Note: GRX Accessory Controls include standard scene selection wallstations, shade control wallstations, and control interfaces.

GRAFIK® 3000 | detail

More than three SG-SVC controls wired to a GRX-3000 wallstation requires the use of a GRX-12VDC class-2 transformer (120V: 12VDC).

INTEGRATION

Wire Legend

- A** Comm Link (shielded) 
 - B** Power 
 - C** SVQ-CBL-250 
 - D** HW/GRX Link 
 - E** Line Voltage 
- See page 3.12 for details

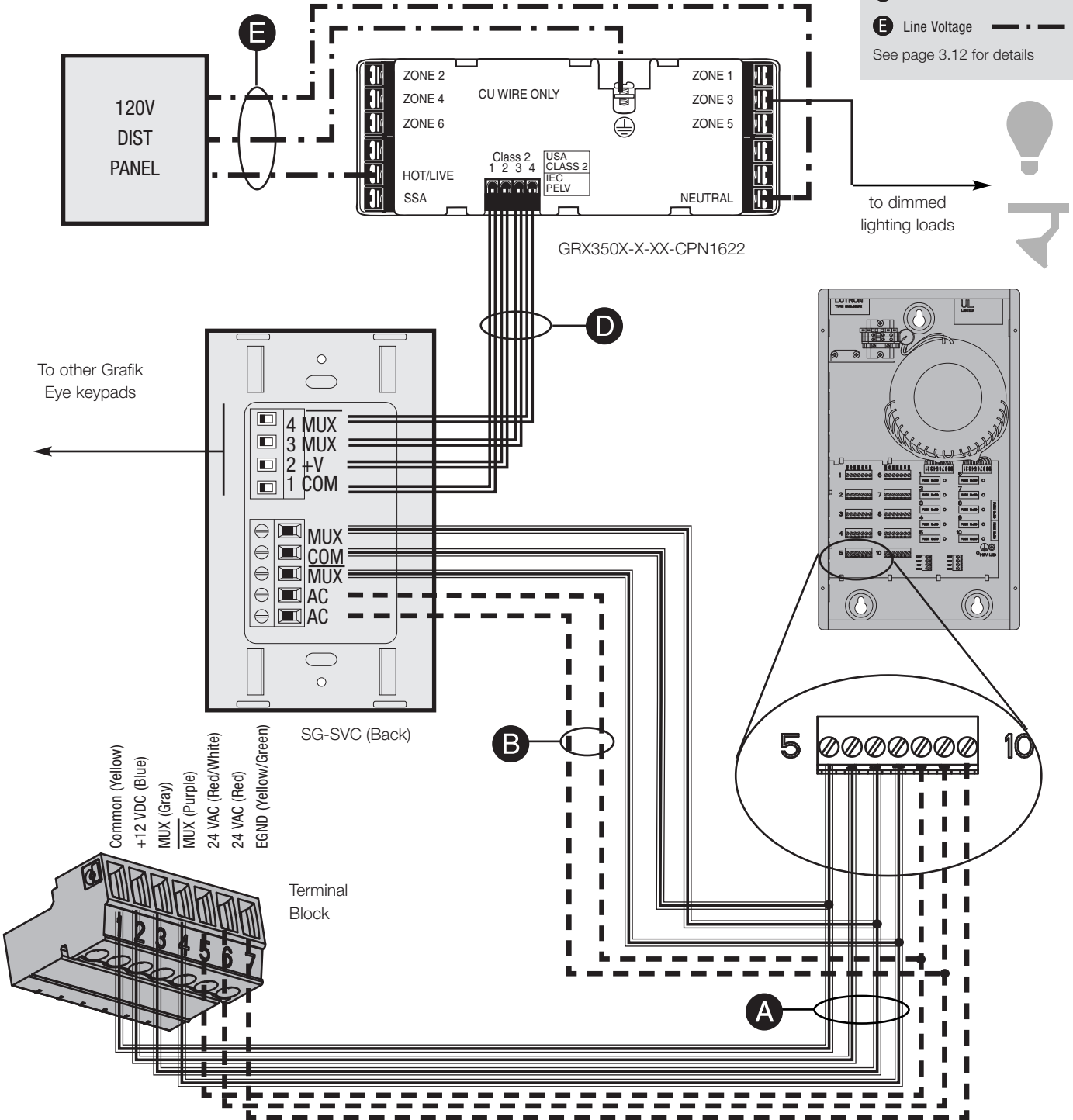

GRAFIK® 3000 | multiple SG-SVC controls

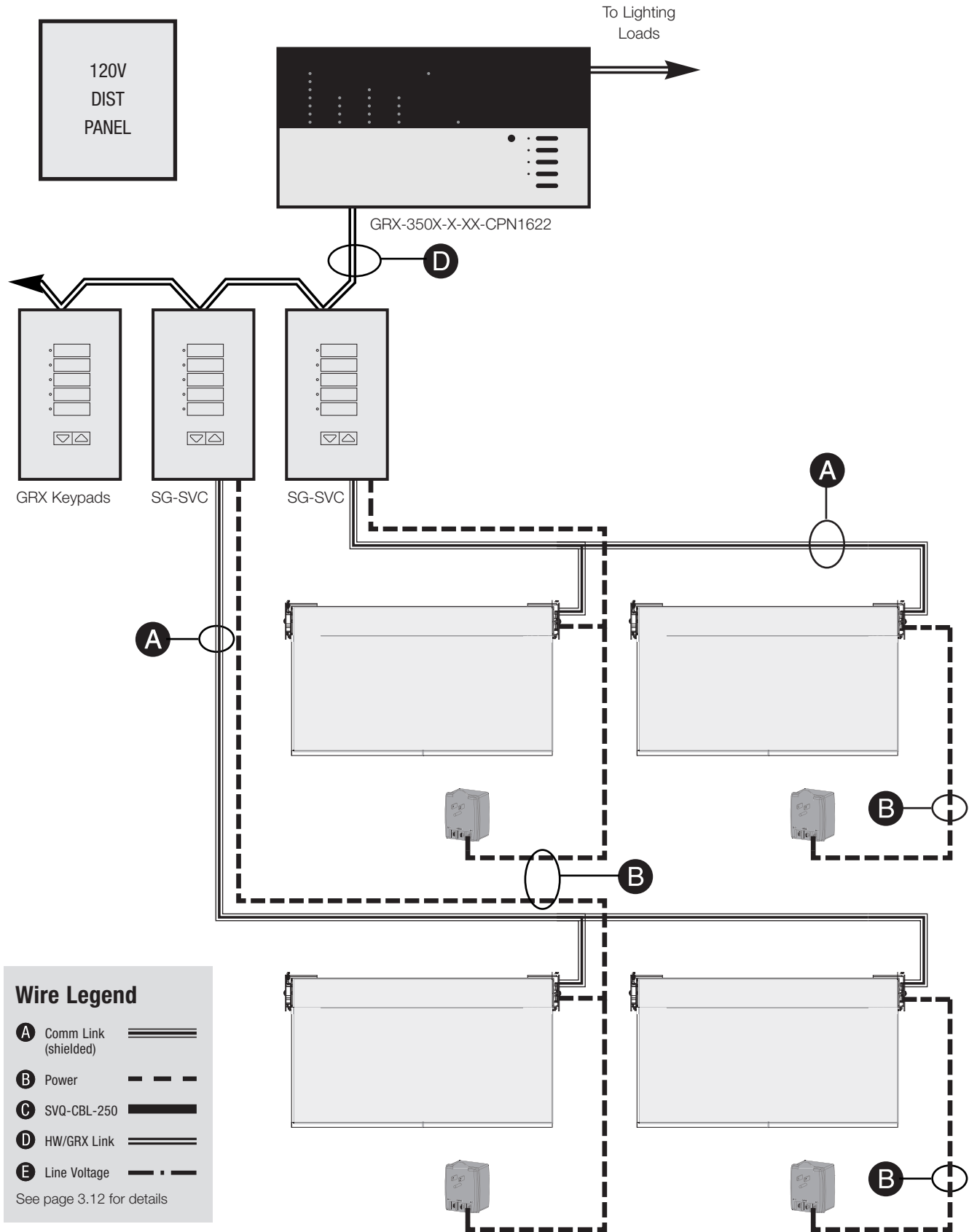

GRAFIK® 4000 | overview

INTEGRATION

Sivoia EDUs can be controlled directly from the GRAFIK 4000 wallstation by using the SG-SVC control. The SG-SVC coordinates the movement of Sivoia EDUs with lighting controls in preset scenes on the GRAFIK Eye®. One SG-SVC is required per group of shades moving in unison. A maximum of eight SG-SVC controls can be employed with a GRAFIK 4000 system. The SG-SVC will operate all window treatments on the Sivoia QED link.

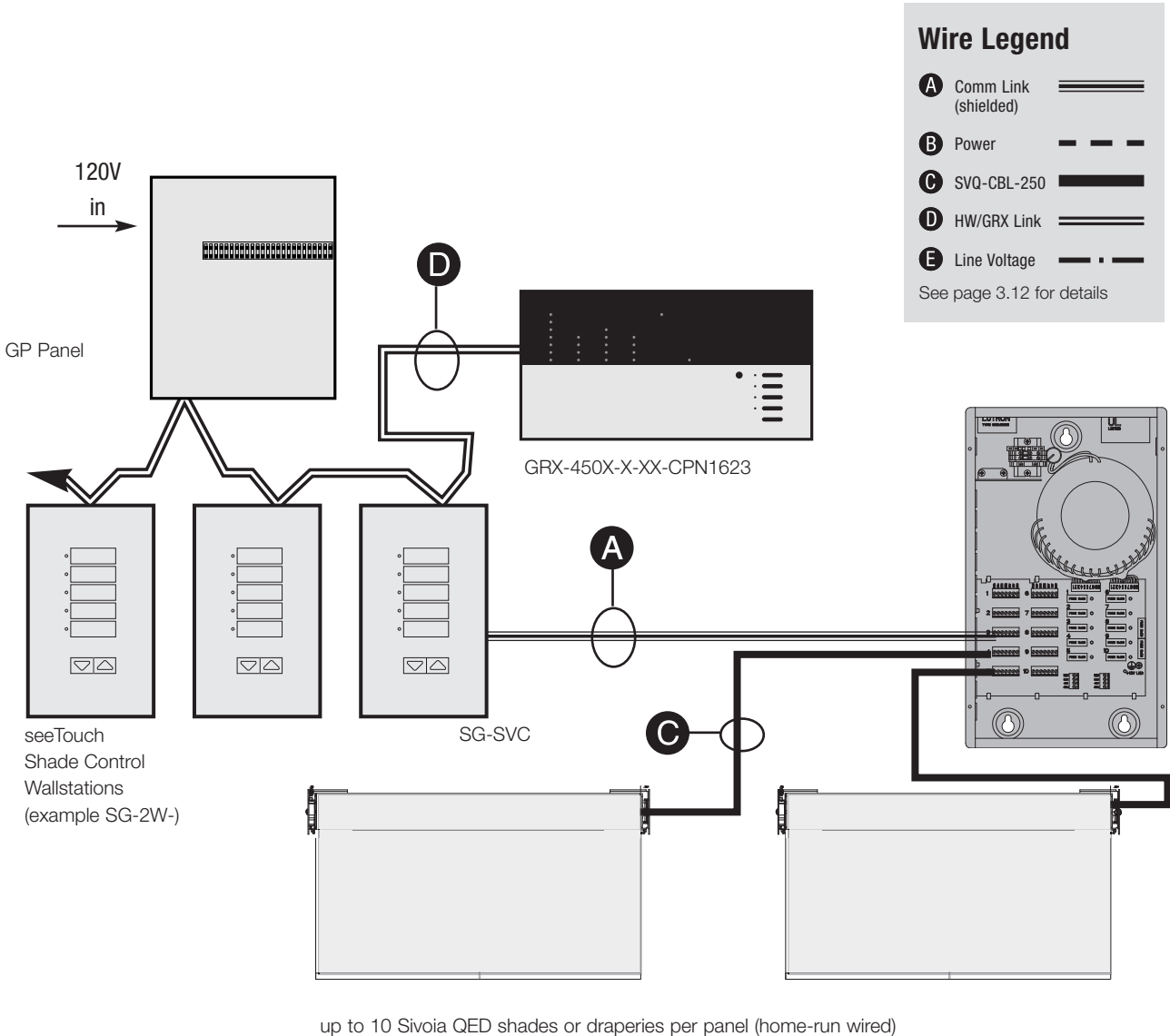

System Maximums	Zones	Main Units	SG-SVC Controls	GRX Accessory Controls*
GRAFIK Eye 4000	64	8	8	16

*Note: GRX Accessory Controls include standard scene selection wallstations, shade control wallstations, and control interfaces.

GRAFIK® 4000 detail

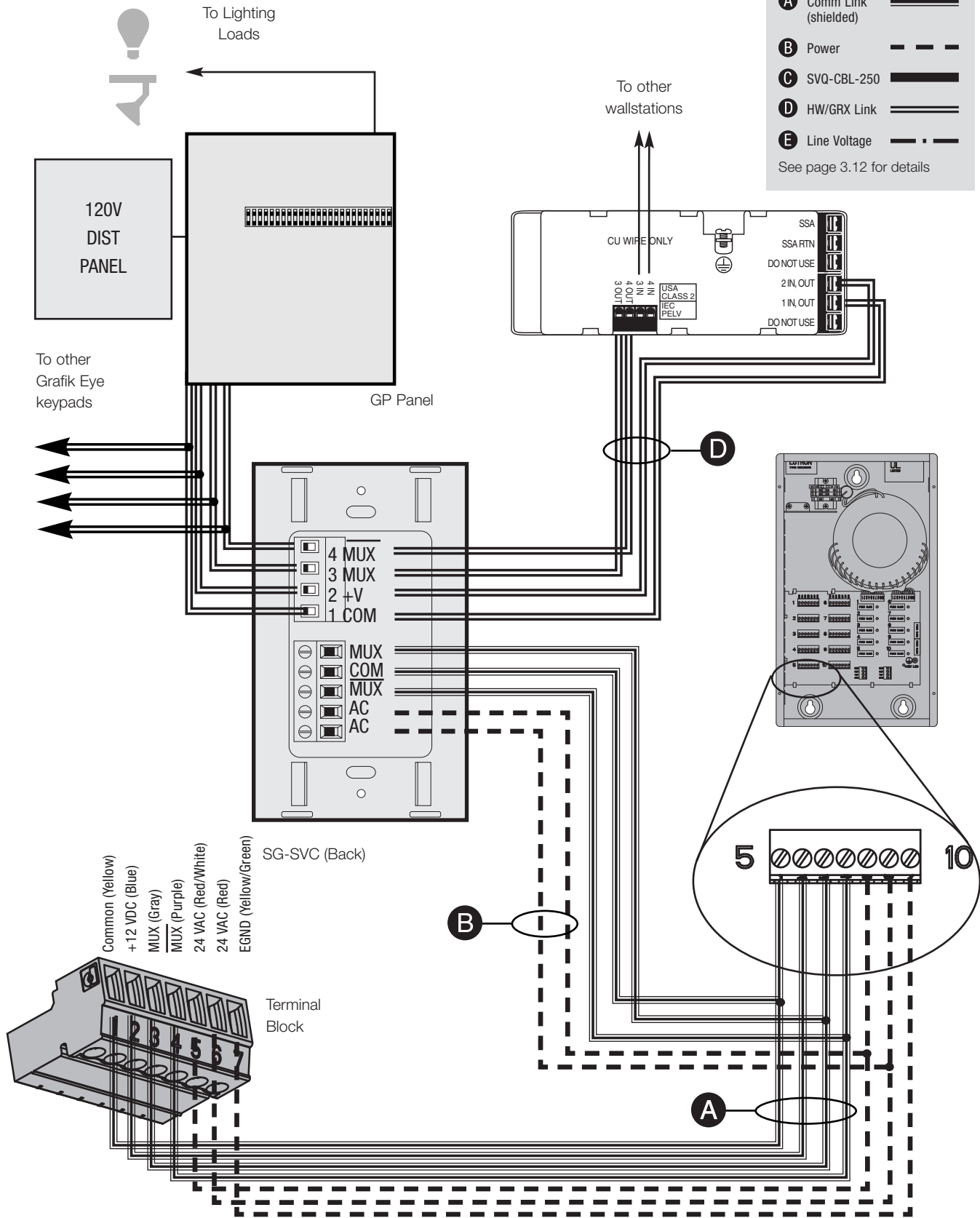



GRAFIK® 5000/6000/7000 | overview

INTEGRATION

Sivoia QED EDUs can be controlled directly from the GRAFIK 5000 or 6000 control systems by using the SO-SVC control. The SO-SVC coordinates the movement of Sivoia QED EDUs with lighting controls in preset scenes in the GRAFIK system throughout an entire building or campus of buildings. One SO-SVC is required per group of shades moving in unison. Each SO-SVC occupies one address on a wallstation link.

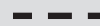
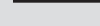
Wire Legend

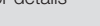
- A** Comm Link (shielded) 
- B** Power 
- C** SVQ-CBL-250 
- D** HW/GRX Link 
- E** Line Voltage 

See page 3.12 for details

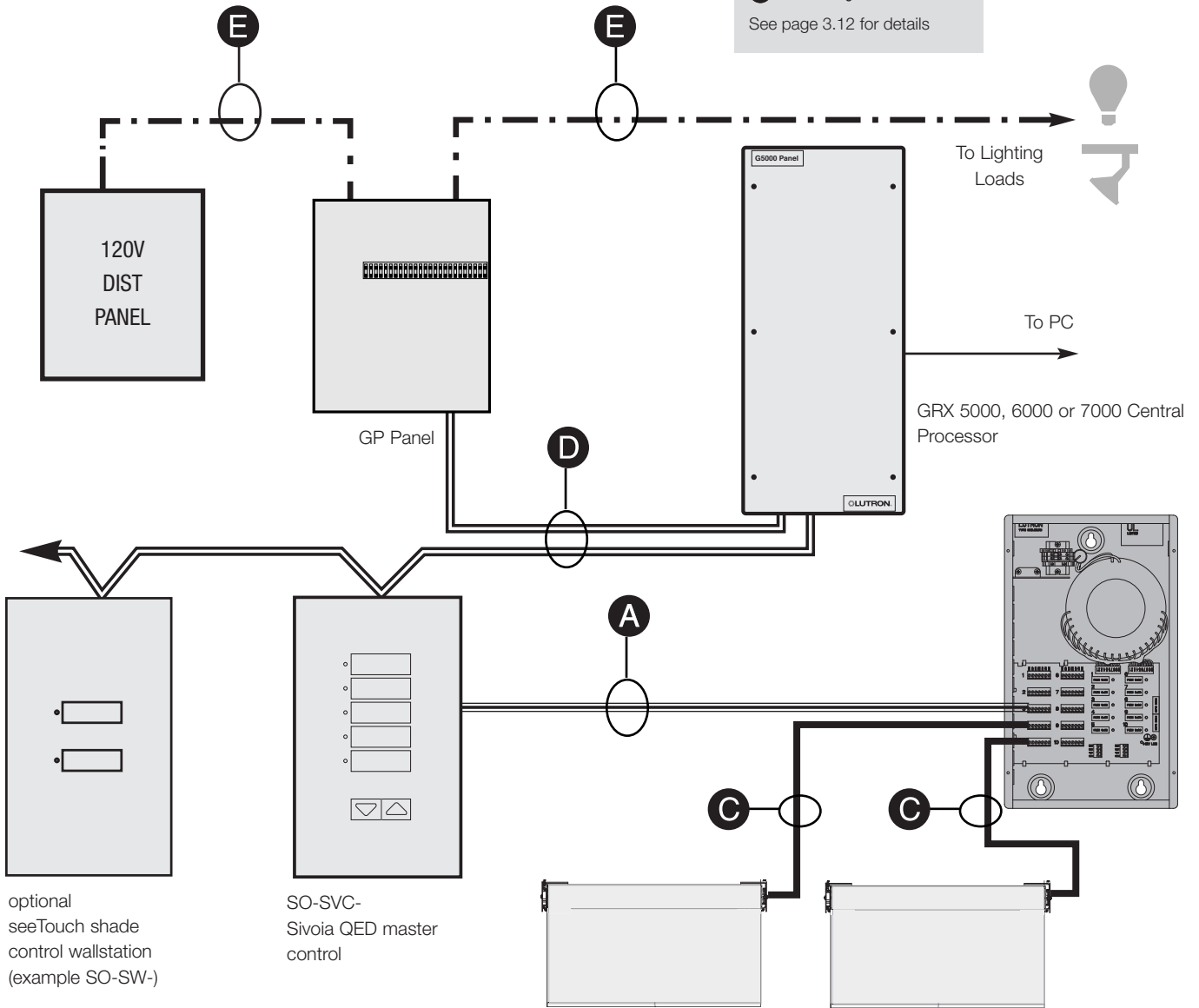

optional
seeTouch shade
control wallstation
(example SO-SW-)

SO-SVC-
Sivoia QED master
control

up to 10 Sivoia QED shades or draperies per
panel (home-run wired)

RadioRA® | overview

Sivoia QED EDUs can be controlled directly from the RadioRa radio-frequency whole-home lighting control system by using the RA-SVC control. The RA-SVC coordinates the movement of Sivoia QED EDUs with lighting by receiving a control signal from a RadioRA Master Control via an RF signal repeater. The signal repeater must be installed within 30' of the RA-SVC control.

INTEGRATION

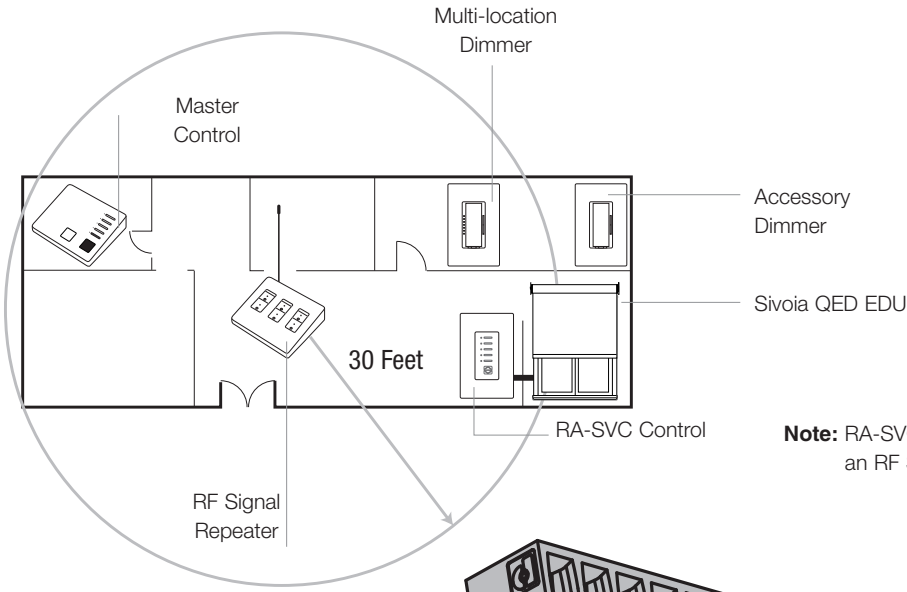

Note: RA-SVC controls must be located within 30 feet of an RF Signal Repeater.

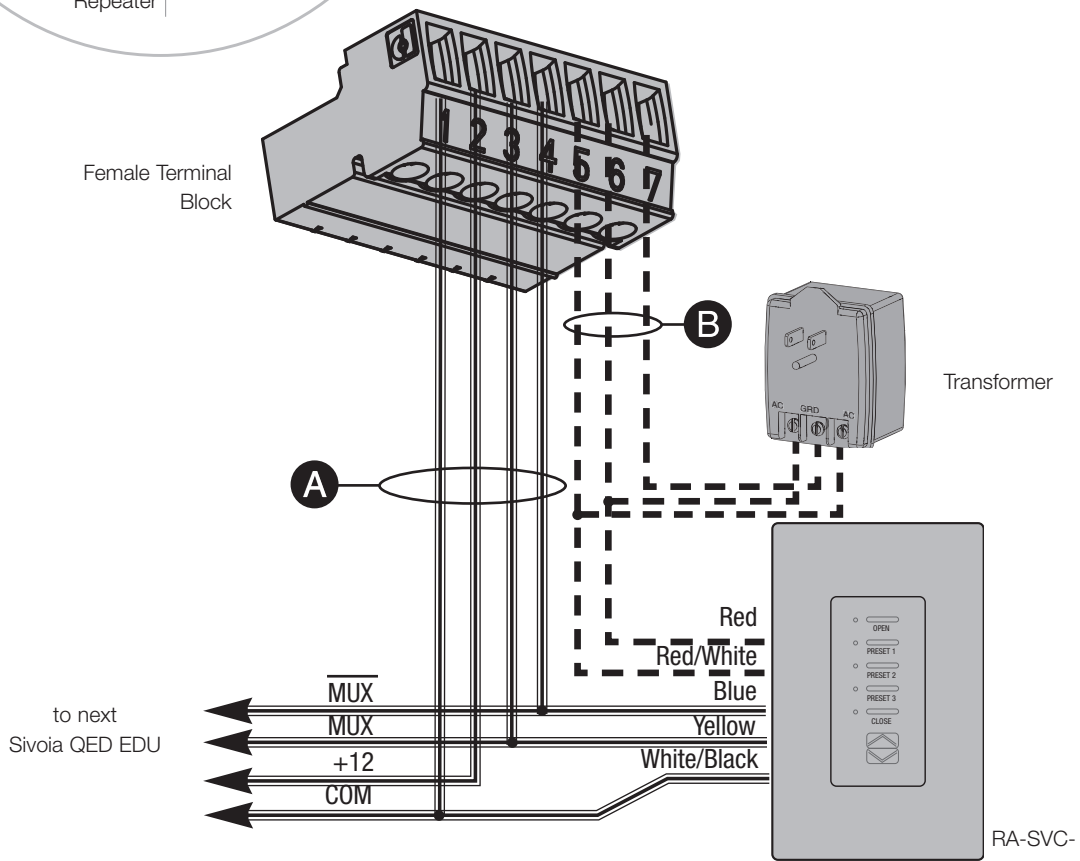

RadioTouch™ overview

INTEGRATION

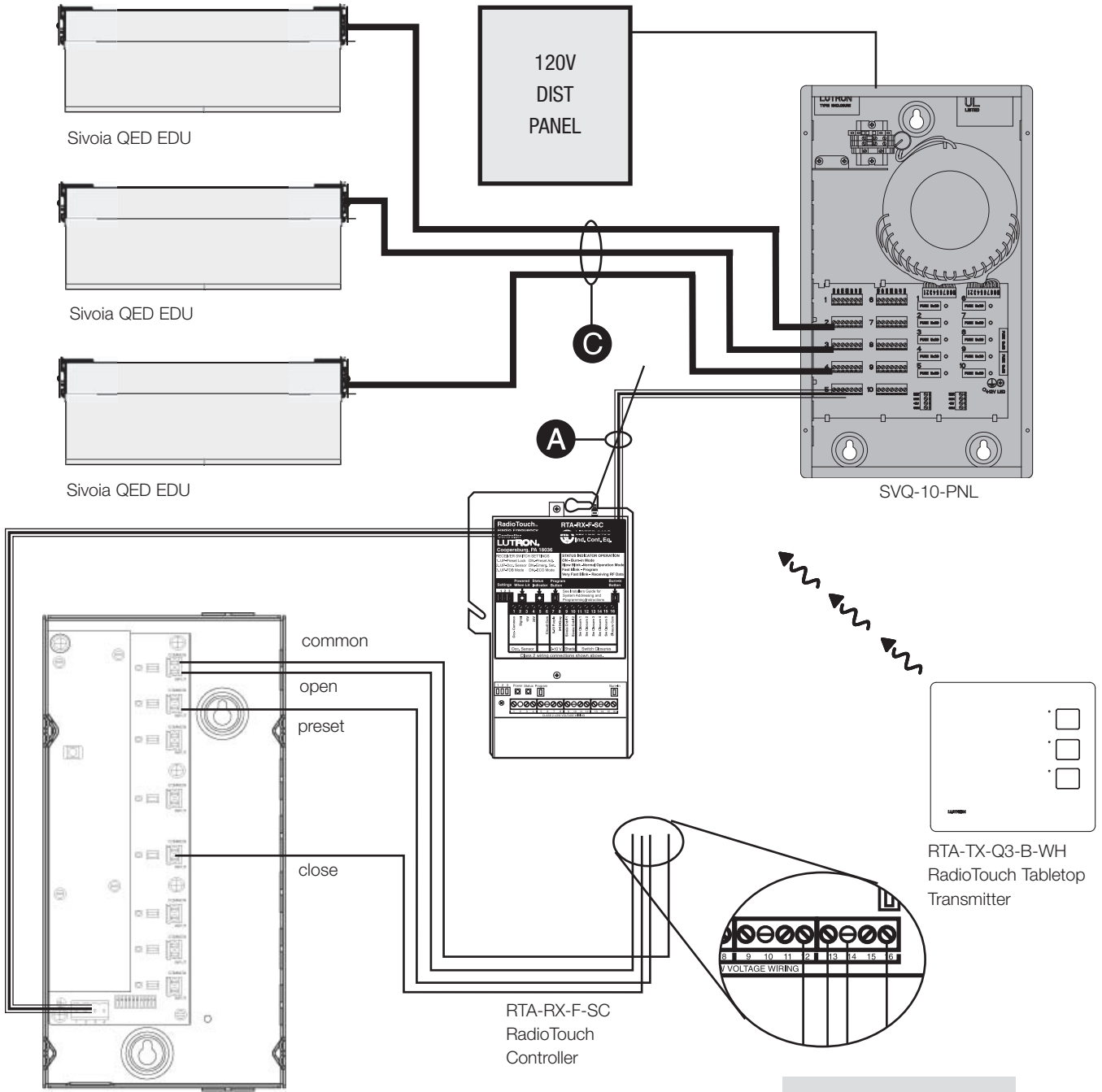

SVQ-CCI-8
Sivoia QED Contact
Closure Input

Note: Use RTA-WX-Q3LB-WH wallbox transmitters.
Use any tabletop transmitter with a "Q" in the
model number.

Wire Legend

- A** Comm Link (shielded)
- B** Power
- C** SVQ-CBL-250
- D** HW/GRX Link
- E** Line Voltage

See page 3.12 for details

5 | drapery track systems

introduction

- Sivoia QED draperies are designed for use with pinch-pleat fabrics.
- The Sivoia QED drapery wiring is identical to other Sivoia QED systems.
- Standard Sivoia QED controls, interfaces and transformers can be used with the Sivoia QED Drapery system.
- The Sivoia QED drapery system interfaces to Lutron and other manufactures equipment in the same manner as other Sivoia QED shade systems.
- The programming is identical to other Sivoia QED products.
- The drapery carriers can be loaded and unloaded without disassembly.

straight track configurations

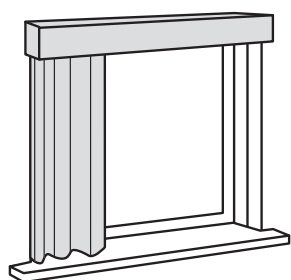

Left draw/ Left-Mounted EDU

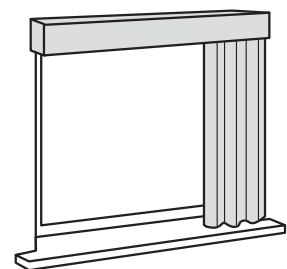
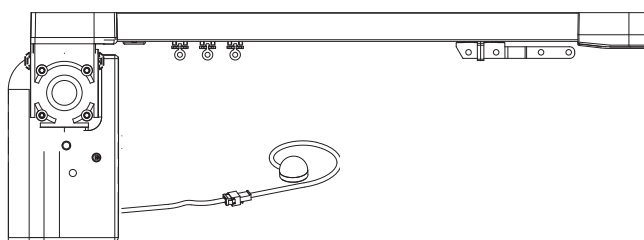

Right draw/ Right-Mounted EDU

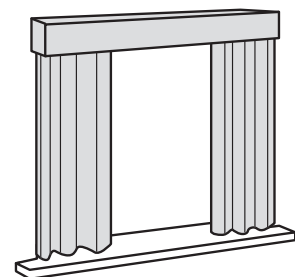
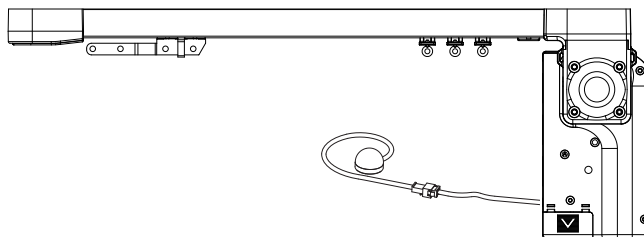

Split-Draw, Left- or Right-Mounted EDU

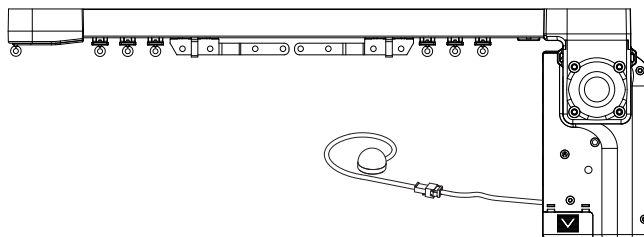

straight track configurations

One Way Draw (left or right stack available)

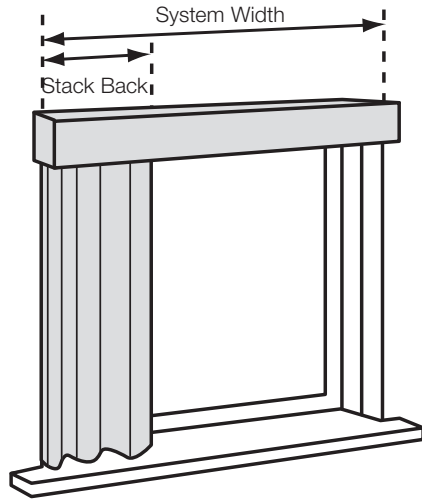

Max System Width = 18.0 feet
Stack back = 1/3 System Width
Drapery Speed: 6 in/sec

SPLIT DRAW

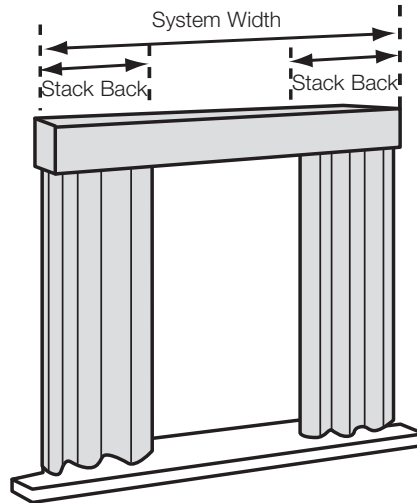

Max System Width: 18.0 feet (see two-motor systems for wider widths)
Stack back = 1/6 System Width on each side (1/3 total)
Drapery Speed: 6 in/sec
Specify the motor side when ordering a center-open system

straight track capacity

Drapery materials and construction techniques vary widely. The size of the drapery that can be used with the Sivoia QED drapery track depends primarily on the total fabric weight of

the draperies being used. Weight of a drape (weight given includes face fabric, lining and top bottom and side hems based and is calculated based on a fullness of 2.5:1).

Typical Sheer Drapery-
4 - 6 oz/square yard

Typical Blackout Drapery with Lining-
12 - 16 oz/square yard

Height	4 oz / square yard Total fabric weight	12 oz / square yard Total fabric weight	16 oz / square yard Total fabric weight	24 oz / square yard Total fabric weight
72.0" tall	Up to 18.0' wide	Up to 18.0' wide	Up to 15.0' wide	Up to 12.0' wide
96.0" tall	Up to 18.0' wide	Up to 18.0' wide	Up to 15.0' wide	Up to 7.0' wide
144.0" tall	Up to 18.0' wide	Up to 14.0' wide	Up to 9.0' wide	N/A

maximum fabric weight capacities for straight tracks

Use this chart to determine the maximum fabric weight the Sivoia drapery system can operate, based upon system width.



Single EDU System

Width	3'-9'	10'-13'	14'-18'
Weight (lbs)	80	70	60

Tandem Two-Drive System

Width	6'-18'	19'-26'	27'-36'
Weight (lbs, for both panels)	160	140	120

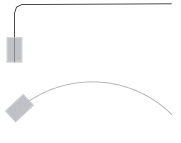
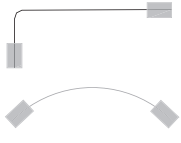
curved track capacity

Standard Options					
Number of Bends	4'-9' System Width	9'-18' System Width	One Way	Split Draw	Limitation
	Maximum Fabric Weight (lbs)		Track Layout		
1	40	25			system width >4' system width < 18' curve radius >20"
2*	80	50	n/a		system width >4' system width < 36' curve radius >20"

Custom options vary, contact customer service.

* Requires a two-motor system

mounting hardware

Track Mounting to WALL

Mount the drapery track to the wall using the wall mount "L" brackets. Mount the brackets using the spacing illustrated below. Mount each end bracket 6 inches from each end of the track. Space the next bracket on both sides 16" from the end brackets. Space the remaining brackets 16-24" apart. **Mount into studs everywhere possible. Use appropriate hardware.**

Assembled Isometric View

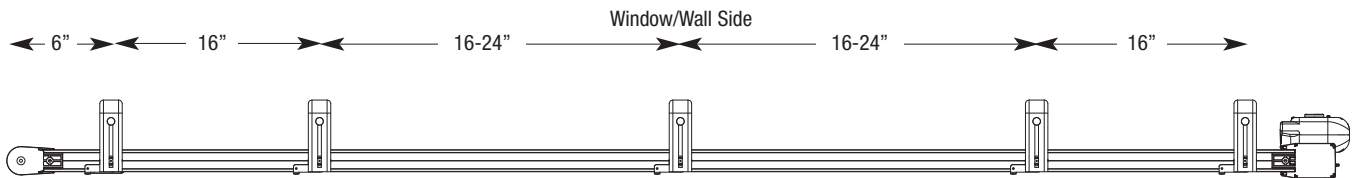

Wall-Mounted Bracket

The wall-mounted bracket provides variable adjustment from 4.50 - 6.75 inches from the mounting surface. Cam locking clips are used to attach the brackets to the track as shown in the assembled side view below.

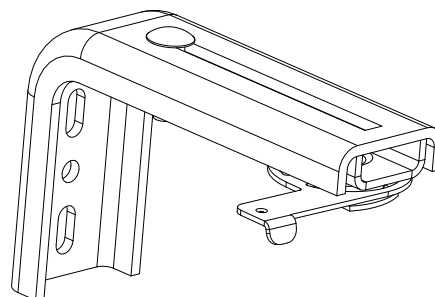

mounting hardware

wall-mounted bracket
assembled side view

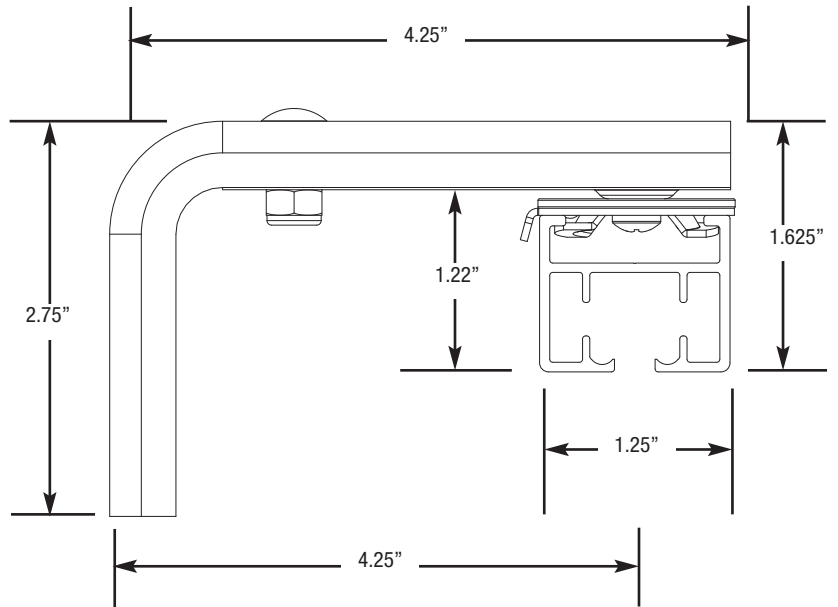

Extended bracket
assembled side view

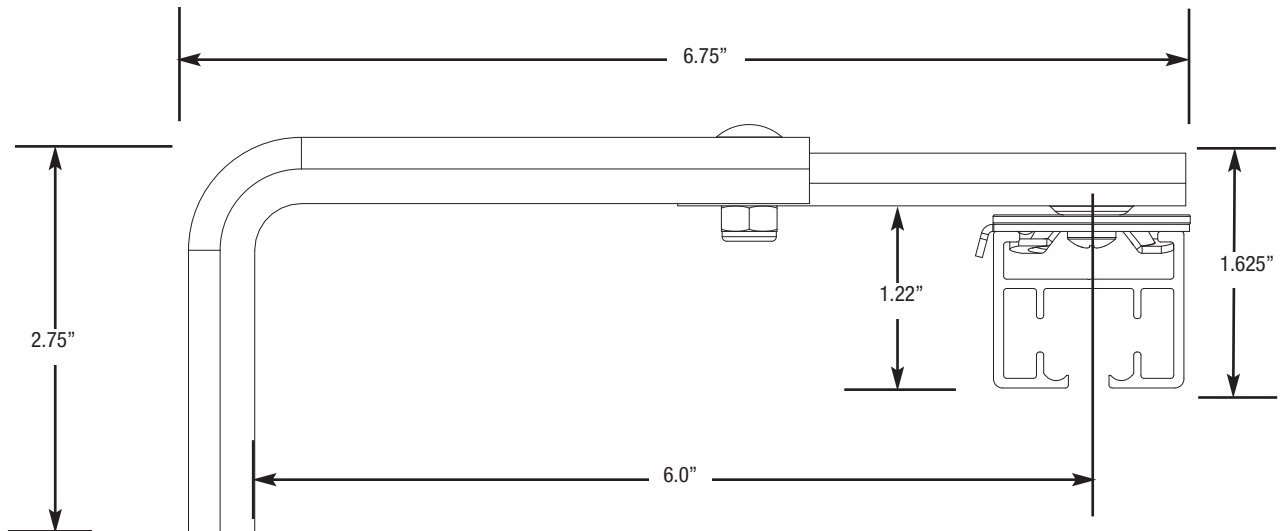

DRAPERY TRACK SYSTEMS

mounting hardware

Wall-Mounted Bracket Dual-mount - assembled side view assembled isometric view

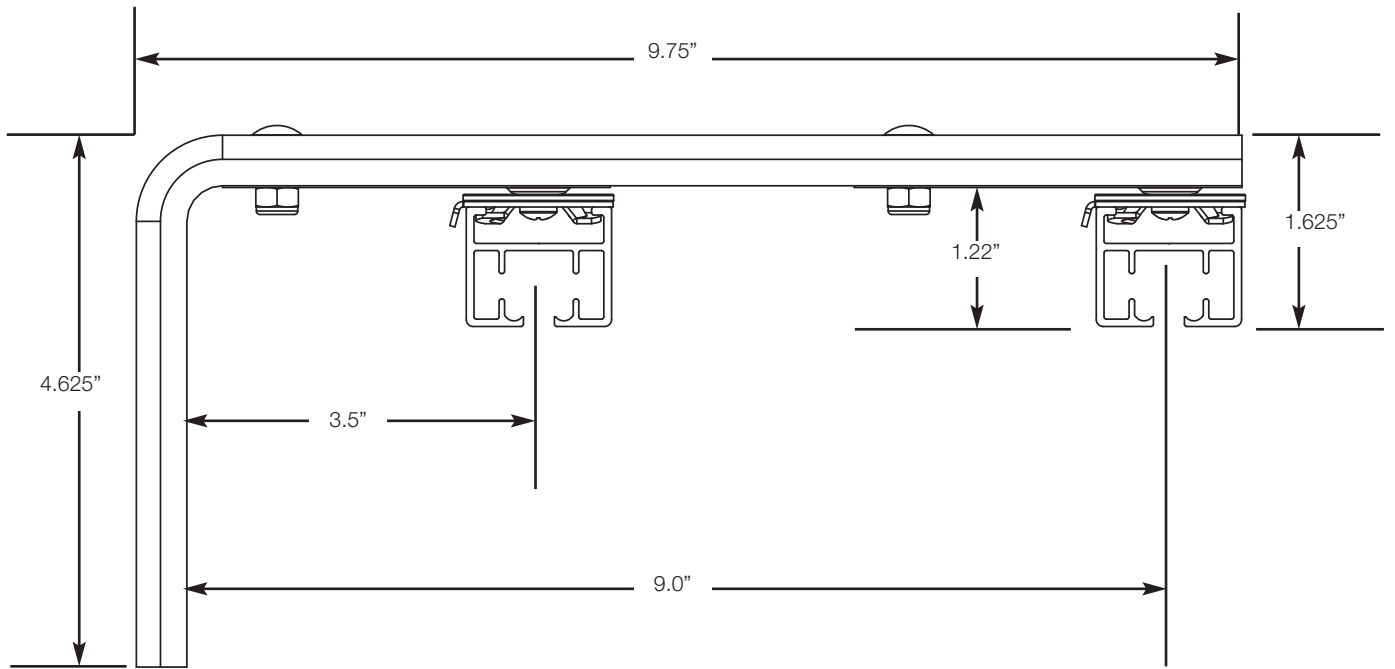

DRAPERY TRACK SYSTEMS

Wall-mounted bracket - Extended dual-mount - assembled side view

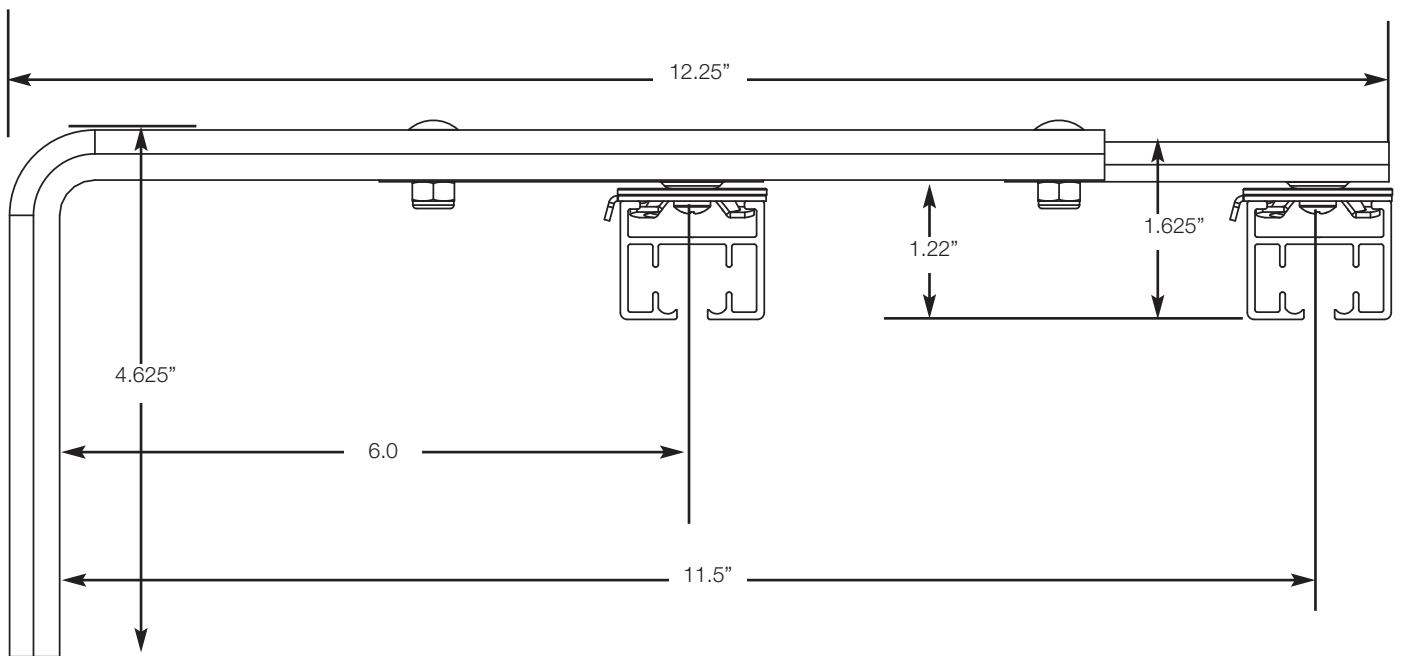

mounting hardware

Track Mounting to ceiling

Mount the drapery track to the ceiling using the cam lock brackets. Mount the brackets using the spacing guidelines shown below. Mount one bracket 6 inches in from each side of the track. Space the next bracket on both sides 16" from the end brackets. Space the remaining brackets 16-24" apart. **Mount into studs everywhere possible. Use appropriate hardware.**

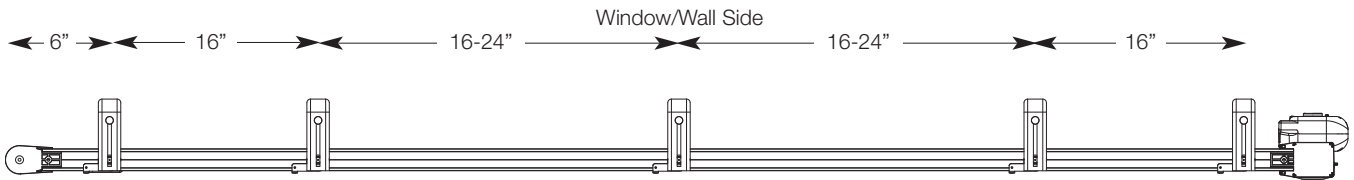

DRAPERY TRACK SYSTEMS

ceiling-mounted bracket

The ceiling mount option uses only the locking clip screwed directly to the ceiling mounting surface.

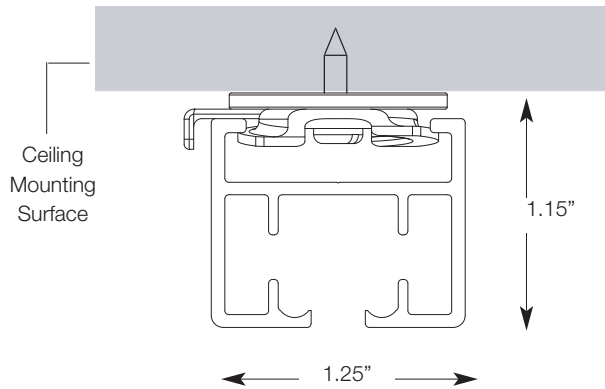

ceiling-mounted bracket - Exploded view

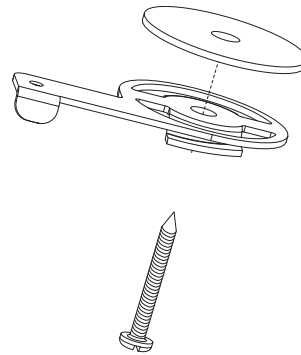

Top view of clip arm extended in unlocked position

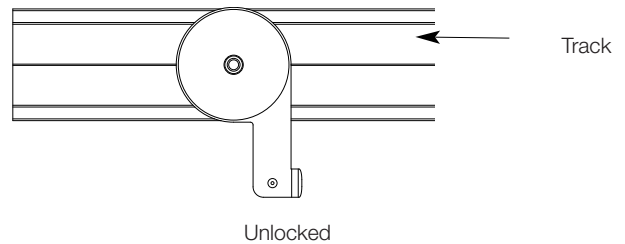

measuring

System width

- Installed drapery covers both end caps so the track width equals the full system width as shown below.

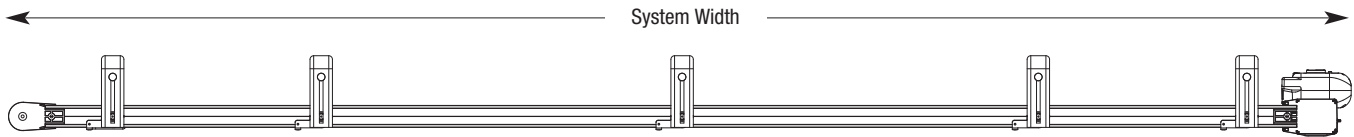

Measuring for minimum recommended overlap

- Determine the width of the system required for your application by measuring the widest part of your window opening. Draperies should overlap the window you are treating in most cases by a minimum of three inches on each side. When using the minimum overlap, the stack back of a fully-open drapery will cover a portion of the window area.

Measuring for complete window reveal

- To completely reveal a window when the drapery is open the stack back on the drapery must be considered. Consult stack diagrams for stack back dimensions.
- In addition be aware that depending on the construction and material the drapery will be slightly wider at the bottom than at the top.

left or right stack

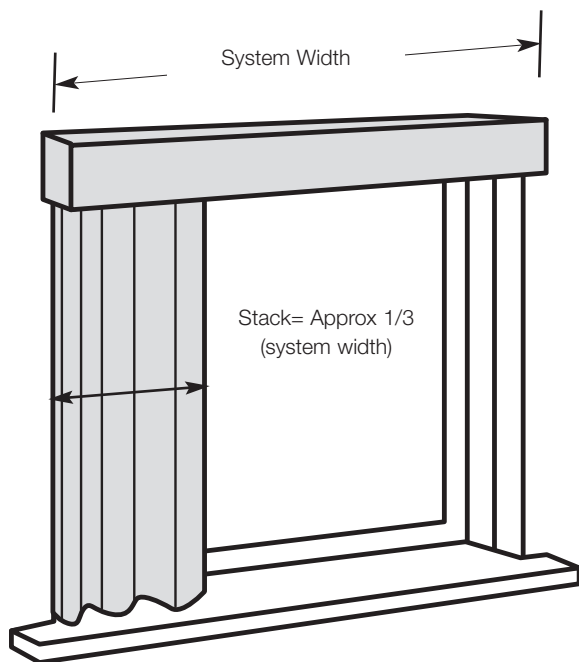

split-draw center stack

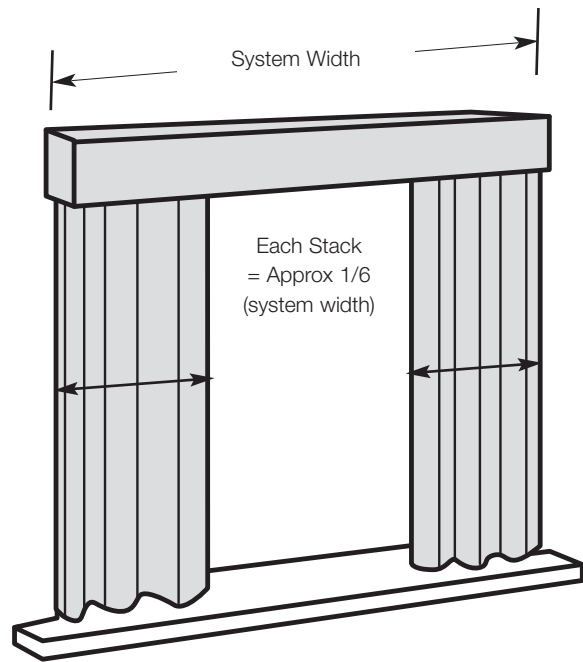

hanging fabric

drapery hook setting

For the best system performance, a drapery hook setting of 1/2 in should be used. This allows the system to operate with minimal noise.

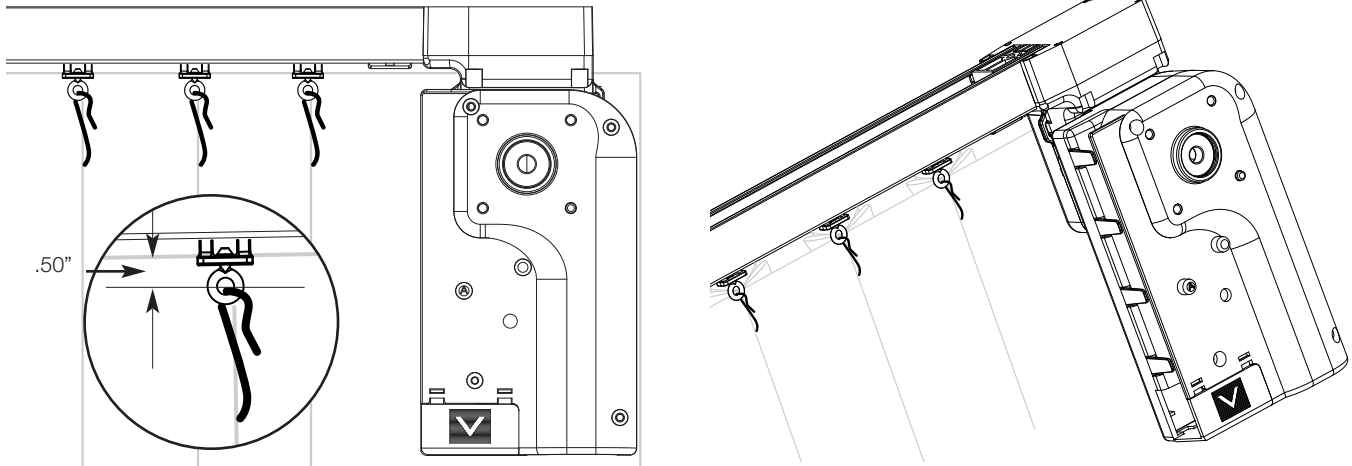

DRAPERY TRACK SYSTEMS

drapery fabric return

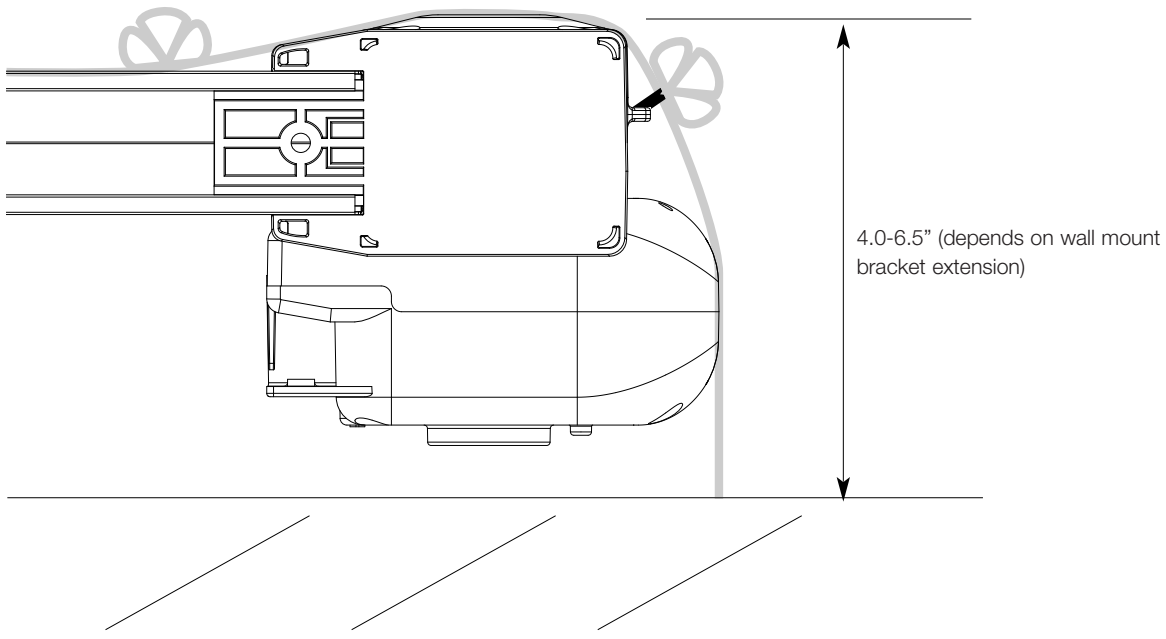



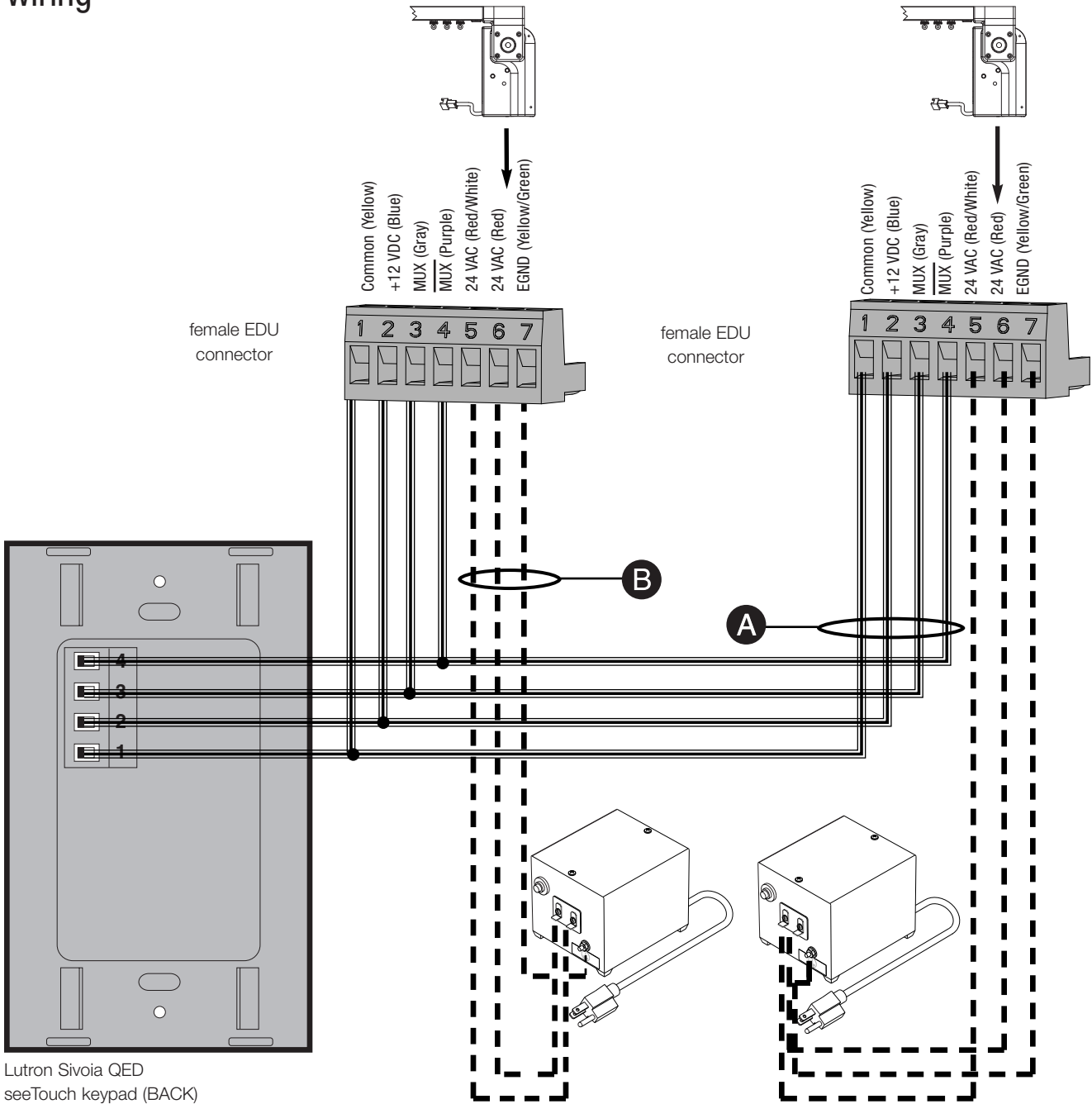

wiring



Lutron Sivoia QED
seeTouch keypad (BACK)

Wire each EDU to a Sivoia QED™ plug-in transformer, junction-box-mount transformer, or a Sivoia QED power panel. Each EDU must be EARTH grounded. Each transformer, of any type, can power ONLY ONE EDU, regardless of shade size.

Wire Legend

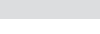
- A** Comm Link (shielded) 
- B** Power 
- C** SVQ-CBL-250 
- D** HW/GRX Link 
- E** Line Voltage 

See page 3.12 for details

system dimensions

Single drapery track

- It is important to maintain enough clearance between the track and the inside face of the top treatment or ceiling recess to allow the fabric to move freely within the top treatment. All measurements shown below are minimums.

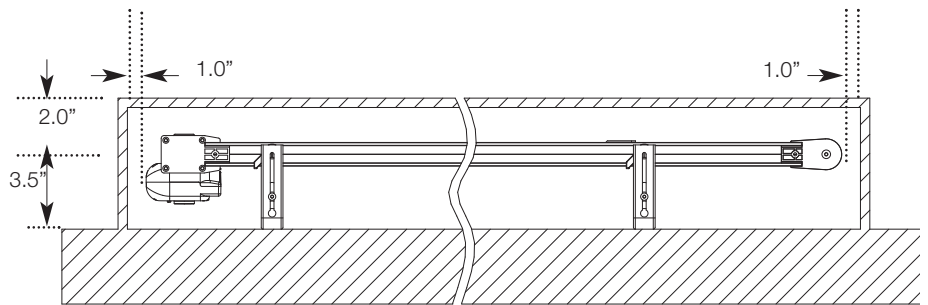
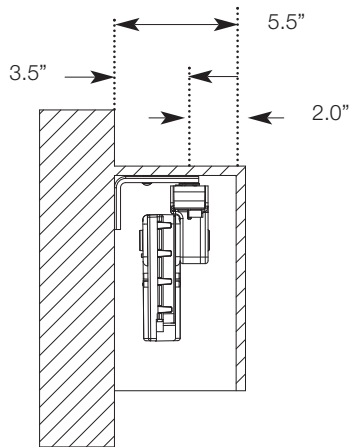

Dual-Mounted drapery track

- Sivoia QED tracks can be used for a combination sheer/blackout treatment. These systems will require more clearance than a single track system.

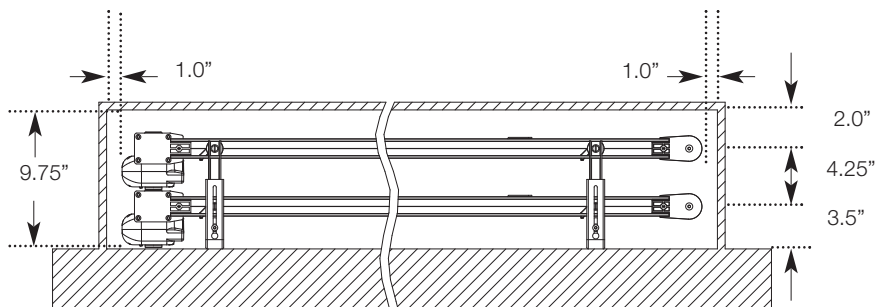
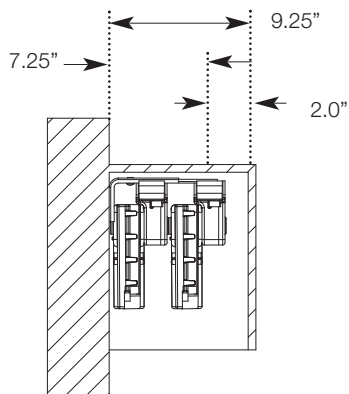

system dimensions

Tandem Two-Drive Drapery Track System

- Unlike standard motorized drapery systems the Sivoia QED™ EDU controls the speed of your draperies with extreme precision. This allows two independent EDUs to be used to create a center-open drapery. All measurements shown below are minimums.

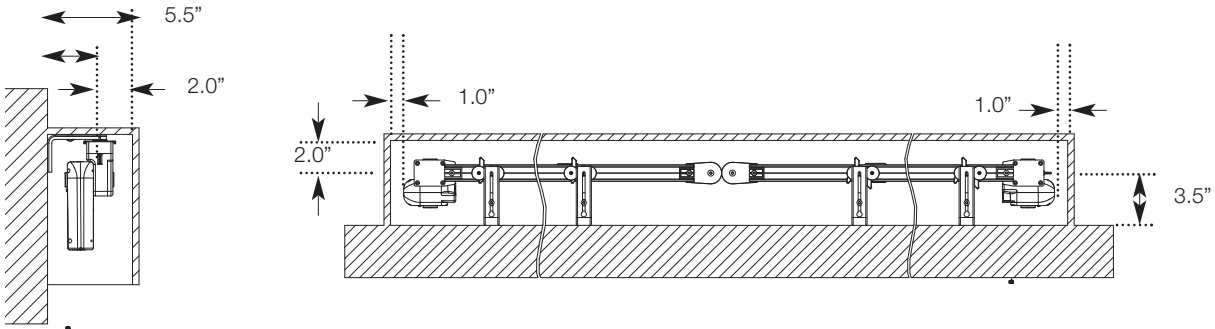

Drapery Track Corner Application

- Sivoia QED drapery systems can be used in corner applications.

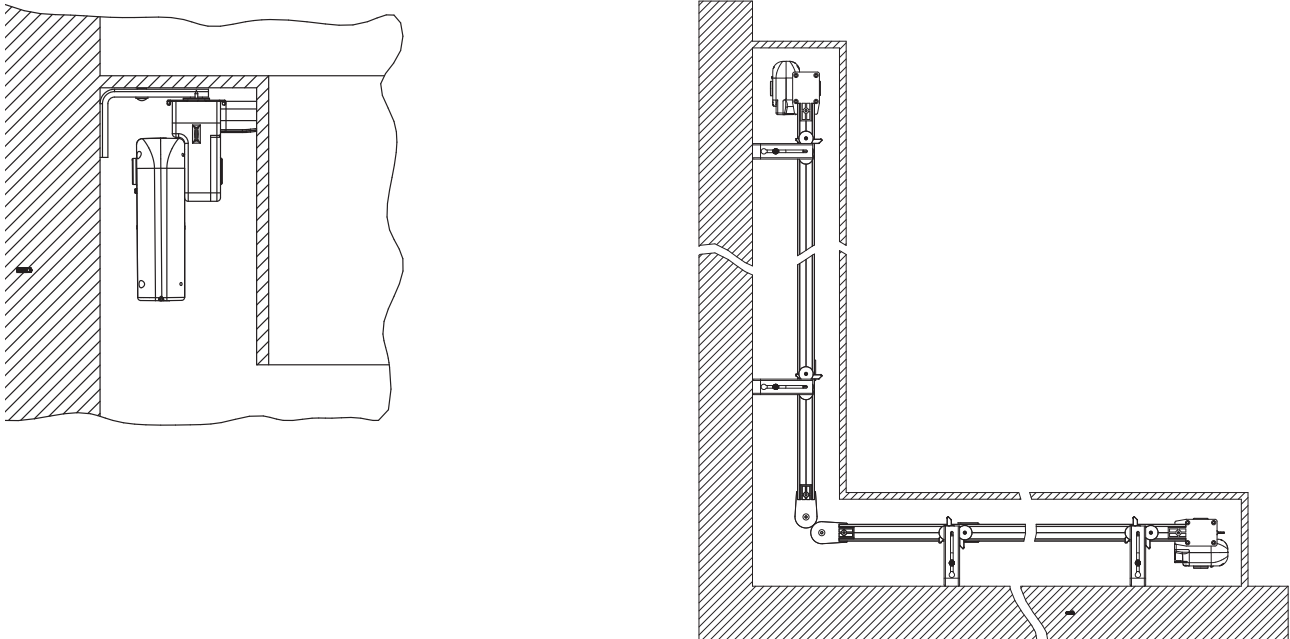

system dimensions

One-way Draw Side View

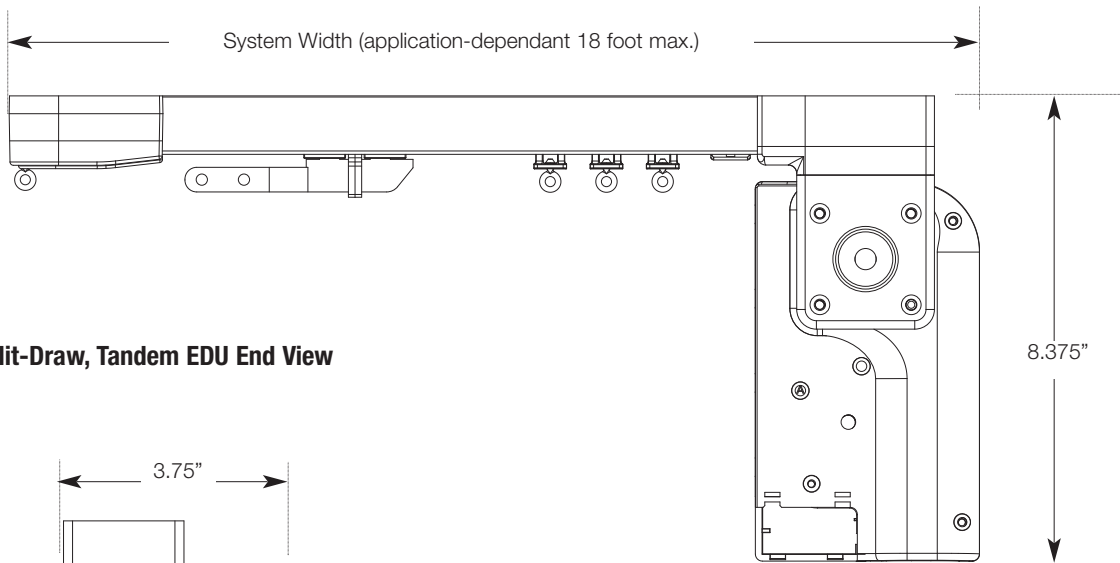

Right, Left, Split-Draw, Tandem EDU End View

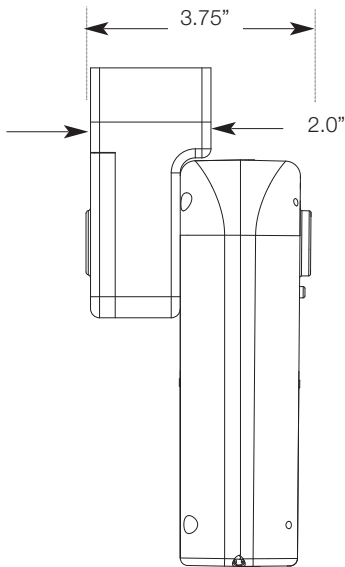

One-Way Draw Top View

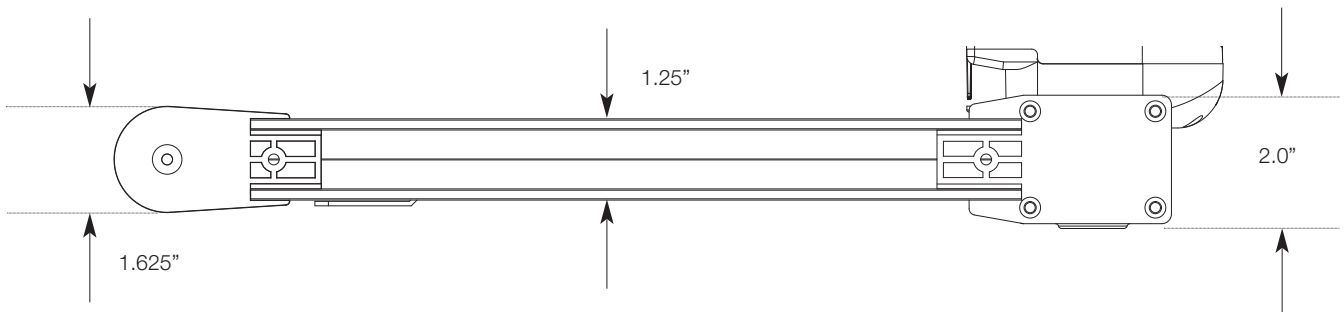

DRAPERY TRACK SYSTEMS

components

Exploded View One Way Draw

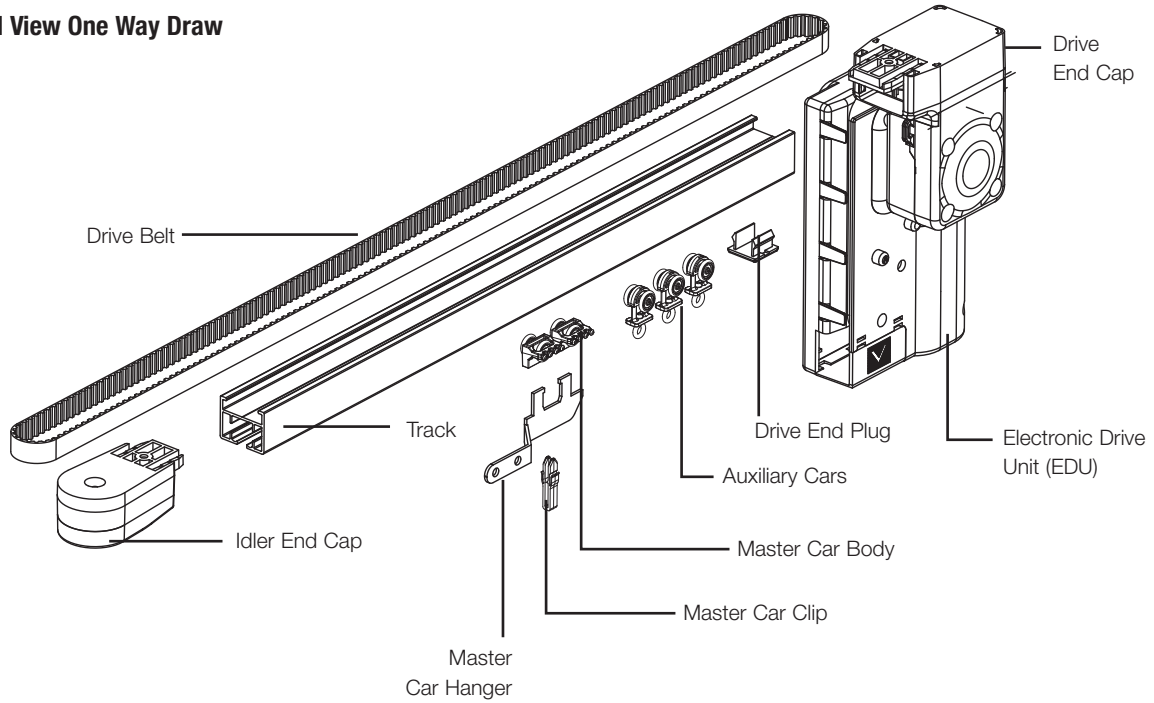

Exploded View Split- Draw

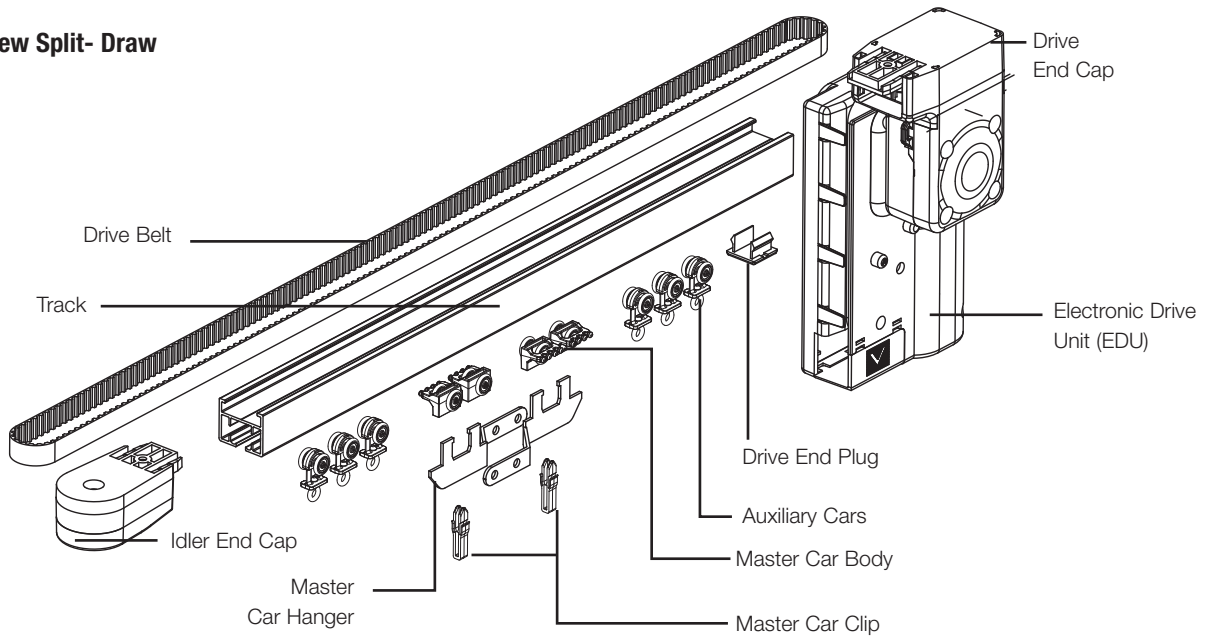

DRAPERY TRACK SYSTEMS

6 | Roman shades

system overview

Sivoia QED™ Roman shades can be configured using two styles of pleats: soft fold and flat-fold. The specifier can choose the height of the pleats for each application.

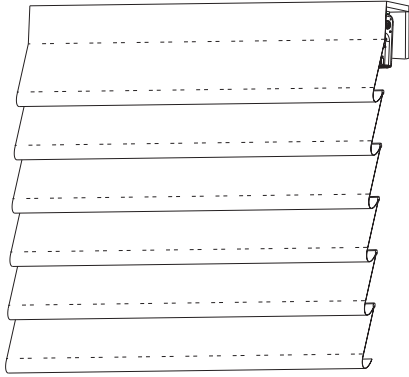

Soft Fold

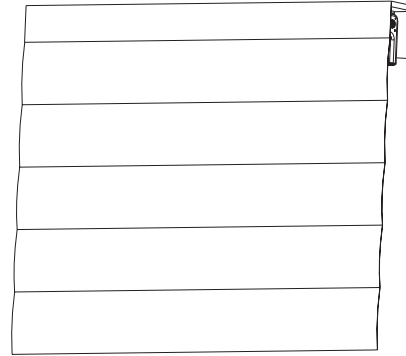

Flat Fold

components

The system is housed within a standard Sivoia top-back cover and mounts with Sivoia bracketry. The cord-rollers are specifically designed by Lutron to operate quietly and smoothly. The system can be inside, outside or recess mounted.

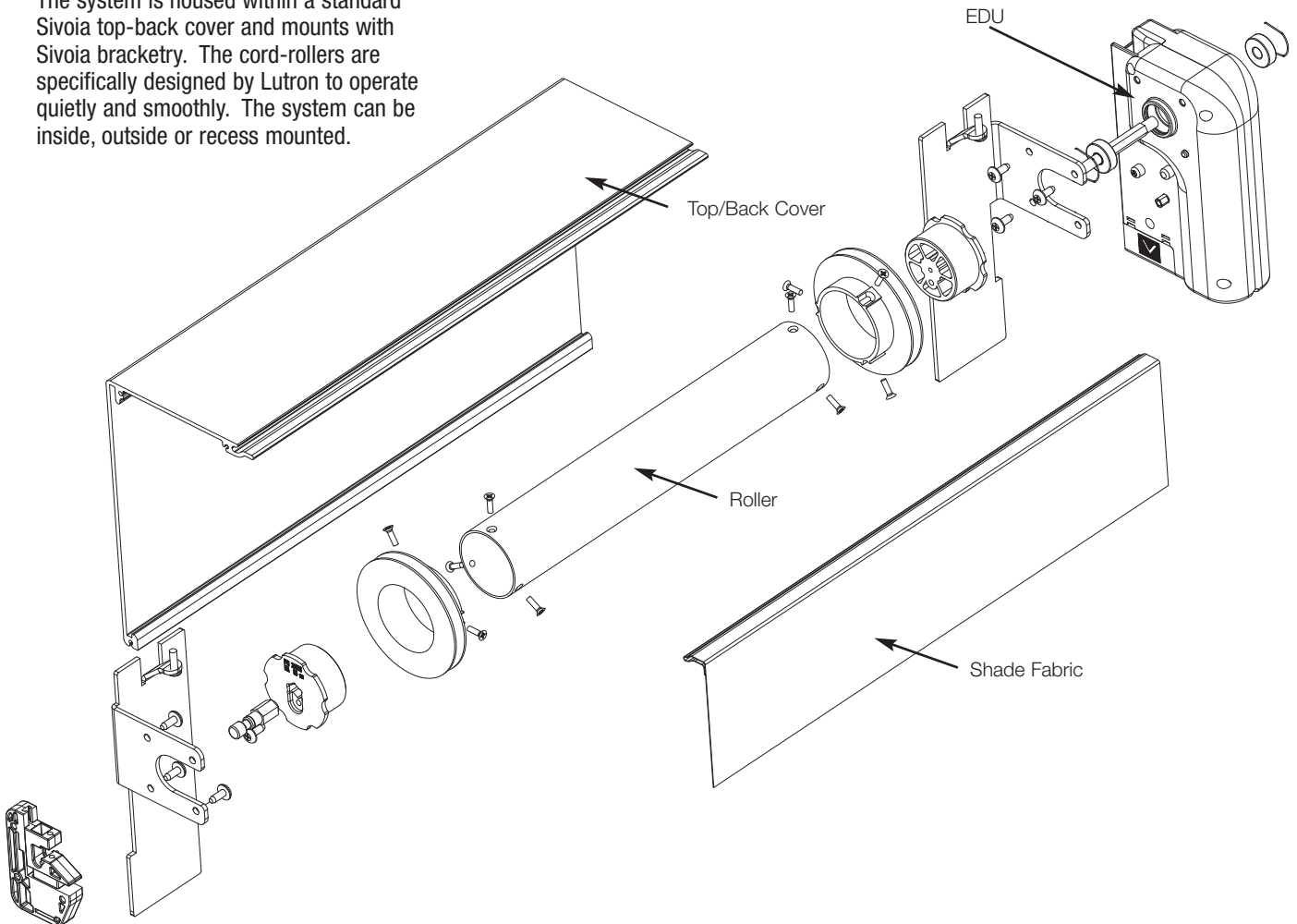

ROMAN SHADES

dimensions

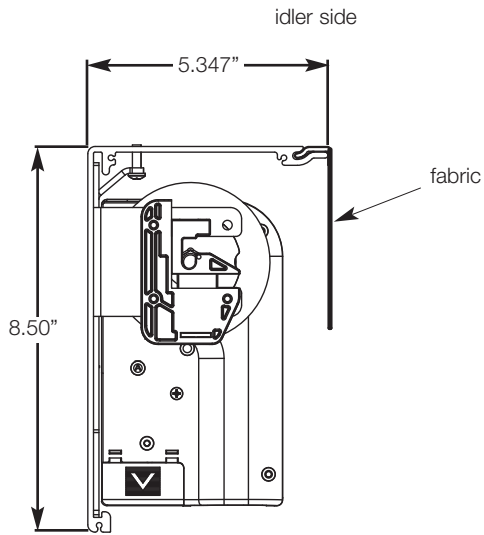

EDU side

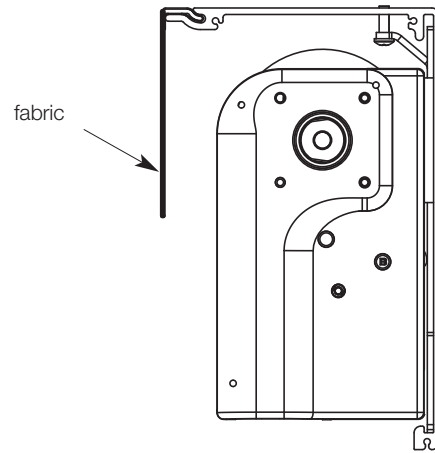

As with the Sivoia QED drapery track, The Sivoia QED Drive Unit is completely hidden from view in any Roman shade solution.

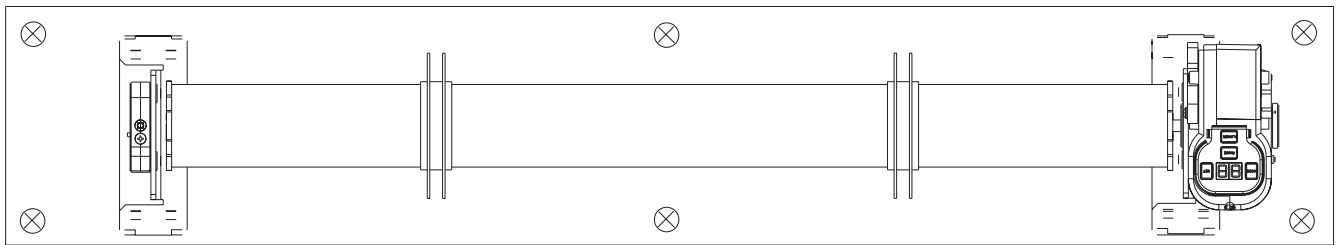

bottom view



elevation

ROMAN SHADES

wiring

- Every keypad, CCI, and EDU is connected by the Sivoia QED™ Communication Link.
- Wire each EDU to a Sivoia QED plug-in transformer, junction-box-mount transformer, or a Sivoia QED power panel. Each EDU must be EARTH grounded.
- Each transformer, of any type, can power ONLY ONE EDU, regardless of shade size.

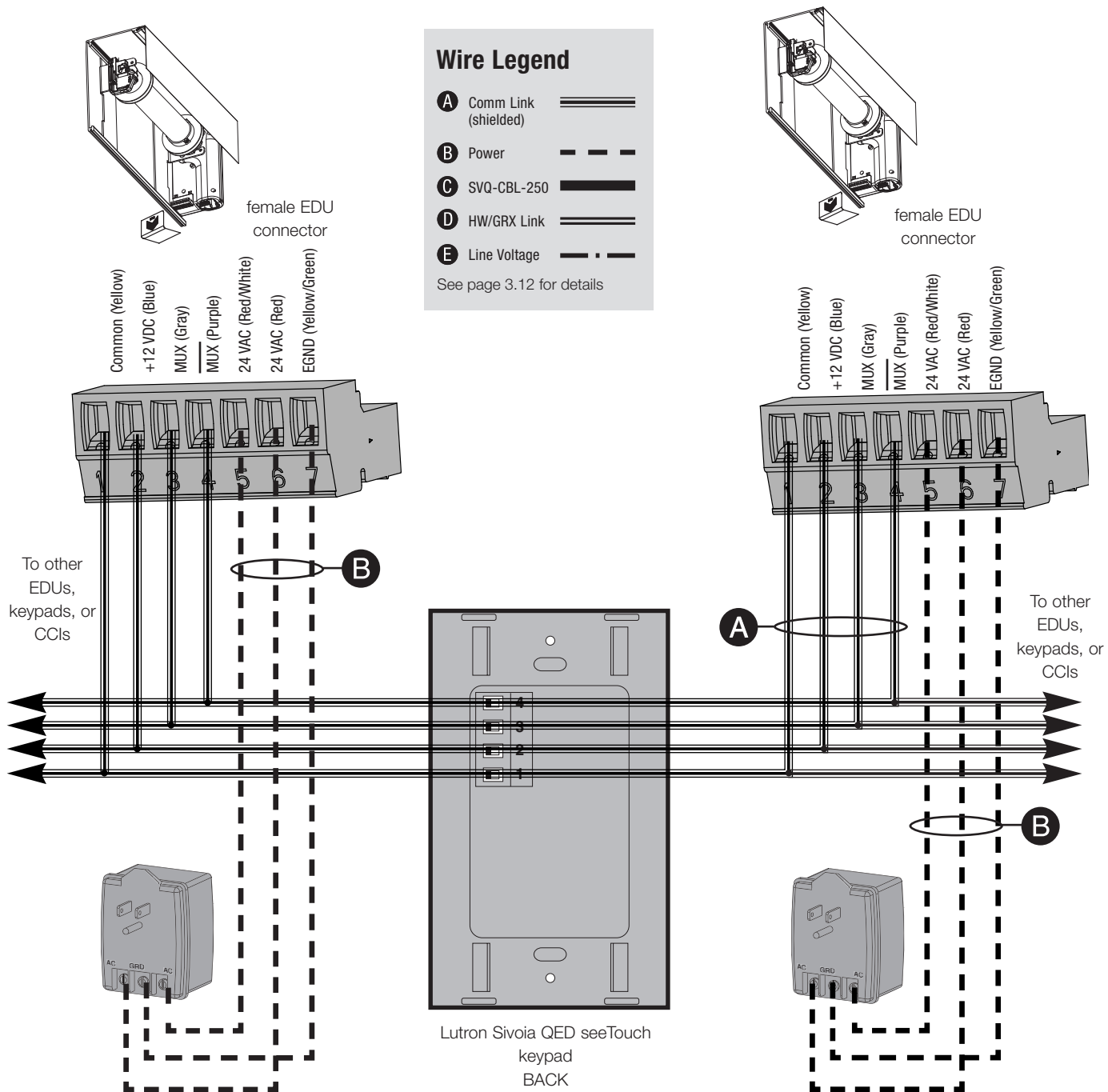

ROMAN SHADES

7 | troubleshooting

troubleshooting

EDU will not move

- EDU is not powered – check EDU power
- Shade fabric is caught on something – Check that shade fabric is not caught on something or binding
- EDU not assigned to keypad, IR transmitter, or CCI

EDU does not fully open or fully close

- Presets have been set incorrectly – try using raise and lower buttons
- Limits have been set incorrectly – refer to "Setting Limits"
- Shade fabric is caught on something – free shade

Shade moves up when pressing lower button, and down when pressing raise button

- Open and close limits have been reversed – refer to "setting limits"

Fabric not level

- Adjust using level adjustment screw
- Check that brackets are mounted level
- Check that fabric is tracking correctly on the shade tube

Fabric not centered over window

- Center shade using center adjustment
- Check that brackets are centered
- Check that fabric is tracking correctly on the tube

Shade does not move smoothly

- Check for binding of shade fabric on side channels, fascia, etc
- Check fabric tracking

Keypad LEDs are off, keypad will not control any shade

- Check that keypad is powered

troubleshooting

Keypad LEDs are lit, but keypad will not operate any shade

- All presets have been set to same height – try using raise/lower buttons at keypad
- Communications Link or IR not wired to EDU – check wiring
- EDU has been un-assigned from keypad – refer to assignment section

Keypads will not operate shade, IR works properly

- Check that keypad is powered
- Keypad not wired correctly – check wiring
- EDU has been un-assigned from keypad. Refer to assignment section
- Presets are all programmed to same location, try using raise/lower at keypad

Can not store presets

- Preset lock enabled
- Presets are being accidentally re-programmed –set presets, enable preset lock

Keypad does not operate all the shades it is assigned to

- EDU has been unassigned from keypad- refer to assignment section
- EDU has all presets set to same height, try raise/lower
- EDU is not wired correctly
- Keypad is not wired correctly

IR controls will not operate shade, keypads work properly

- IR transmitter does not have line of site to IR receiver
- Out of range – move to within 30 feet of IR receiver
- EDU has been unassigned to IR receiver - refer to assignment section
- IR receiver not properly installed on EDU

Shades in a room move on their own

- EDUs are assigned to control in another room- refer to assignment section

Lutron Shading Solutions by VIMCO

7200 Suter Road

Coopersburg, PA 18036

www.lutron.com/shadingsolutions

customer service and

24/7 tech support

1-800-446-1503

fax:1-804-752-3366

email: shadinginfo@lutron.com

©01/2006 LUTRON Electronics Co., Inc.

Printed in the U.S.A.

P/N 367-592 Rev. D

