

## QSE-CI-NWK-E Control Interface

### Description

The QSE-CI-NWK-E is a versatile integration access point for Lutron’s QS-based systems. Through either RS232 or TCP/IP over Ethernet, third-party devices can control and/or monitor a QS system.

### Key Features

- Easily integrate with touchscreens, PCs, A/V systems, or other digital systems and devices.
- Control and monitor GRAFIK Eye® QS, Sivoia® QS, Energi Savr Node™, and other products on the wired QS link.
- Monitor lighting scenes, levels, and shade positions.
- Up to ten (10) QSE-CI-NWK-E control interfaces are allowed per QS link.
- The QSE-CI-NWK-E is Quantum® compatible. Refer to the *Quantum System Specification Sheet* for compatibility details.



### Requirements

- QS Link Power Supply, such as a:
  - *GRAFIK Eye QS*.
  - QS Link power supply, such as the QSPS-P1-1-50.
  - *Energi Savr Node*.
- QS Communication Link Wire (PELV, Class 2: USA)
  - Two 18 AWG (1.0 mm<sup>2</sup>) conductors for control power.
  - One twisted, shielded pair of 22 AWG (0.5 mm<sup>2</sup>) for data link.
  - Available from Lutron, part number GRX-CBL-346S; check compatibility in your area.

### Protocol

- Protocol document P/N 040-249 included on a CD accompanying the packaged QSE-CI-NWK-E.
- Also available for download at [www.lutron.com/qs](http://www.lutron.com/qs).

Job Name:	Model Numbers:
Job Number:	

### Dimensions

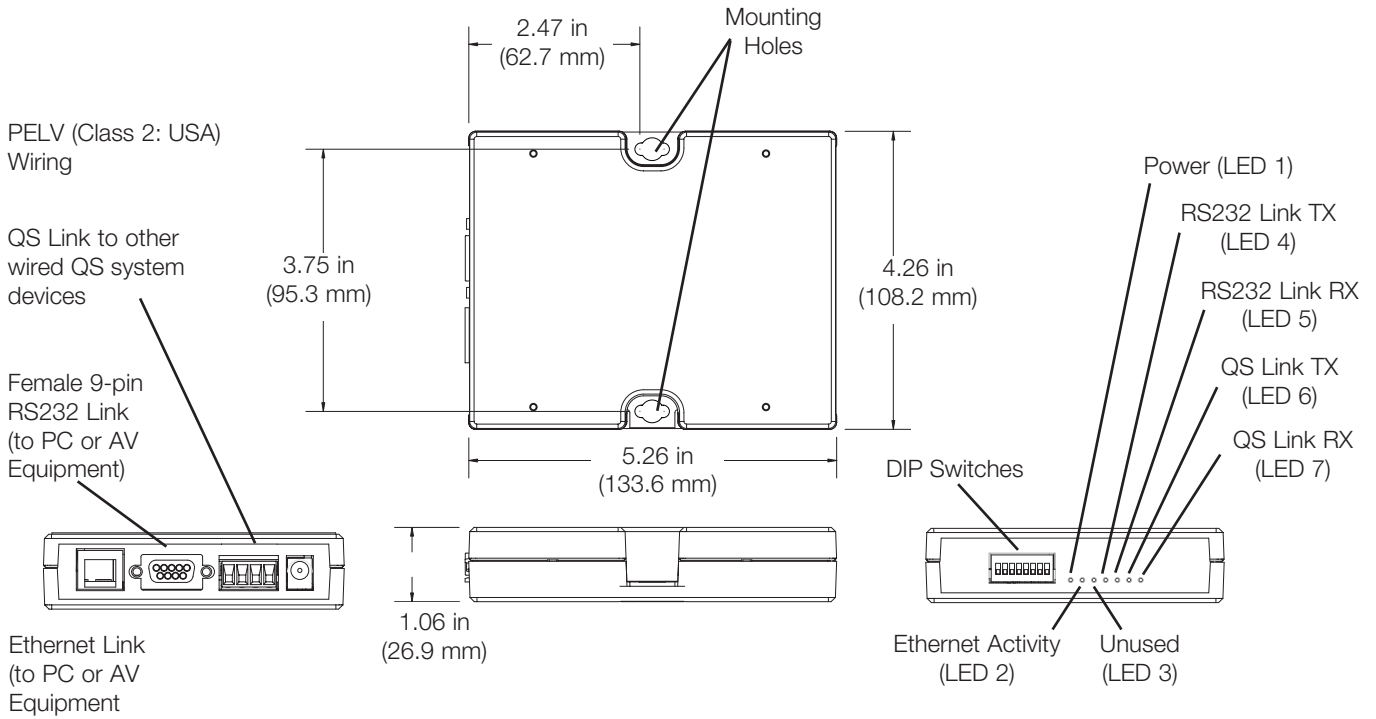

### Mounting

#### Mounting Diagram

1. Mount the control interface directly on a wall, as shown in the Mounting Diagram, using screws (not included). When mounting, provide sufficient space for connecting cables. The unit can also be placed in the LUT-19AV-1U AV rack using the screws provided with the unit. The LUT-19AV-1U will hold up to four units. If conduit is desired for wiring, the LUT-5x10-ENC can be used to mount one unit.
2. Strip 3/8 in (10 mm) of insulation from wires. Each data link terminal will accept up to two 18 AWG (1.0 mm<sup>2</sup>) wires.
3. Connect wiring as shown in the Wiring Diagram (next page). LED 1 lights continuously (Power) and LED 7 blinks rapidly (Data Link RX) when the Class 2 (PELV) Data Link is installed correctly.

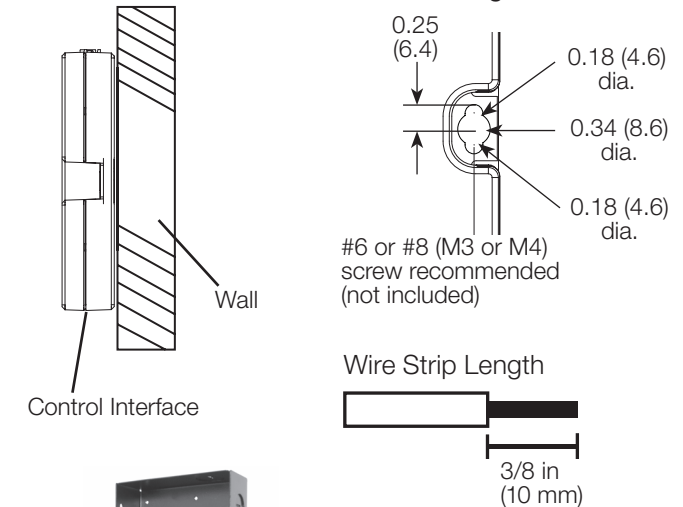

Job Name:	Model Numbers:
Job Number:	

## Specifications

### Power

- PELV (Class 2: USA).
- Operating Voltage: 24 V $\overline{=}$  60 mA.
- Uses two (2) power draw units on the QS link.

### Environment

- 32 to 104 °F (0 to 40 °C). Relative humidity less than 90% non-condensing.

### Integration Features

- Monitoring: Current scene, zone level, button presses, shade group levels.
- Control: Scene selection, scene lockout, zone lockout, sequencing, zone raise/lower, master raise/lower, set shade group level, simulate button press/release.

For the full list of features and commands, please refer to the protocol document on the accompanying CD, also available at [www.lutron.com](http://www.lutron.com).

### RS232 Connection

- Standard 9-pin female serial connector on interface. Use the included serial cable with standard 9-pin male connectors to connect to RS232 equipment.
- 50 ft (15 m) maximum serial cable length.
- Dip switches are set at factory, all Off.
- Dip switches are used to set RS232 baud rate:

#### DIP Switch Settings for RS232 Baud Rate

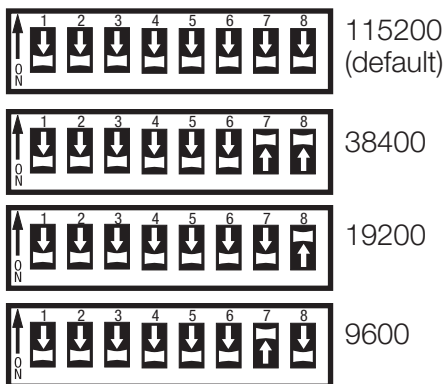

### Ethernet Connection

- Standard CAT5 (or better) cable, 328 ft (100 m) maximum, connects the QSE-CI-NWK-E interface to a PC or other Ethernet source.
- Supports MDI/MDIX auto-crossover (no crossover cable needed).
- Auto-negotiation of 10 or 100 Mbps speed and full- or half-duplex operation.
- Default IP address is 192.168.250.1. Can be changed using the Lutron DeviceIP tool located on the accompanying CD.

**Note:** Either the RS232 or the Ethernet can be used, but not both.

Job Name:	Model Numbers:
Job Number:	

## RS232 Link Wiring

- 9-pin to 9-pin serial cable provided.
- Standard 9-pin serial connector plugs into RS232 equipment, and to QSE-CI-NWK-E.
- Must be 50 ft (15 m) or less.

### RS232 Signals

Signals	Pin on 9-pin Cable
Com	5
TxD	3
RxD	2

## Ethernet Link Wiring

- Standard CAT5 cable connects QSE-CI-NWK-E Interface to PC, router, or other Ethernet source.
- No crossover cable needed.
- Must be 328 ft (100 m) or less.
- Ethernet network and cable provided by others.

## Control Interface Wiring

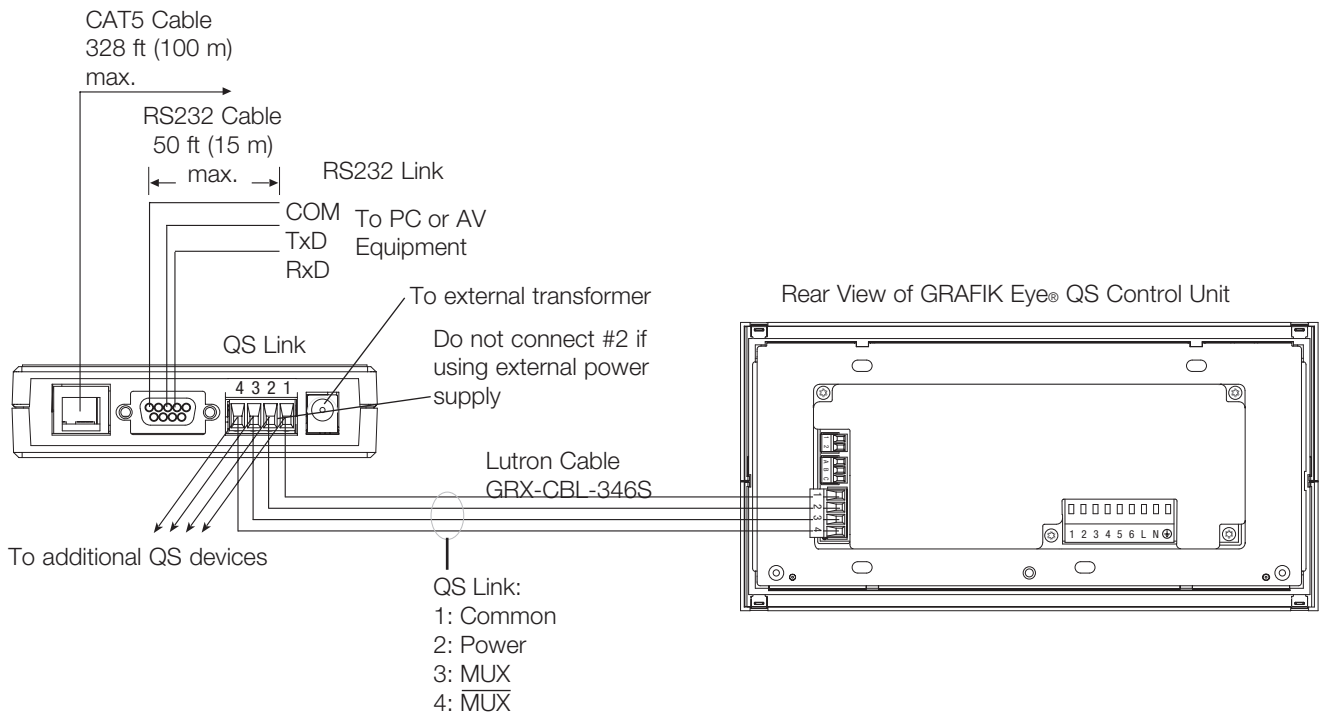

<b>Job Name:</b>	<b>Model Numbers:</b>
<b>Job Number:</b>	

## PELV (Class 2: USA) QS Link Requirements and Wiring

- System communication uses PELV (Class 2: USA) wiring.
- Wiring can be daisy-chained or T-tapped (see below).
- Wiring must be run separately from line/mains voltage.
- Each PELV (Class 2: USA) terminal accepts up to two 18 AWG (1.0 mm<sup>2</sup>) wires.
- PELV (Class 2: USA) wiring link requires:
  - Two 18 AWG (1.0 mm<sup>2</sup>) conductors for control power.
  - One twisted, shielded pair of 22 AWG (0.5 mm<sup>2</sup>) for data link.
  - Available from Lutron, P/N GRX-CBL-346S; check compatibility in your area.
- Total length of control link must not exceed 2000 ft (610 m).
- Connect the terminal 1, 3, and 4 connections to all control units, wallstations, and control interfaces. See Powering the QSE-CI-NWK-E for pin 2 connectivity.

### Daisy-Chain Wiring Example

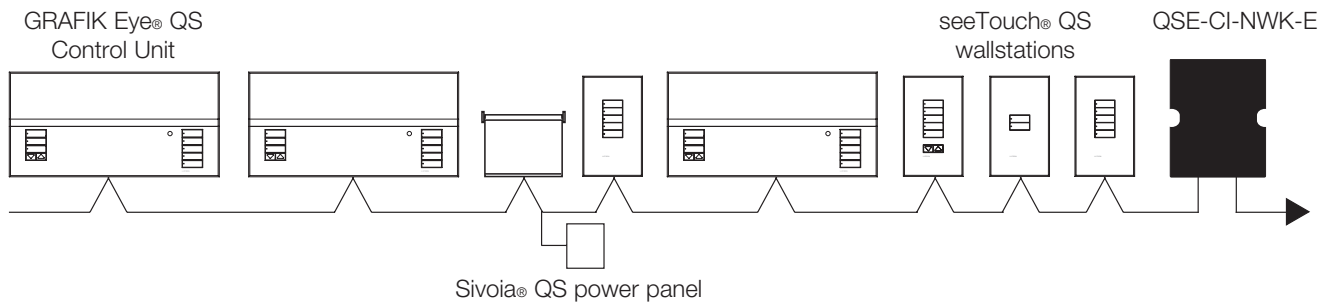

### T-Tap Wiring Example

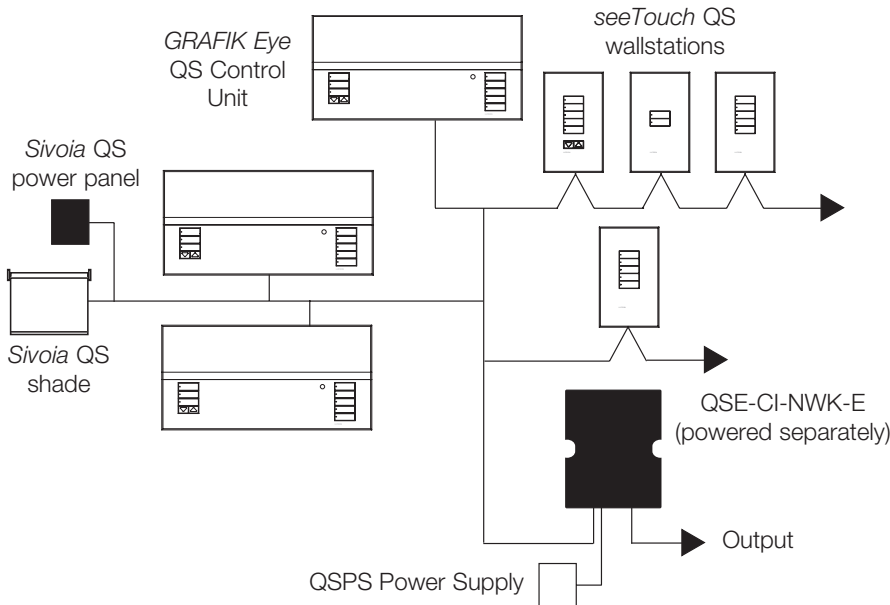

Job Name:	Model Numbers:
Job Number:	

## PELV (Class 2: USA) Terminal Connections

### When used with GRAFIK Eye® QS Control Units

- Two 18 AWG (1.0 mm<sup>2</sup>) conductors for Common (terminal 1) and 24 V<sub>DC</sub> (terminal 2). Ensure that the terminal 2 connection is wired correctly. Refer to *GRAFIK Eye QS Specification Submittal* for more details.
- One shielded, twisted pair 22 AWG (0.5 mm<sup>2</sup>) for data link (terminals 3 and 4).

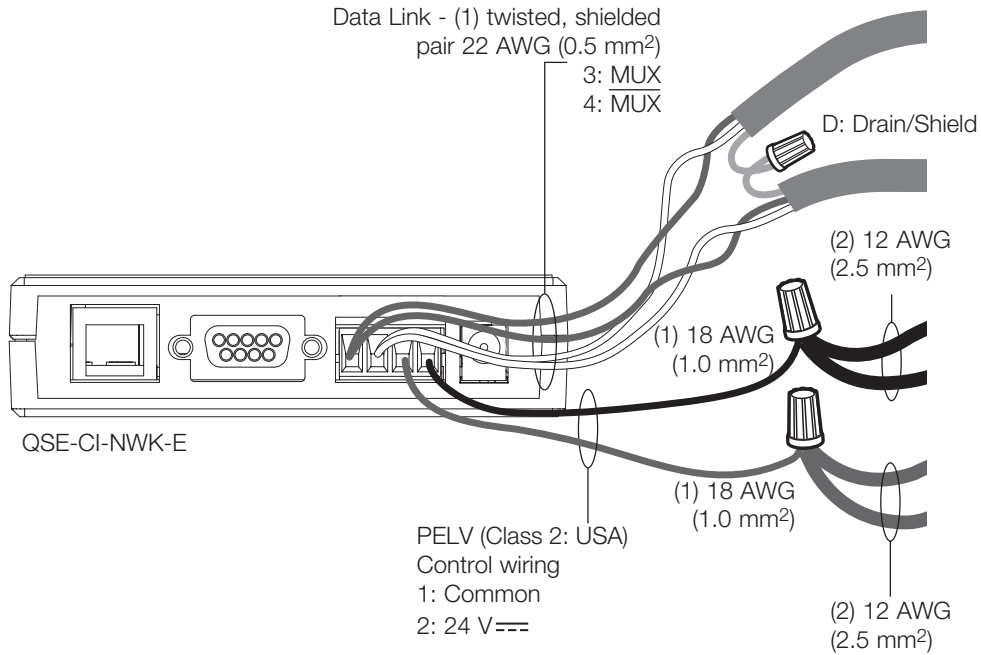

Job Name:	Model Numbers:
Job Number:	

