

Calibrating Low End of a Fluorescent Dimming Control

Method One: Using a Multi-Meter (Lutron recommends this method for the most accurate results)

Note: It is very important that a true RMS meter be used when doing low end calibration. Lutron recommends the use of a high quality multi-meter (as an example a Fluke 8060A meter) to guarantee accuracy.

1. Install ballast(s) and control as indicated on the appropriate wiring diagram.
2. Measure switched hot to neutral voltage and record this value as you will need it in Step 4. This value is your incoming RMS line voltage.
3. Put multi-meter wires on the dimmed hot and neutral wires and measure the voltage. This will be your low end RMS voltage.
4. If this is not sufficient, rotate the trim adjustment on the unit such that your low end RMS voltage is equal to 0.47 times the incoming RMS voltage that you measured in Step 2.
5. If using a microWATT, PerSONNA or Ballast Control Interface, then rotate trim on unit until the meter reads 0.65X the incoming line voltage.
6. Your unit is now properly calibrated. For additional details please consult the instruction manual or contact the Lutron Hotline (1-800-523-9466 USA, Canada, the Caribbean).

Method Two: Using a Light Meter

Before low-end calibration can be performed, the fluorescent lamps must be run at full intensity for 100 hours. If this burn-in procedure is NOT performed, an accurate footcandle measurement will not be achievable. When using a light meter, it is important to place the meter at distance of five to seven feet directly below a fixture. Also, while performing the calibration, the meter must remain in a stationary position; DO NOT hold the meter in your hand, but instead use a flat surface, i.e. a table.

IMPORTANT: Lutron recommends the use of a high quality digital light meter (for example, a Minolta T1 Illuminance Meter) to guarantee accuracy.

1. After performing the 100 hour burn-in, turn the power off at the dimmer and measure the ambient light in the room.
2. Turn the dimmer back on and run the lamps at full intensity for 15 minutes. This ensures an accurate high-end measurement by allowing the lamps to sufficiently heat-up.
3. Subtract the ambient light level from the reading currently on the light meter. This is the lamp's measured footcandle level at high-end.
4. Set the dimmer to the minimum position and let the lamps run at low intensity for 15 minutes. This ensures an accurate low-end measurement by allowing the lamps to sufficiently cool down.
5. Subtract the ambient light level from the reading currently on the light meter. This is the lamp's measured footcandle level at low-end.

IMPORTANT: THE AMBIENT LIGHT LEVEL MUST BE A VALUE THAT IS NO GREATER THAN 10% OF THE MEASURED LOW-END, i.e. if the low end measures 10 footcandles, than the ambient light level cannot exceed one footcandle.

6. If the ambient light level is *GREATER* than 10% of the low-end value, than an accurate measurement will not be achievable. The ambient light level must be reduced and Steps 2 through 5 need to be repeated. If this is not the case, than proceed to Step 7.
7. While the lamps remain at low intensity, the low end trim on the dimmer can be adjusted to meet 1%, 5%, or 10% dimming, depending on the model of Lutron ballast that is currently installed.

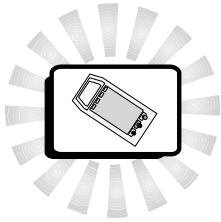

Function Testing Ballasts and Controls

Dimming Fixture Installation Testing A Test Circuit Must Be Made:

Connect the fixture to be tested to the control output terminals. Connect a bypass jumper between the switch hot and control terminals. Turn on the Lutron fluorescent dimming control, the lamps should go to full brightness. If the lamps do not switch on then check the ballast wiring.

Switch off the power and remove the switched hot to control bypass jumper.

Re-apply power to the circuit.

Turn on the Lutron fluorescent dimming control, check that the lamp(s) strike when the control is turned on, at the minimum dimming position, also check that turn on can be achieved when control is turned on at the maximum dimming position. Once satisfactory starting has been confirmed - check that the lights dim smoothly and flicker free by continuously adjusting the dimming control between minimum and maximum levels.

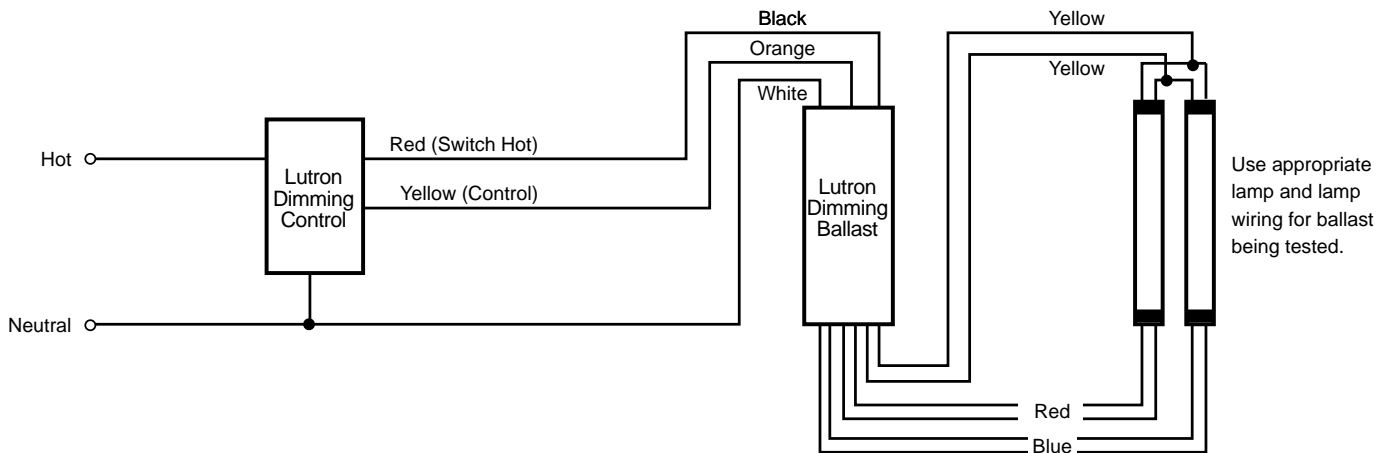

Wiring Eco-10 Ballasts with 1 5/8" T8 U-Bent Lamps

Eco-10 (ECO-Series) ballasts with 1 5/8" T8 U-bent lamps

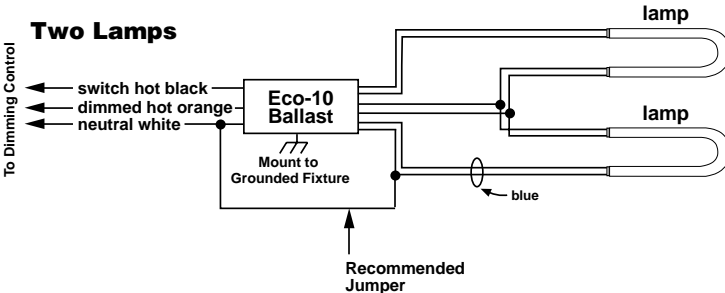
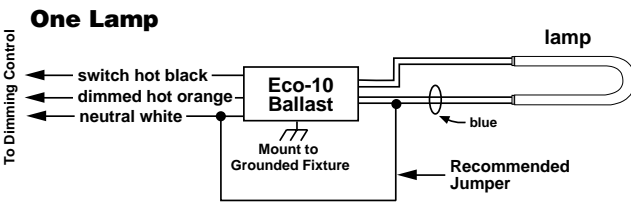

Wiring of one- and two-lamp Eco-10 (ECO-Series) ballasts should be modified to aid striking when the ballasts are used with 31W 1 5/8" U-bent lamps only. A jumper wire should be connected from either blue wire to neutral. Jumper does not affect UL listing. Jumper is not required for three-lamp ballasts.

The blue wire to neutral jumper applies only to the following four ballast models:

- ECO-T832-120-1
- ECO-T832-120-2
- ECO-T832-277-1
- ECO-T832-277-2

Jumper connections should not be made on any ballast model other than those listed.

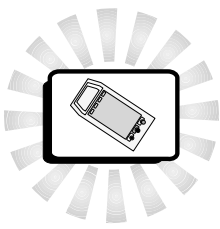

Test the Wiring While in Bypass

Turn the input power ON after assuring that it is safe to do so.



Danger - Check that all loads on the circuit are safe to have power applied before turning the input power ON.

Lights should come ON to full. If there is a switch to turn the load ON and OFF, confirm that it works correctly.

Once the wiring is tested, turn the input power back to the OFF position.



Danger - Locate and lock the supply breaker in the OFF position, or remove the supply fuse before continuing.

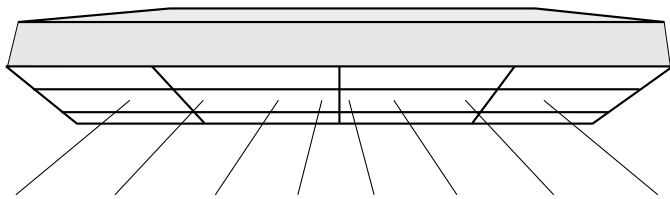

Lights should go to Full ON while in bypass.

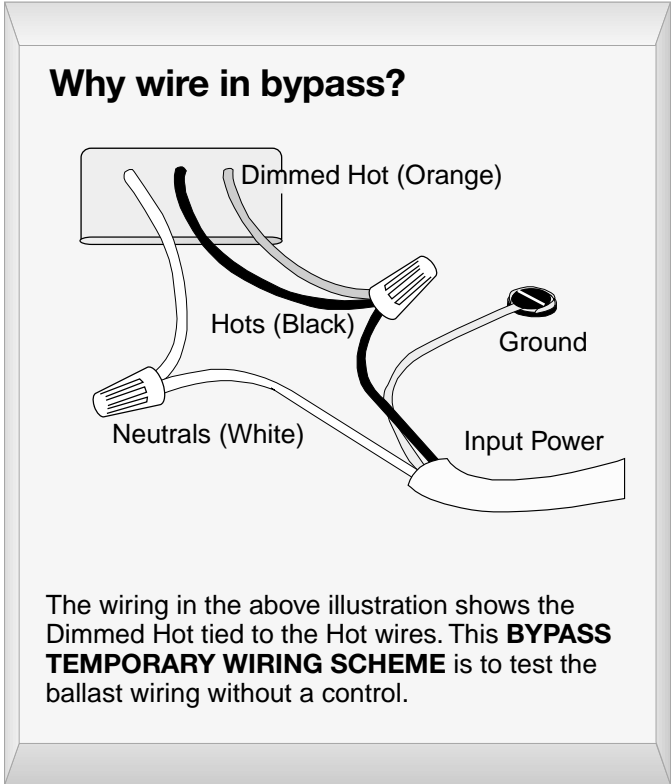

Testing for Mis-Wires

Input Wires (Black, White, Orange)

These wires provide power and control signal to the ballast.

An incandescent light bulb of the appropriate voltage or a volt meter can be used to determine if power and signal are getting to the ballast.

1. Connect the light bulb from black to white at a ballast. Turn the control dimmer on and off - the bulb must come on and go off; the bulb must not dim. If it does dim then switched hot and dimmed hot are reversed somewhere between the dimmer and the ballast.
2. Connect the light bulb from orange to white at a ballast. The bulb must dim smoothly with the control. It must go off when the slider is pushed to off or the off scene selected. If the bulb does not do this there is either a mis-wire or the dimmer is shorted. If the system is working properly, the bulb will dim smoothly to 1/2 its full intensity.

Output Filament Wires (Red, Blue, Yellow)

1. With the power off, remove the lamps from a fixture. Using an ohm meter (DMM) measure the resistance between the two pin connections in each lamp holder. Each lamp holder should read between 0 and 2 ohms. If any lamp holder measures open - then wires are not properly connected.
2. Using the ohm meter set a 1K ohm or less scale, measure from one lamp holder to the opposite lamp holder for each lamp. All connections must read an "open circuit". Any shorts indicate a mis-wire.

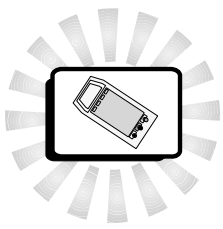

Fixture Voltage Map

When testing for mis-wires follow this procedure.

Where to Measure	Voltage (use a True RMS Voltmeter)	
	Without lamp	With lamp
Control (Orange) to Neutral (White)	Low End – see note 1 High End – see note 2	
Hot (Black) to Neutral	Line Voltage $\pm 10\%$	
Blue to Blue	4V to 8V	3V to 5V
Red to Red	4V to 8V	3V to 5V
Yellow to Yellow	4V to 8V	3V to 5V
Blue w/WH to Blue w/WH	4V to 8V	3V to 5V

Notes:

1-See calibrations with multi-meter (page 18)

2-In bypass mode/dimmer at full intensity



Danger - Readings must be done while the circuit is energized. Apply the voltage only to the meter.



Danger - Do not measure from one colored lamp wire to another colored lamp wire (such as from Red to Blue). This could exceed the voltage rating of your meter.

