

Centralized Lighting Control Systems

A centralized lighting control system provides switching, dimming, energy management, and shade control from a single system. It is used to manage the lighting in multiple spaces and for various needs and includes both manual and automatic control options.

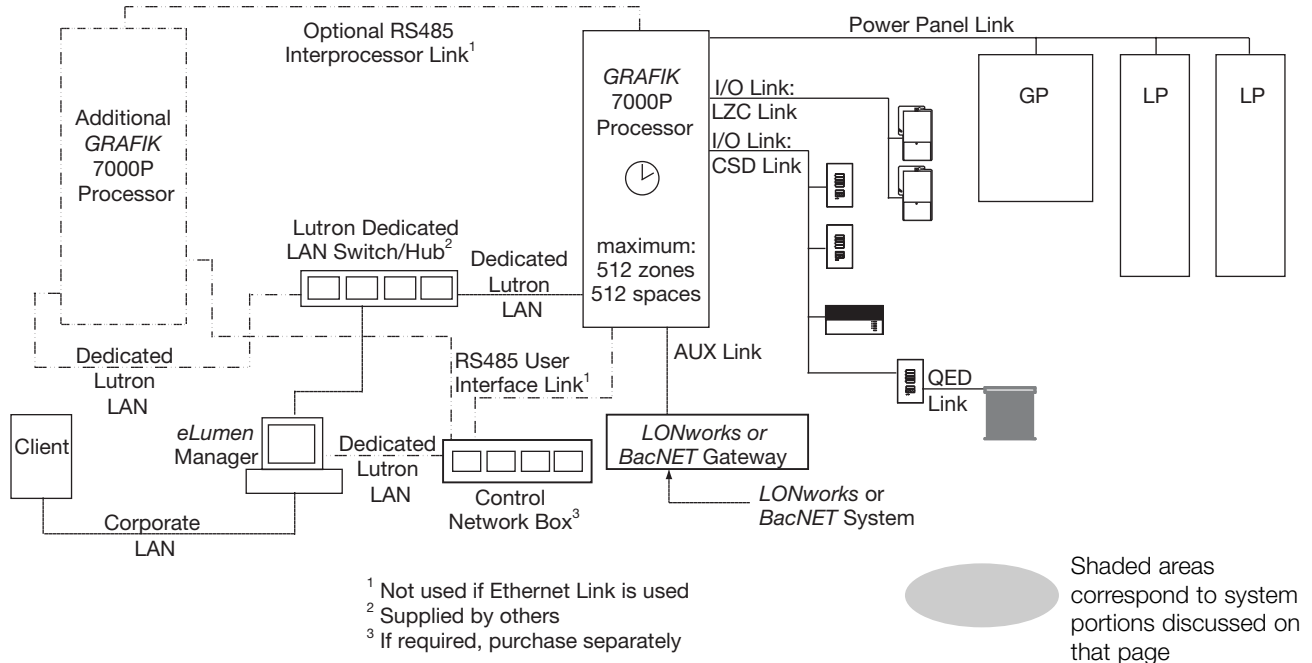

Features

- Designed to manage and control all lighting (dimmed and switched) in a building
- Easily interfaces with audio-visual equipment, stage equipment, security systems, fire alarms, and building management systems
- Built-in astronomic time clock allows scheduling of events; one-time events may be scheduled up to one year in advance
- Run a pre-programmed automatic sequence of lighting events at the press of a button or via a time clock trigger; cannot be started from a Video or a handheld Programmer (HHP)
- Partitioned space control combines/separates lighting scene control to reflect the partition status of movable walls
- Programming of each button can be based on conditional logic (IF-THEN-ELSE commands elicit different functions for the button)
- Controls can be programmed on a button-by-button basis
- Designed to include Lighting Zone Controllers (LZC), which are also used in the *Digital microWATT™* system. Specific details on Lighting Zone Controllers operation can be found in the section labeled Lighting Zone Controllers
- Groups and modes can be used to group and affect objects, which can simplify programming of complex spaces

Job Name:	Model Numbers:
Job Number:	

- Optional *eLumen*™ Managers include *Windows*®-based *DesignIT*™ for system design and setup
- Optional *ControlIT*™ and *PictureIT*™ software allow real-time system control
- Optional *SecureIT*™ software allows the building's system administrator to create and assign usernames and passwords
- Optional *ScheduleIT*™ software allows temporary timeclock event scheduling changes
- Optional *ConfigureIT*™ software allows easy real-time scene programming
- Multilingual software capabilities: English (US), German, Spanish, French, Chinese (simplified), Japanese

System Capabilities

- Up to 32 processors per system

Processor Capabilities

- 512 zones
- 512 spaces
- 1 power panel link (RS-485)
- 6 I/O links (RS-485)
- 1 10/100-Base-T Ethernet link (auto detecting)
- 1 interprocessor link (RS-485)
- 1 AUX link (RS-485 or RS232) used for BMS integration

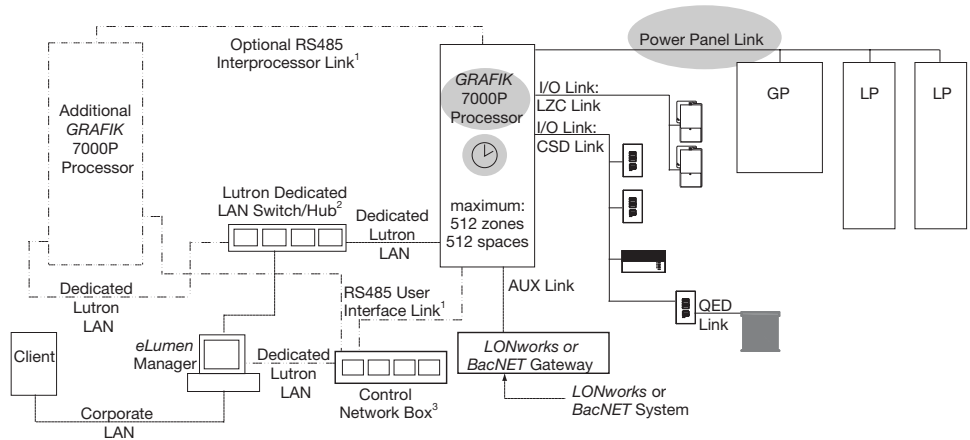

¹ Not used if Ethernet Link is used
² Supplied by others
³ If required, purchase separately

Time clock

- 1 project time clock, and 1 time clock per space
- Each time clock can contain daily schedules and exception schedules
 - Daily schedules repeat every day of the week (i.e., a Monday schedule, Tuesday schedule, etc.)
 - Exception schedules occur on a specific date
 - Multiple schedules (daily and exception) can be combined on the same day
- Up to 32 different schedules or scheduled events per time clock
- Astronomic events can be set up to 2 hours before or after sunrise or sunset
- Viseo, wallstations, and other input devices (via RS-232 integration) can enable and disable space time clocks
- Daylight saving time can be defined according to any system used anywhere in the world

Power Panel Link

- 1 power panel link per processor
- 125 power panels (circuit selectors) on the link (up to 4500 circuits)
- Power panel link connects the processor to the power panels, including: GP, LP, XP, CCP, JDP, JCP, DCI, DP, and DMX512 outputs via a LUT-DMX

Job Name:	Model Numbers:
Job Number:	

10/100 Base-T (autodetecting)

**Ethernet Link
(dedicated Lutron LAN)**

- Uses Ethernet for processor programming from *eLumen* Manager and for interprocessor communication
- Requires a dedicated (Lutron only) Ethernet network or subnet
- Network must support multicast protocol for interprocessor communication

Interprocessor Link (RS-485)

- Allows interprocessor communication via RS-485
- Not required if using Ethernet link for interprocessor communication

AUX Link

The AUX link is used for building management system integration via a gateway

- 1 *BACnet* or *LonWorks* gateway per processor; multiple gateways on a single processor are not supported
 - Gateway must be located within 2000 feet of the processor; AUX link signal cannot be boosted
- Gateway provides control of all of the scenes in up to 500 spaces on the local processor
 - Scenes can affect all power panel lighting zones, Lighting Zone Controller zones, and control station output devices, including shade integration control and contact closure outputs
- As an alternative to scene-based control, a gateway can provide direct control to 512 lighting zone intensities through the power panel link (In zone-control, scene-based control is not available.)
 - Gateway can only directly control zones on processors that are connected to the gateway. Zone control on other processors is not available through the AUX link.
 - Lighting Zone Controllers, OMX-3600, OMX-4600, SO-SVC interfaces and CCOs cannot be controlled by zone control

Note: For *BACnet* and *LonWorks* integration of systems with multiple processors, one gateway is needed for each processor.

User Interface Link

- Allows local programming of processor via RS-485
- Not required if using Ethernet link for interprocessor communication

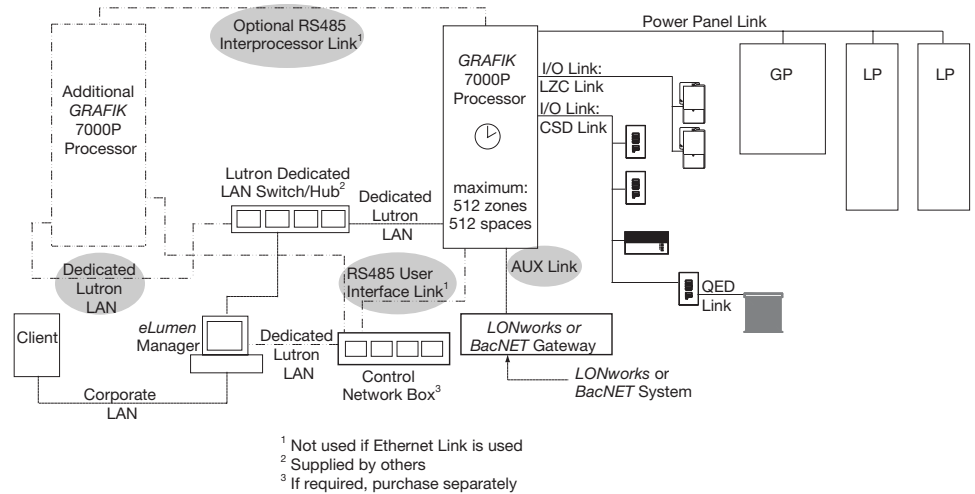

Job Name:	Model Numbers:
Job Number:	

Configurable Links

- 6 configurable links per processor
 - Each link can be independently configured as a Control Station Device (CSD) or Lighting Zone Controller (LZC) link
 - Up to 32 CSDs per link (total of 192 devices per processor)
 - Up to 63 LZCs per link (total of 378 devices per processor)
- CSD and LZC devices cannot be connected to the same link

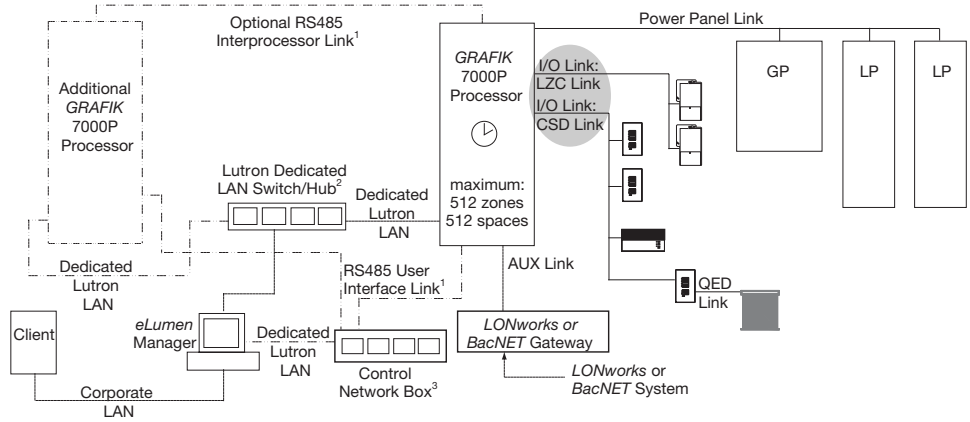

¹ Not used if Ethernet Link is used
² Supplied by others
³ If required, purchase separately

Control Station Device Functions

Device	Controls dimmers or relays in power panels connected to the same processor panel	Controls zones other than Power Panel Zones (shades, LZCs, etc.)	Controls zones on any processor in the system
Wallstations			
seeTouch	✓	✓	✓
Single-button	✓	✓	✓
Architectural	✓	✓	✓
European	✓	✓	✓
Slim-button	✓	✓	✓
Large-button	✓	✓	✓
Architrave	✓	✓	✓
GRAFIK Eye Preset Controls			
3600 Series	✓	✓*	✓*
4600 Series	✓	✓	✓
Ceiling-mounted infrared receiver	✓	✓	✓
OMX-DACPI daylighting control	✓	✓	✓
OMX-RACP partition status assigner	✓	✓	✓
Control Interfaces			
OMX-AV contact closure I/O	✓	✓	✓
CCO-8 relay closure output			
OMX-WCI contact closure inputs	✓	✓	✓
OMX-RS232 RS-232 interface	✓	✓	✓
OMX-CI-RS232 RS-232 interface	✓	✓	✓
OMX-NWK-E interface	✓	✓	✓
SO-SVC Sivoia QED output			
ODMX-512 DMX-512 input	✓	✓	✓
Visco	✓	✓*	
HHP handheld programmer	✓	✓*	
Slider Controls	✓		

*Scene control only

Note: Lighting zone controllers are remote mounted localized dimmers and do not act on other components in the system. LZCs can only receive control signals; they cannot control other devices. Functionality is covered in the Lighting Zone Controllers section.

Job Name:	Model Numbers:
Job Number:	

Control Station Device

Programming

- Conditional logic
 - Allows nested or sequential IF-THEN-ELSE commands up to 32 levels
 - Allows wallstation and control inputs to execute customized programming scripts
 - Affects any of the spaces or zones on the processor to which the control input device or wallstation is wired
- LED logic
 - Scene, room (given a collection of non-Lighting Zone Controller zones, only one zone needs to be on to illuminate the LED), last scene, pathway (given a collection of non-Lighting Zone Controller zones, all zones must be on to illuminate the LED), and inverse of these
- Button-by-button programming
 - Allows any button to control any hardware in the system (space, zone, time clock, group, or auto sequence)
 - Dual action programming of a button cannot activate auto sequences or conditional logic events
- Partitioning
 - Up to 32 sub-spaces per space
 - Partition spaces must be contained to one processor
 - Viseo can not control or display partitioned spaces
 - Sliders can not control across partitioned spaces

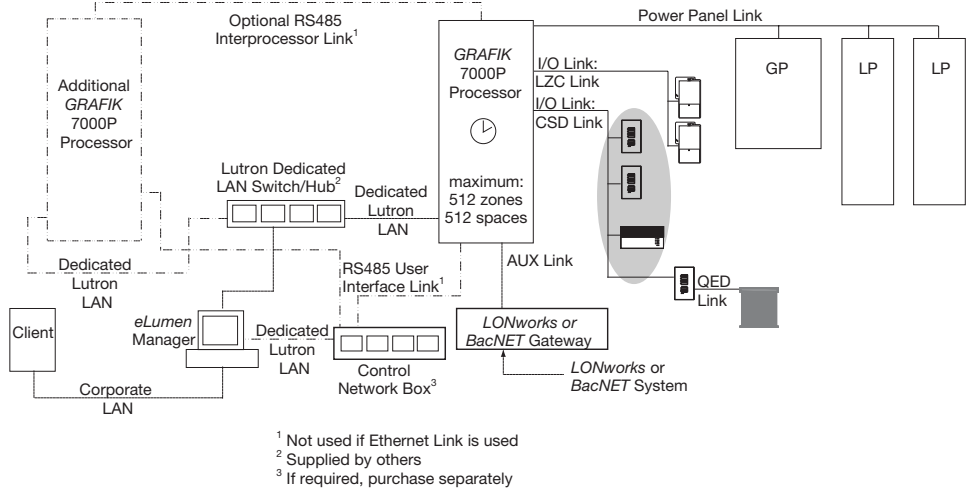

Job Name:	Model Numbers:
Job Number:	

Lighting Zone Controllers

The *DesignIT eLumen* software will provide the following functions and capabilities (must be run from *eLumen Manager*):

- Adjusting high-end trim
- Adjusting low-end trim
- Adjusting unoccupied light level
- 100-hour burn-in activate and override
- Enable/disable daylight sensors, occupant sensors, and/or wall controls
- Activate/deactivate load shed condition

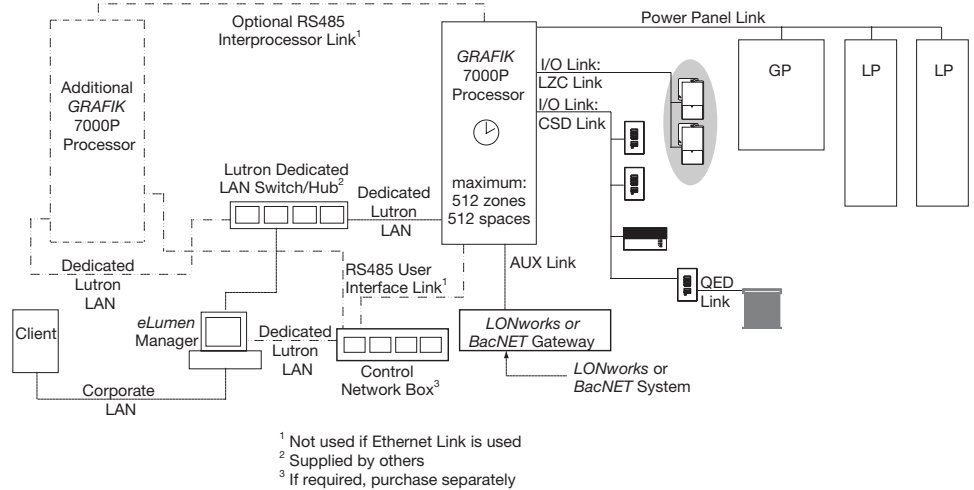

The *ControllIT eLumen* software will *adjust and monitor* **OR** *monitor only* the following parameters for individual or groups of Lighting Zone Controllers:

Adjust and Monitor

- Low-end and high-end setting
- Daylight sensor gain
- Occupant sensor time-out extension
- Unoccupied light level
- Load shed condition
- Emergency status
- Enable/disable wall controls, daylight sensors, and occupant sensors
- User-set light level

Monitor Only

- Actual light level
- Occupancy status
- Daylight sensor cutback
- Current or past power usage
- Timeclock schedule

Job Name:	Model Numbers:
Job Number:	

**Lighting Zone Controllers:
Reporting**

- Light Level report
 - Span is user-definable by a start and end date/time
 - Resolution is user-definable from one minute to one month
- Shows:
 - Actual light level
 - Daylight sensor level
 - Load shed (% reduction)
 - Occupied status (true or false)

- Power report
 - Span is user-definable by a start and end date/time
 - Resolution is user-definable from one minute to one month
- Shows:
 - Average power (Watts)
 - Summary of energy used over report period (Watt-hours)
- Missing In Action (MIA) Report
 - Shows:
 - Total Lighting Zone Controller units
 - Number of units MIA
 - Name of unit
 - Date/time entered into MIA

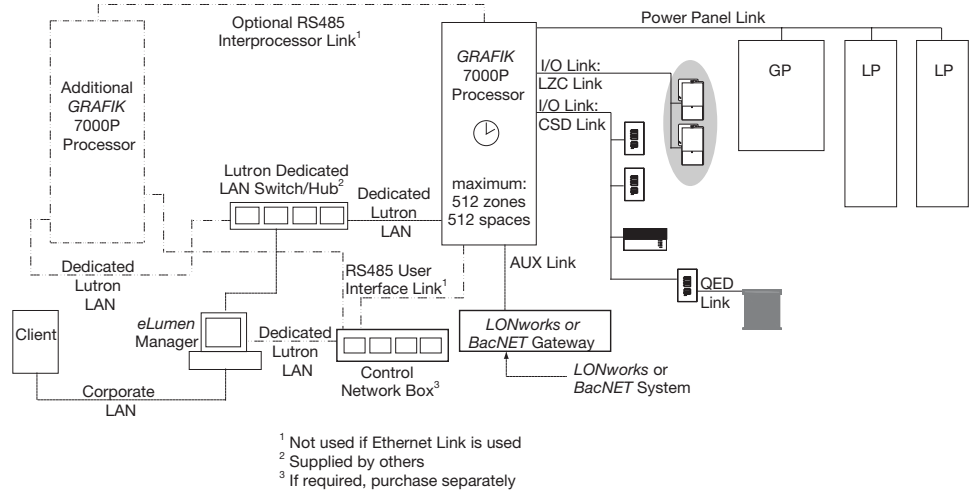

Job Name:	Model Numbers:
Job Number:	

eLumen Managers

Servers

Dedicated computers that are used to support system operations 24 hours per day. Servers may have redundant power supplies and multiple hard drives (Redundant Array of Inexpensive Disks, or RAID) for reliable 24-hour operation, and come with *eLumen* software installed.

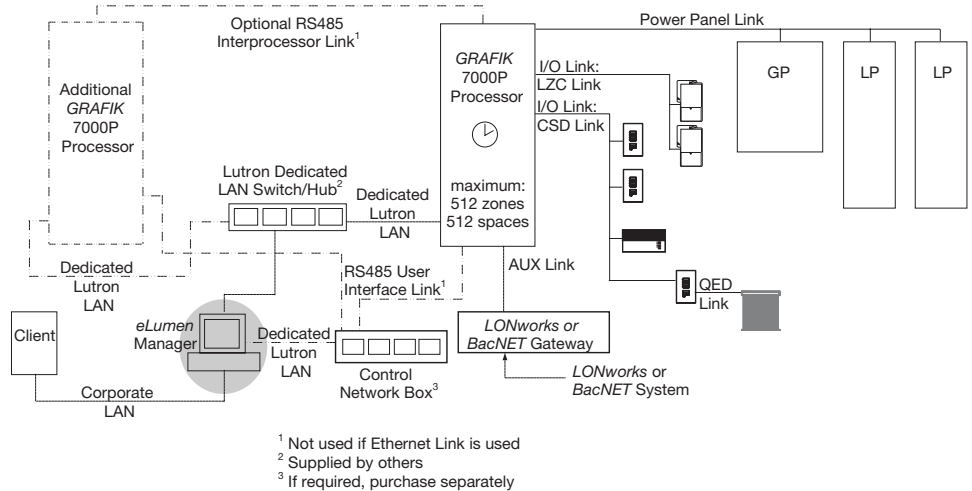

¹ Not used if Ethernet Link is used
² Supplied by others
³ If required, purchase separately

- Available only with GRAFIK 7000 system
- Servers are required for data recording and reporting functionality, *ScheduleIT* operation, and systems that use a custom graphical user interface for system monitoring and control
- Servers are required if the system is connected to more than one computer (client)
- Servers are required for Lighting Zone Controller systems
- Servers are available with standard or RAID drives
- Servers may be ordered with an optional North American telephone interface designed for use with PSTN systems that requires an analog PSTN line to function properly (the telephone interface is not designed for use with PBX systems)
- Operation of the telephone interface allows voice-prompted touch-tone operation using the following commands:
 - Adjust a zone level
 - Select a scene
 - Select a group/mode combination
- Servers are dedicated for use with the Lutron Lighting Control System only

Personal Computers

Computers that are provided by Lutron with *eLumen* software used to set up and make changes to the lighting control system. Personal computers are intended for occasional use only

- Personal computers are available as laptop or desktop models
- Personal computers are dedicated for use with the Lutron Lighting Control System only

Note: For system modifications, an *eLumen* Manager, HHP or *Viseo* is required. Each will provide different levels of functionality.

Job Name:	Model Numbers:
Job Number:	

Software

The software packages listed below reside within the *eLumen* Manager.

DesignIT

Creates the database that defines, modifies, and updates the centralized lighting control system.

- Set up lighting schemes using a *eLumen* Manager running *Windows 2003* or *Windows XP* Pro; the user will be able to:
 - Select and define areas within a desired space
 - Designate control stations within spaces
 - Name zones within spaces
 - Assign switch legs to zones
 - Create groups
 - Groups contain one or more controllable objects (zones, spaces, control stations, time clocks, or variables) in any combination
 - Controllable objects may be included in one or more groups
 - Create modes
 - Modes may be applied to any group in the system
 - Modes contain preset values for every controllable object (unaffected, user controlled, locally controlled, and automatically controlled)
 - Program control station devices
 - Add panels to spaces
 - Create partitionable spaces
 - Scene chaining
 - Conditionals
 - Create time-clock schedules
 - Single or periodic event
 - Blink warn
 - Flash the power panel lighting zones prior to turning off due to timeclock or occupancy signals
 - Set up daylight saving time
 - Set project location (for astronomic events) and time zone
 - Create scenes
- Use the integrated partitionable space wizard for easy setup of partitionable spaces
- Compile the project and check for warnings or errors
- Connect via Local Area Network (LAN) to a project residing on an *eLumen* Manager for remote design and modification

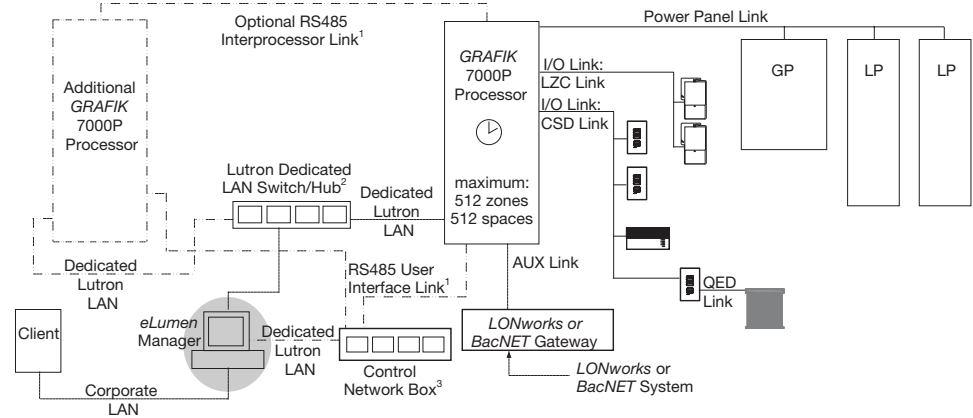

¹ Not used if Ethernet Link is used
² Supplied by others
³ If required, purchase separately

Job Name:	Model Numbers:
Job Number:	

ControlIT

Provides real-time operation (control and feedback) of the lighting control system.

- Web-browser based software can connect via LAN to a project residing on a remote *eLumen Manager*
- Provides the ability to control and monitor the lighting control system:
 - Zones
 - Set desired intensity
 - Monitor current intensity
 - Areas/spaces
 - Enable/disable time clock
 - Monitor timeclocks/events to be run
 - Select scenes
 - Set or monitor partitions/variables
 - Groups
 - Apply modes
 - Control station devices
 - Enable/disable
 - Monitor current state
 - Simulate button presses
 - Diagnostics of system hardware
- Reports
 - User activity report: view actions taken by authorized users of one of the system computers
 - Scene selection report: view current scene details
 - Scene zone intensity report: view current zone intensity, fade time, and delay time for all of the zones in the selected space
 - Light level report: view intensity of the selected zones over a period of time
 - LZC specific reports: see section entitled Lighting Zone Controllers Reporting
- Compile the project, check for warnings or errors, and transfer it from the *eLumen Manager* to the centralized lighting control system

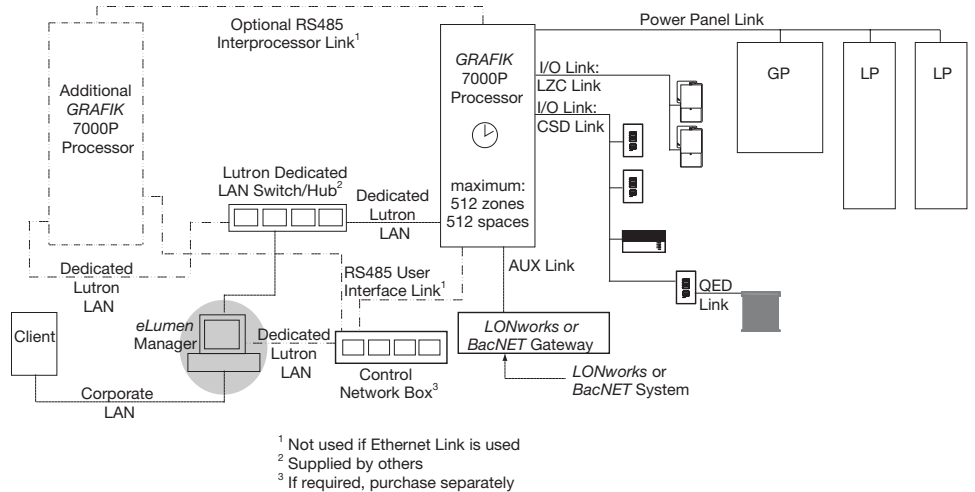

Job Name:	Model Numbers:
Job Number:	

ScheduleIT

Temporarily adjust the timing of existing timeclock events for special events without affecting the existing lighting control system schedules.

- *eLumen* Manager overrides the processor schedule and runs the special time clock events
- *eLumen* Manager must be running and connected to the processor 5 minutes before the special event is to run
- Requires a Server *eLumen* Manager

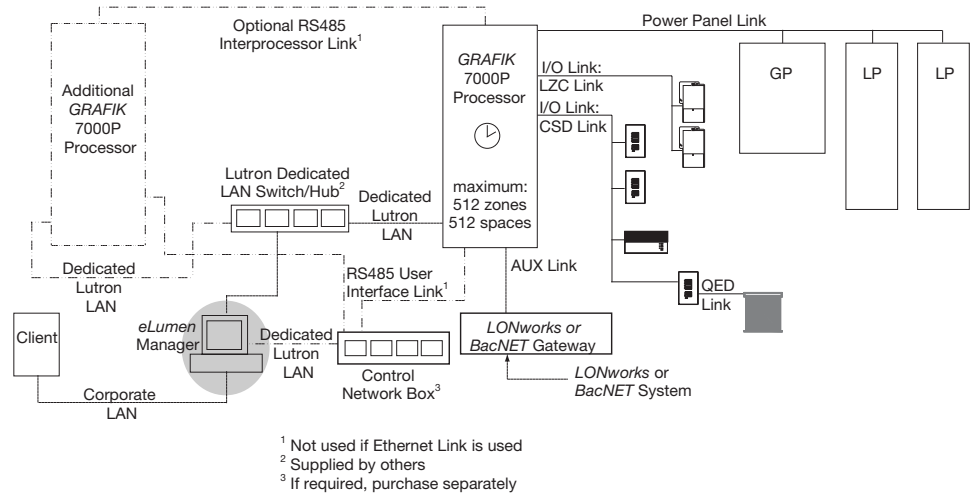

ConfigureIT

Allows real-time temporary or permanent scene programming. Power panel lighting zones are displayed as sliders in the scene to be programmed. Programming is via adjusting slides and pressing the program button.

SecureIT

Allows the building's system administrator to assign users specific usernames and passwords. This then allows the user to run any of the *eLumen* software components.

- The software also allows the administrator to select the preferred language of the users from the following list: English (US), German, Spanish, French, Chinese (simplified), Japanese

PictureIT

Provides a visual tool that allows the user to control and receive real-time feedback from the lighting control system through intuitive and interactive custom graphics. This software is included with the purchase of the Lutron Graphical User Interface (GUI) design service.

- Graphical software allows easy, picture-based navigation through logical screens, from the global plan to specific areas, and allows the user to monitor and control the lighting system in real time, including:
 - Zones
 - Set desired intensity
 - Monitor current intensity
 - Areas/spaces
 - Enable/disable time clock
 - Select scenes
 - Set or monitor partitions/variables
 - Control station devices
 - Enable/disable
 - Monitor current state
 - Simulate button presses
- Requires an *eLumen* Manager

Job Name:	Model Numbers:
Job Number:	

Graphical User Interface (GUI) Design Service

- *PictureIT* (see above) is included with the GUI design service.
- Web-based graphical software can display an overview of the building areas, beginning with the entire facility and proceeding to successively more detailed views of individual areas
- Level 3 graphics provides the following information per page:
 - 8 control buttons
 - 8 navigation points
 - 8 monitoring points
- Level 2 graphics provides the following information per page:
 - 8 control buttons
 - 8 navigation points
- Level 1 graphics provides the following information per page:
 - 8 control buttons
- Additional pages can be purchased; each page provides the same features as the original level
- Graphical software is accessed via a Web server (*eLumen Manager*) provided by Lutron, and can be accessed by any personal computer that is connected to the same network as the server and running Internet Explorer 6.0 or later
- The server can be accessed via LAN (Local Area Network) and incorporates 10/100Base-T Ethernet capability supporting TCP/IP communication protocol
- The software is based on floor-plan graphics, which the customer must provide to Lutron

Job Name:	Model Numbers:
Job Number:	

Additional Notes

Viseo

- Used for local operation and programming of lighting values on a single processor
- Viseo cannot communicate to more than one processor
- Viseo does not support hierarchical spaces; it displays all spaces as a single list. For example, a hierarchical space designated Floor 1 may have East, West, North, and South sub-spaces. When viewing Floor 1, the Viseo will not display any zones programmed into sub-spaces East, West, North, or South. To view these zones, the user must select one of those sub-spaces.
- Viseo can not control or display partitioned or hidden spaces
- If Lighting Zone Controller zones are programmed into a scene, they can be operated by scene control from the Viseo; Viseo can not display Lighting Zone Controller data
- Viseo can only support ASCII 7-bit characters (26 capital and lowercase letters ‘A’ to ‘Z’, and 10 numbers ‘0’ to ‘9’)

Handheld Programmings (HHP)

- Handheld programmings (HHP) do not support hierarchical spaces; they display all spaces as a single list. For example, a hierarchical space designated Floor 1 may have East, West, North, and South sub-spaces. When viewing Floor 1, the HHP will not display any zones programmed into sub-spaces East, West, North, or South. To view these zones, the user must select one of those sub-spaces
- If Lighting Zone Controller zones are programmed into a scene, they can be operated by scene control from the HHP; handheld programmings can not display Lighting Zone Controller data
- Handheld programmings can only support ASCII 7-bit characters (26 capital and lowercase letters ‘A’ to ‘Z’, and 10 numbers ‘0’ to ‘9’)

EcoSystem Integration

- *EcoSystem* ballasts and modules connect to a *GRAFIK 7000* system via *XP* relay modules, which allows *EcoSystem* ballasts to be turned on or off via a *GRAFIK 7000*. The *EcoSystem* must be set up and programmed via the *EcoSystem* Programmer
- The maximum number of *EcoSystem* ballasts or modules that may be connected on one *EcoSystem* Bus is 64. Each *EcoSystem* Bus acts independently and cannot be interconnected to other *EcoSystem* busses.

Note: Connections from *EcoSystem* to *GRAFIK 7000* is limited to switching power wiring only. No digital communication is done between the *GRAFIK 7000* system and any controlled load

Sivoia Integration

- Shade integration is via an *SO-SVC*, which allows control of a single or multiple shades; a separate *SO-SVC* is required for each shade zone
- *SO-SVC* is an output device only; it cannot communicate shade position back to the centralized lighting control Processor

Job Name:	Model Numbers:
Job Number:	