

3-Wire Control 120/277 Volt T5 HO Linear Lamps

3-Wire Control, 120/277 Volt T-8 and T-12 Linear Lamps



1.18" w (30mm) x 1.00" h (25mm) x 18.00" l (457mm)

2.38" w (60mm) x 1.50" h (38mm) x 9.50" l (241mm)

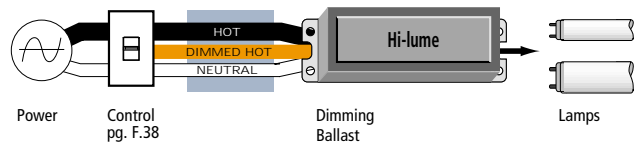
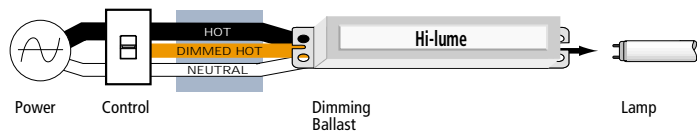

DESCRIPTION

- Continuous, flicker-free, 100%-1% dimming to meet the needs of the most demanding architectural lighting designs
- 1" high ultra-slim, low-profile design for demanding low-profile fixture applications
- 3-wire line-voltage control technology for most consistent fixture-to-fixture dimming performance
- Low harmonic distortion throughout entire dimming range to maintain power quality
- Inrush current limiting circuitry to eliminate circuit breaker tripping, switch arcing, and relay failure
- End-of-lamp-life protection circuitry helps ensure safe operation throughout entire lamp life cycle
- Lamps turn on at any dimmed level without flashing to full light to eliminate nuisance flashing
- Miswire protection to eliminate potential failures caused by improper installation
- 100% performance tested prior to shipment
- 3-Year warranty
- Optional field service commissioning available – extends warranty to 5 years (limited)
- Designed and assembled in the USA.
- Ultra quiet operation

DESCRIPTION

- Continuous, flicker-free, 100%-1% dimming to meet the needs of the most demanding architectural lighting designs
- 3-wire line-voltage control technology for most consistent fixture-to-fixture dimming performance
- Low harmonic distortion throughout entire dimming range to maintain power quality
- Inrush current limiting circuitry to eliminate circuit breaker tripping, switch arcing, and relay failure
- Lamps turn on at any dimmed level without flashing to full light to eliminate nuisance flashing
- Miswire protection to eliminate potential failures caused by improper installation
- Ultra quiet operation
- 100% performance tested prior to shipment
- 3-Year warranty
- Optional field service commissioning available – extends warranty to 5 years (limited)
- Designed and assembled in the USA.

| | |
|--|------------------------------|
| <p>JOB NAME:</p> <p>JOB NUMBER:</p> | <p>MODEL NUMBERS:</p> |
|--|------------------------------|

PERFORMANCE

- Dimming range: 100% - 1%
- T8 and T12 Ballast factor greater than .85
- T5 HO Ballast factor equal to 1.0
- Total harmonic distortion less than 10%
- Power factor greater than .95
- Lamp current crest factor less than 1.7
- No visible lamp flicker
- Class A sound rating
- Continuous ballast case operating temperature 75°C
- Minimum lamp starting temperature 10°C

STANDARDS





- UL listed, CSA approved, Class P thermally protected
- Meets ANSI C82.11 High Frequency Ballast Standard
- Meets FCC EMI/RFI emission requirements for commercial applications
- Meets ANSI C62.41 Category A surge protection standards
- ISO 9001 Certified

JOB NAME:

JOB NUMBER:

MODEL NUMBERS:

HI-LUME BALLASTS

| LAMPS | | | 120 VOLTS | | 277 VOLTS | |
|--|---|----------------------|---------------------------------|-----------------------------|---------------------------------|-------------------------|
| | WATTS/ LENGTH | LAMPS PER BALLAST | BALLAST CURRENT ¹ | HI-LUME MODEL NUMBER | BALLAST CURRENT ¹ | HI-LUME MODEL NUMBER |
| T5 LINEAR HO HIGH OUTPUT^{3,4}  5/8" Diameter | 54W/45.3" | 1 | .57A | FDB-T554-120-1 | .25A | FDB-T554-277-1 |
| | | 2 | 1.05A | FDB-T554-120-2 | .45A | FDB-T554-277-2 |
| T8 LINEAR AND U-TUBE  1" Diameter | 17W/24" | 1 | .19A | FDB-2427-120-1 | .08A | FDB-2427-277-1 |
| | | 2 | .31A | FDB-2427-120-2 | .15A | FDB-2427-277-2 |
| | | 3 | .43A | FDB-2427-120-3 | .20A | FDB-2427-277-3 |
| | 25W/36" | 1 | .24A | FDB-3627-120-1 | .12A | FDB-3627-277-1 |
| | | 2 | .43A | FDB-3627-120-2 | .19A | FDB-3627-277-2 |
| | | 3 | .62A | FDB-3627-120-3 | .28A | FDB-3627-277-3 |
| | 32W/48" | 1 | .30A | FDB-4827-120-1 | .14A | FDB-4827-277-1 |
| | | 2 | .57A | FDB-4827-120-2 | .25A | FDB-4827-277-2 |
| | | 3 | .82A | FDB-4827-120-3 | .35A | FDB-4827-277-3 |
| | 40W/60" | 1 | .36A | FDB-6027-120-1 | .16A | FDB-6027-277-1 |
| | | 2 | .64A | FDB-6027-120-2 | .30A | FDB-6027-277-2 |
| | T12 LINEAR AND U-TUBE  1-1/2" Diameter | 30W/36" | 1 | .34A | FDB-3643-120-1 | .14A |
| | | 2 | .55A | FDB-3643-120-2 | .25A | FDB-3643-277-2 |
| 40W/48" | | 1 | .39A | FDB-4843-120-1 | .17A | FDB-4843-277-1 |
| | | 2 | .70A | FDB-4843-120-2 | .30A | FDB-4843-277-2 |
| T12 LINEAR HO (HIGH OUTPUT)  1-1/2" Diameter | 45W/36" | 1 | .43A | FDB-3680-120-1 ² | | |
| | 60W/48" | 1 | .56A | FDB-4880-120-1 ² | | |
| | 85W/72" | 1 | .75A | FDB-7280-120-1 ² | | |
| | 100W/84" | 1 | .83A | FDB-8480-120-1 ² | | |
| | 110W/96" | 1 | .88A | FDB-9680-120-1 ² | | |

¹ For maximum number of ballasts per control, divide the control's current capacity by the individual ballast current.

² High output ballasts for use with T12 lamps that have an operating current of 800mA.

³ Dims T5 High Output (HO) linear lamps only; does not dim standard T5 linear lamps.

⁴ Lamp length and pin spacing differ from T8 linear lamps.



| | |
|--|-----------------------|
| JOB NAME: JOB NUMBER: | MODEL NUMBERS: |
|--|-----------------------|

T5 HO LINEAR LAMP MODELS

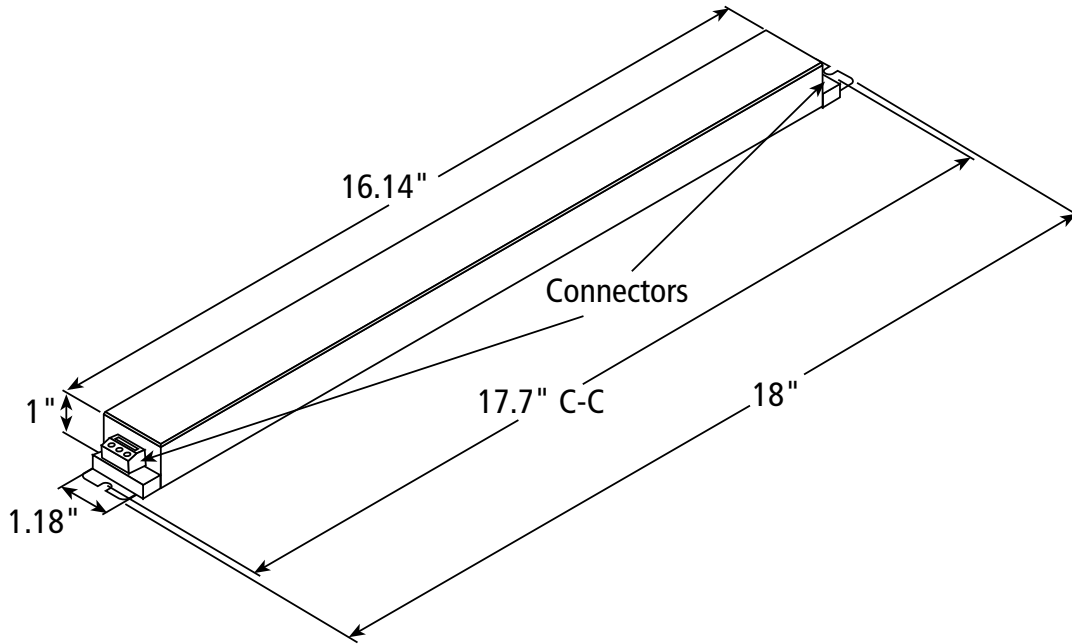

HI-LUME® LINEAR LAMP MODELS

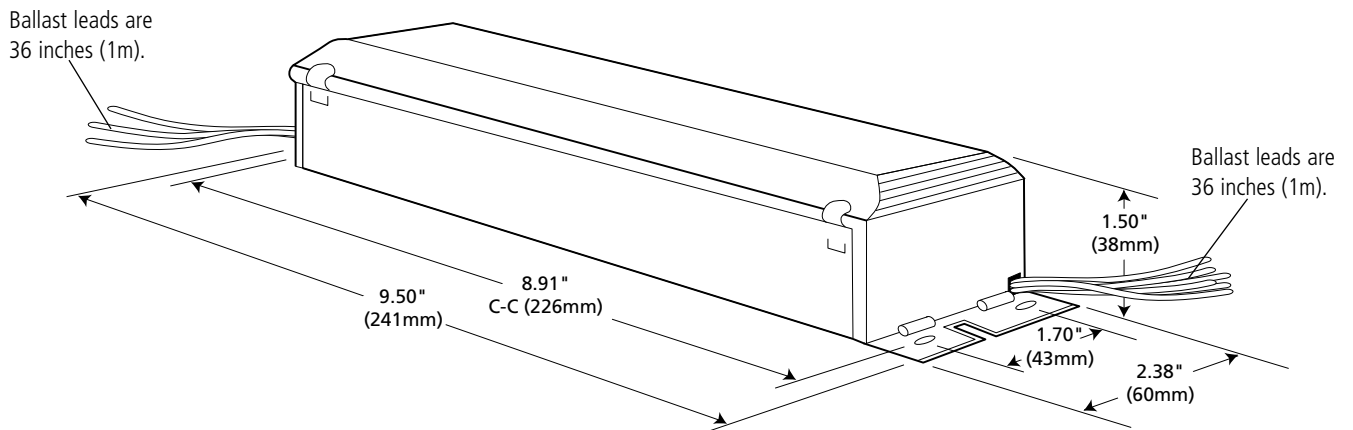

Note: For T5-HO, T8 and T12 linear lamps, maximum lamp to ballast wire length is 7 feet (2m). For T4 Compact and T5 Twin Tube lamps, maximum lamp to ballast wire length is 3 feet (1m).

LUTRON® SPECIFICATION SUBMITTAL

Page

| | |
|---------------------------|------------------------------|
| <p>JOB NAME:</p> | <p>MODEL NUMBERS:</p> |
| <p>JOB NUMBER:</p> | |

BALLAST WIRING

Note: Wire colors shown are for Lutron controls and ballasts only.

Note: For T5-HO, T8 and T12 linear lamps, maximum lamp to ballast wire length is 7 feet (2m). For T4 Compact and T5 Twin Tube lamps, maximum lamp to ballast wire length is 3 feet (1m).

One Lamp

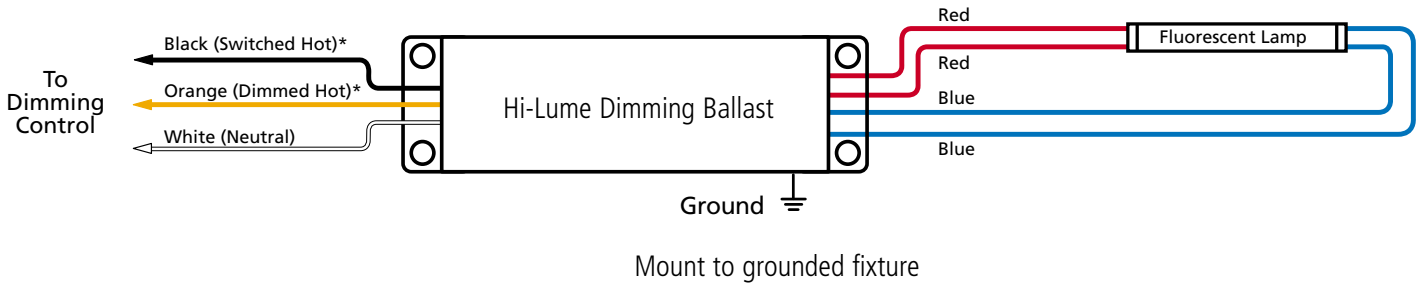

Two Lamps

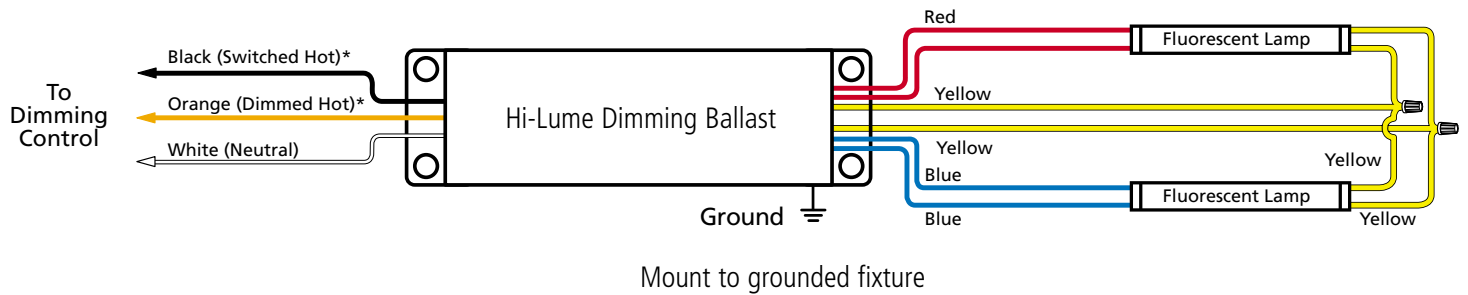

Three Lamps

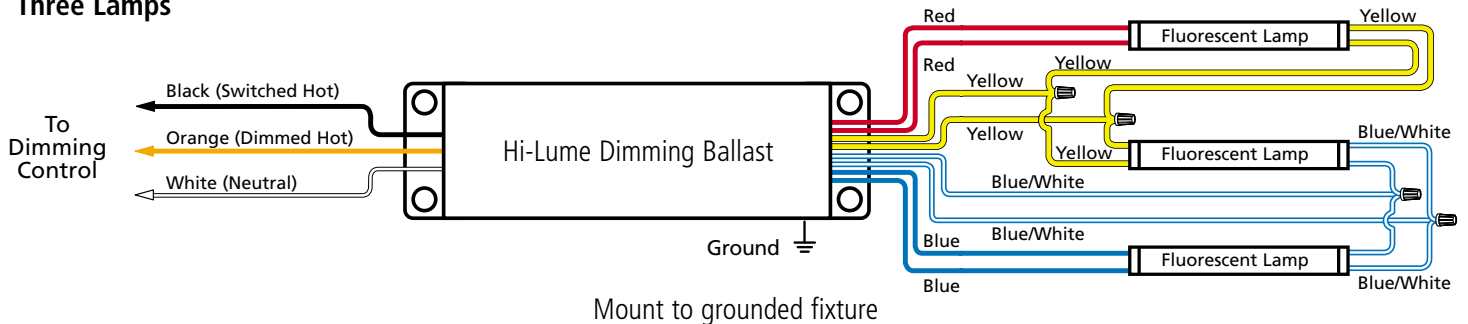

*Control wire colors do not necessarily match ballast wire colors (e.g. control "dimmed hot" may be yellow and ballast "dimmed hot" may be orange).

| | |
|--|------------------------------|
| <p>JOB NAME:</p> <p>JOB NUMBER:</p> | <p>MODEL NUMBERS:</p> |
|--|------------------------------|

APPLICATION NOTES

Perceived vs. Actual Light

An important aspect of lighting control is the difference between measured and perceived light levels. For example, a light dimmed to 10% output is perceived by the eye as 32%. A light dimmed to 1% is perceived as 10%. This "Square Law" phenomenon takes advantage of how the human eye functions to achieve significant energy savings, while improving the visual environment.

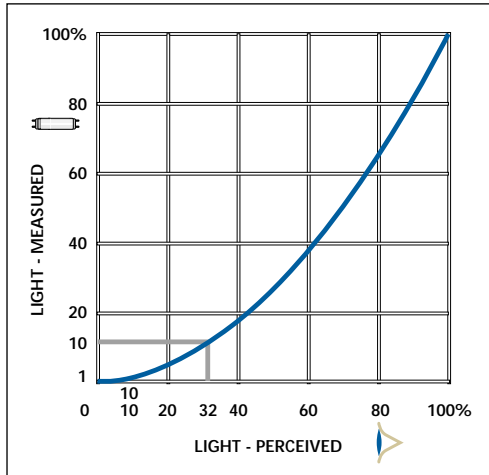

Power vs. Light

The nearly linear relationship between fluorescent light levels and power consumption saves energy proportionately as lights are dimmed.

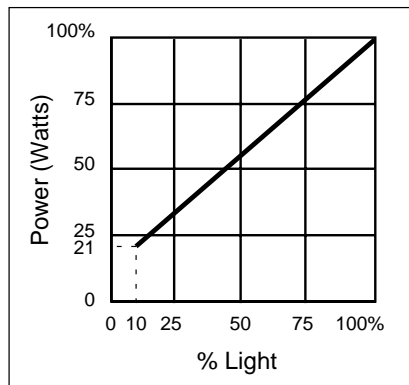

SPECIFICATIONS

Rapid-Start Sockets Must Be Used

Rapid-start type sockets must be used to provide proper lamp filament heating and dimming operation.

Quality knife-edge sockets are recommended for new and retrofit applications to ensure positive lamp/pin contact.

Mixing Ballast and Lamps per Circuit

For optimal dimming performance, do not mix ballast lamp types (T4, T5, T8, or T12) on a given circuit. Mixing lamp lengths (48", 36", 24" etc.) within a single lamp type is permissible and will not diminish dimming performance.

Do not mix ballast types on a given circuit (i.e., mix Hi-lume with Eco-10 or Tu-Wire).

Number of Ballasts per Control

For maximum number of ballasts per control, divide control's current capacity by the individual ballast current. Certain controls also a specific number of stated ballast maximums.

JOB NAME:

MODEL NUMBERS:

JOB NUMBER:

INSTALLATION

Ballast/Socket Leads

Lead lengths from electronic dimming ballast to socket must not exceed 7' (2m) for T5, T8, and T12 linear lamps.

Lamp Mounting

Many fluorescent lamp sockets are available with mounting slots to vary the height of the lamp away from the grounded metal surface. Use these slots to get the outside edge of the lamp to be 1/2" +/- 1/4" away from the grounded metal surface.

Having a fluorescent lamp too close to the grounded metal will make the minimum intensity too low and will reduce lamp life.

Having a fluorescent lamp too far away from the grounded metal will make the lamp flicker or not turn on at all.

Wiring and Grounding

All wiring from the dimming control to the Hi-lume® Ballasts is Class 1 and may be run together in the same conduit.

Ballast and lighting fixture must have a positive electrical contact with ground.

Ballasts must be installed per national and local electrical codes.

PERFORMANCE

Lamps Must Be Seasoned

New Lamps must be operated ("seasoned") for 100 hours at full light output prior to dimming to achieve proper dimming performance and ensure average rated lamp life.

Ballast Operating Temperature

Ballast case temperature must not exceed 75°C at any point on ballast.

SERVICE

Replacement Parts

Use replacement parts with exact Lutron model numbers. Consult Lutron if you have any questions.

Further Information

Ballasts for other lamp types and voltages may be available; consult Lutron for further information.

For further information on dimming ballast applications, consult Lutron's Ballast Fluorescent Dimming Systems Guide (publication 366-606).

| | |
|--------------------|-----------------------|
| JOB NAME: | MODEL NUMBERS: |
| JOB NUMBER: | |