

HOMEWORKS™ Remote Power Module

HW-RPM-4U -230-CE

LUTRON SPECIFICATION SUBMITTAL

Job Name		Job Number
Location		Zones Controlled
Model No. HW-RPM-4U-230-CE		
Zone No.	Description	Load
1		
2		
3		
4		

4 Zone Dimming/ Switching Module

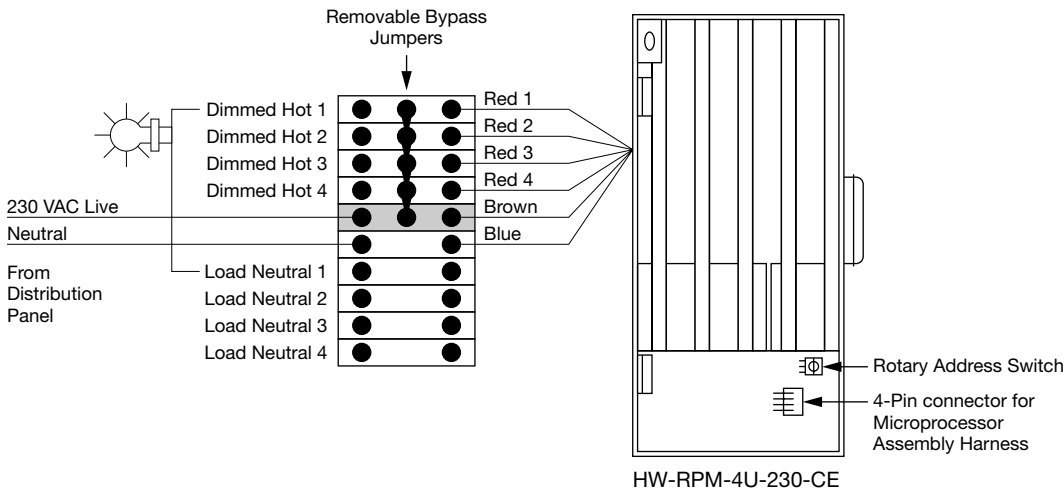

Specifications

Input Feed	220/240 VAC 50/60 Hz, 13 amps
Module Rating	220/240 VAC, 13 amps (2990 VA at 230V)
Zone Capacity	220/240 VAC, 10 amps (2300 VA at 230V) maximum for each zone
Load Types Capacity	Incandescent, Electronic Low-Voltage, Neon/Cold Cathode, Magnetic Low Voltage, Fluorescent (non-dim)

Function

The remote power module is a component of the HomeWorks system. It is used to control up to 4 zones of lighting, each of which may be dimmable. The remote power module mounts inside a pre-assembled remote power panel, in one of eight (8) possible locations. Each RPM has a dedicated terminal block which provides wiring connection facilities for input feed and 4 controllable output circuits.

Terminal Blocks handle 8 Remote Power Modules (RPMs), with capacity of 4 Zones Per Module

RPM Module Locations (8 Maximum Per Panel)

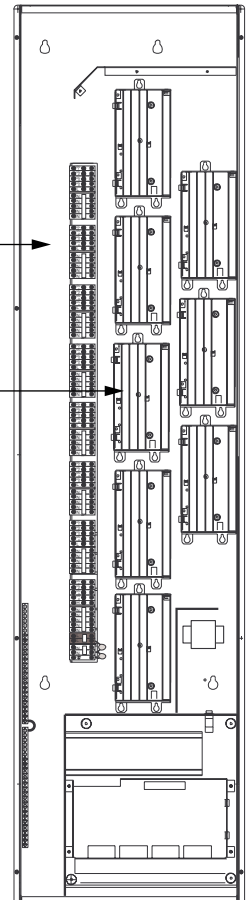

Pre-Assembled Remote Power Panel



Lutron Electronics Co., Inc.
7200 Suter Road
Coopersburg, PA 18036, USA
7/98 P/N 366-761/A4

For additional submittal sheets, call our Hotline and Fax-on-Demand Service at 1-800-523-9466, or visit Lutron's Web site at <http://www.lutron.com/resi>



Overview of HomeWorks Integrated System

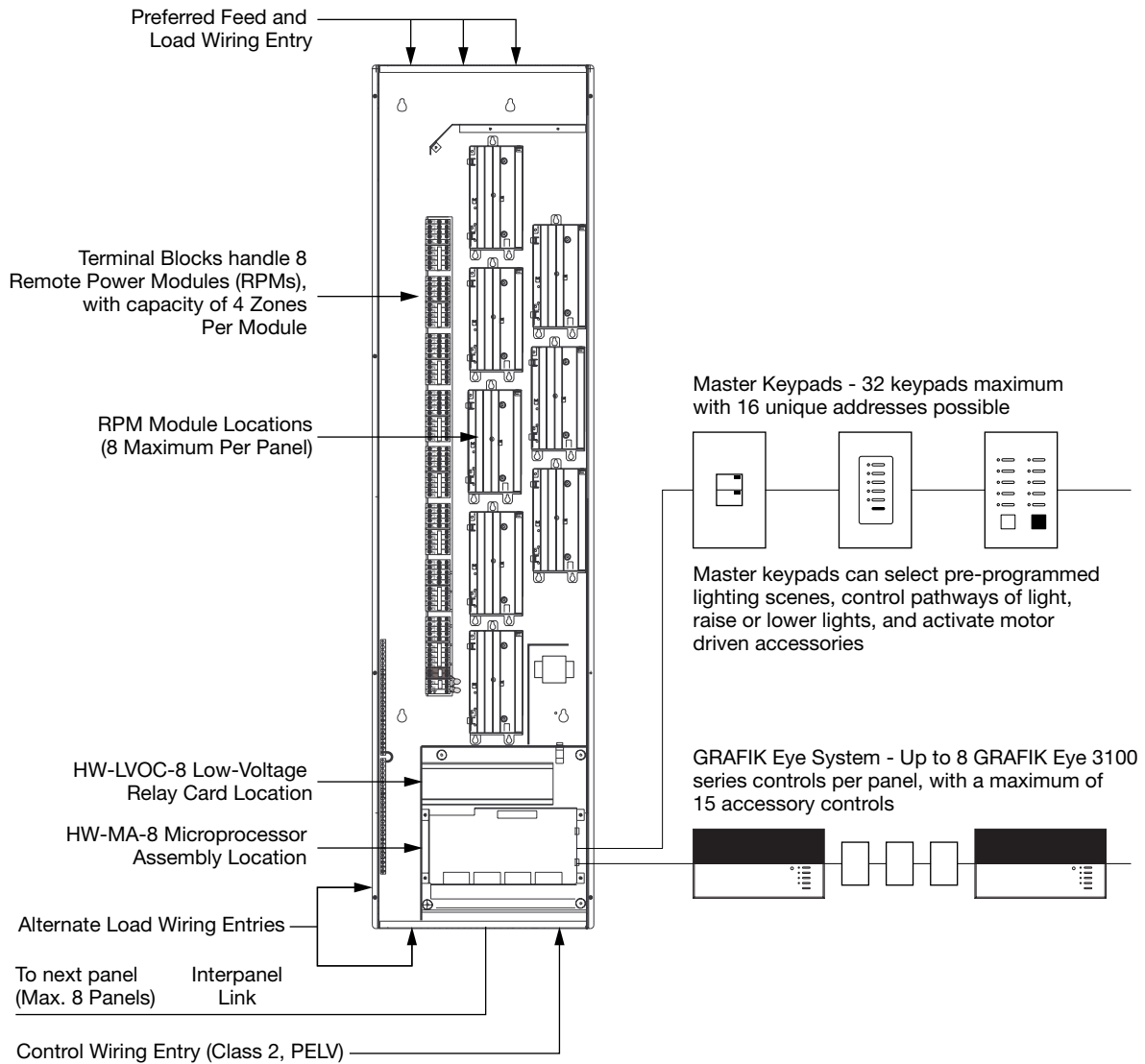

Addressing

Each module has a rotary address switch which is set to match the module's position in the remote power panel.

Diagnostics

Each module has a diagnostic LED which can be used to test each of the module's outputs. Additional diagnostics can be performed with the HomeWorks Windows-based software.

Warranty

Lutron will, at its option, repair or replace any control that is defective in materials or manufacture within two years after the purchase.

This warranty is in lieu of any other warranties, express or implied, and the implied warranty of merchantability is limited to two years from purchase.

This warranty does not cover the cost of installation, removal or reinstallation, or damage resulting from misuse, abuse, or improper wiring or insulation.

This warranty gives you specific legal rights, and you may also have other rights which vary from state to state. Some states do not allow the exclusion or limitation of incidental or consequential damages, or limitations on how long an implied warranty may last, so the above limitations and exclusions may not apply to you.

Printed in U.S.A.

© 1998 Lutron Electronics Co., Inc.