

Dual Technology Wall Mount Occupancy Sensor



The LOS-WDT Series wall-mount dual-technology sensors are used to control lighting in spaces that have pendant fixtures, ceiling fans, or high ceilings (more than 12 ft./ 3.7 m), where ceiling-mount occupancy sensors would not function reliably. The adaptive technology eliminates manual sensitivity and timer adjustments during installation and over the life of the product.

Features

- Intelligent, continually adapting sensor
- Ultrasonic (US) combined with passive infrared (PIR) sensing provide high sensitivity, high noise immunity, and excellent false tripping immunity
- Suited for complex environments that are difficult to control with single-technology sensors
- Flexible base mounting on wall or ceiling
- Aim and lock: base mount permits fast alignment
- Non-Volatile Memory: settings saved in protected memory are not lost during power outages
- 1600 sq.ft. (488 m²) of coverage when used where the ceiling height is between 8 - 12 ft. (2.4 - 3.7 m)
- Affords choice of turning lights off or dimming to a preset level in the unoccupied state when integrated with a Lutron system.

Models Available

| Cat. No. | Color | Coverage | Field of View |
|--------------|-------|-----------------------------------|---------------|
| LOS-WDT-WH | White | 1600 sq.ft. (488 m ²) | 110° |
| LOS-WDT-R-WH | White | 1600 sq.ft. (488 m ²) | 110° |

Self-Adaptive Feature

The LOS-WDT Series wall-mount occupancy sensors combine both ultrasonic (US) motion detection for maximum sensitivity and passive infrared (PIR) motion detection for false triggering immunity. The self-adapting internal microprocessor analyzes the composite sum of both signals to eliminate time-consuming adjustments and callbacks found in non-intelligent sensors.

| | |
|--------------------|-----------------------|
| Job Name: | Model Numbers: |
| Job Number: | |

Specifications

Timer Settings

- Automatic mode: Continually adapting sensor automatically adjusts settings to the space
- Manual mode: 4 to 30 minutes
- Test mode: 8 seconds

LED Lamp

- Red: infrared motion
- Green: ultrasonic motion

Housing

- High-impact, injection molded plastic housing
- 6 in. (15 cm) color-coded lead wires

Power

- Operating voltage: 20 - 24 V $\overline{=}$, Class 2 (PELV) low-voltage
- Operating current: 33 mA nominal
- Control output: 20 - 24 V $\overline{=}$ active high logic control signal with short-circuit protection, open collector when unoccupied
- UL and CUL listed

Operating Environment

- Temperature: 32 to 104 °F (0 to 40 °C)
- Relative humidity: 0% to 95%, non-condensing
- For indoor use only

Contact Rating (R Models only)

- SPDT 500 mA rated at 24 V $\overline{=}$ isolated relay

Photo Cell (R Models only)

- Prevents light from turning on when there is sufficient natural light
- Sensitivity: 20 - 3,000 LUX adjustable

Dimensions

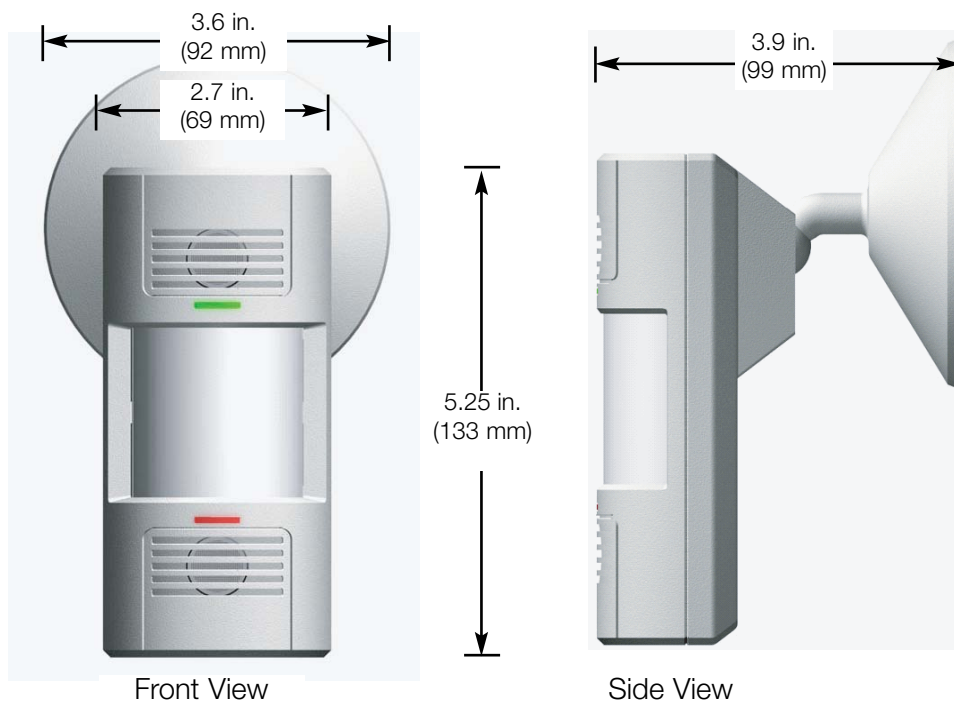

Job Name:

Model Numbers:

Job Number:

Wiring

Note: Power pack may be required when interfaced to lighting control system; see below.

Single Sensor to System

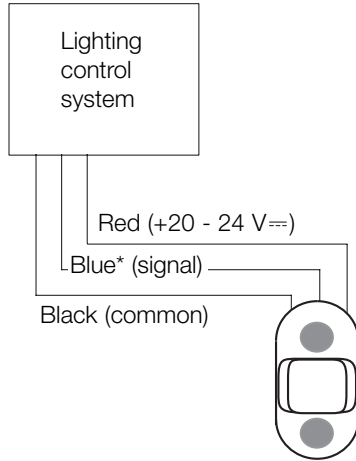

2 or More Sensors to System

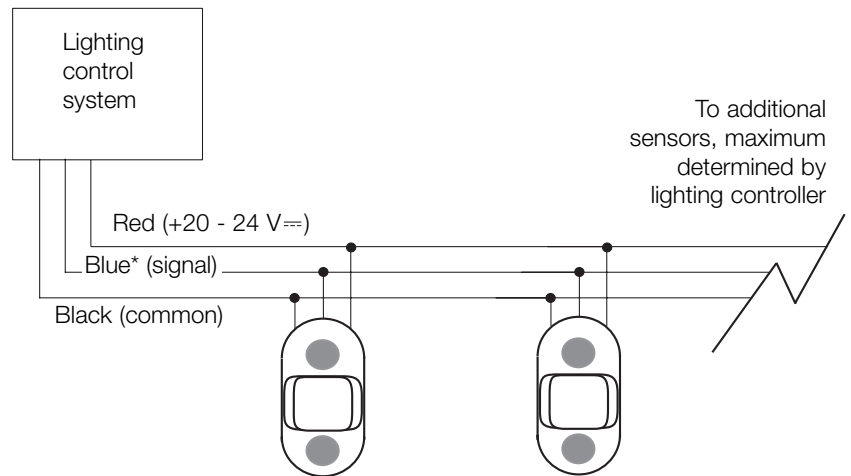

*Note: Use gray wire for -R model.

Power Supply Options

Lutron Lighting Control System

Digital microWATT™

EcoSystem®

GRAFIK 5000 / 6000 / 7000

GRAFIK Eye® 3000 / 4000

HomeWorks®

LCP128™

microWATT®

RadioRA®

RadioTouch®

Softswitch128®

Power Pack Required?

No

No

No, when used with *seeTouch*® wallstations with occupant sensor connections.

Yes

Yes

No, when used with *seeTouch* wallstations with occupant sensor connections.

No

Yes

No

No, when used with *seeTouch* wallstations with occupant sensor connections.

Job Name:

Model Numbers:

Job Number:

Wiring: Stand-Alone Control

1 to 3 Sensors with Power Pack

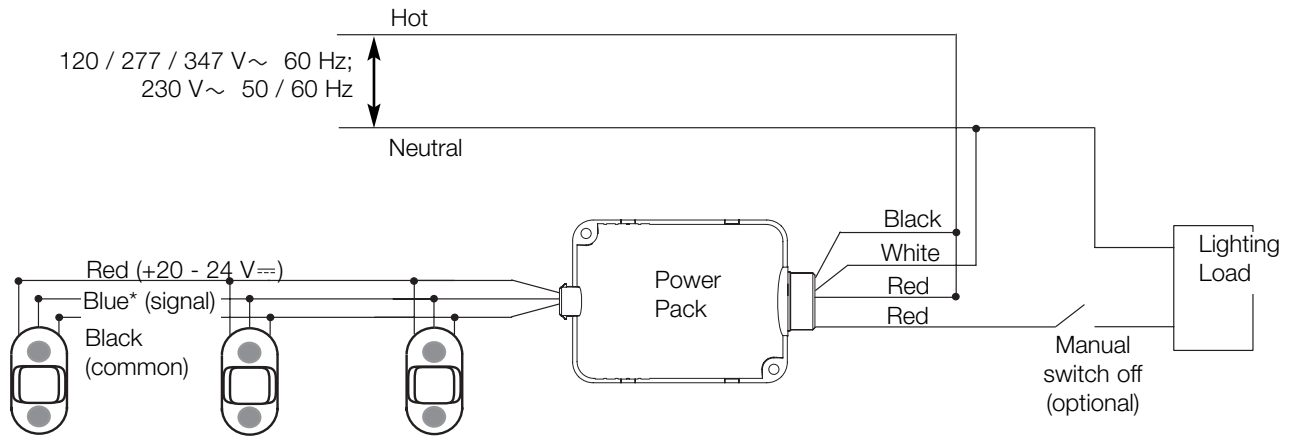

Note: Maximum 3 occupancy sensors.

Switching Multiple Loads with Auxiliary Power Packs

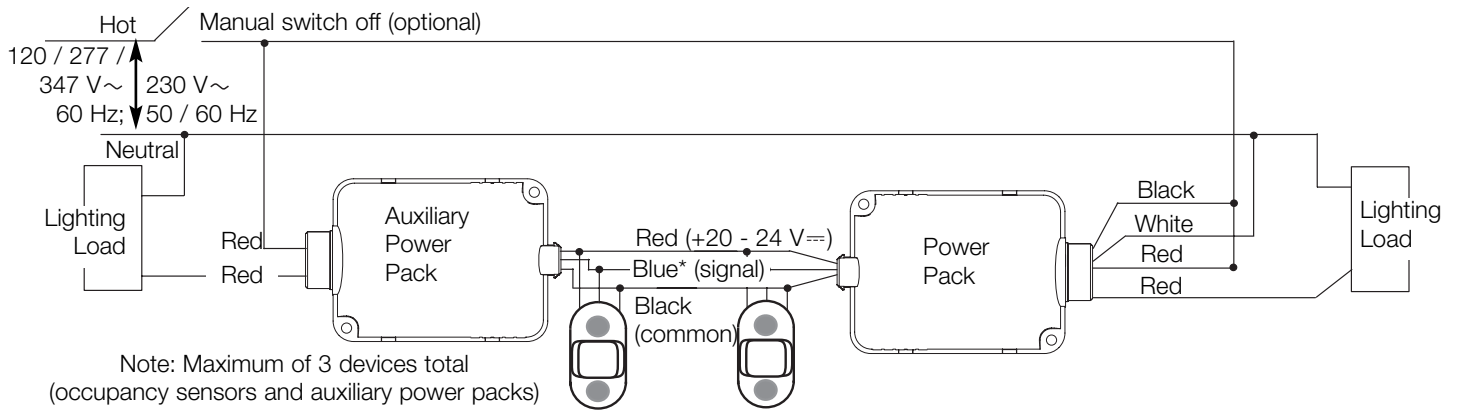

Note: Maximum of 3 devices total (occupancy sensors and auxiliary power packs) can be connected to a power pack.

*Note: Use gray wire for -R model.

| | |
|-------------|----------------|
| Job Name: | Model Numbers: |
| Job Number: | |

Wiring

Relay Model Option

LOS-WDT-R only

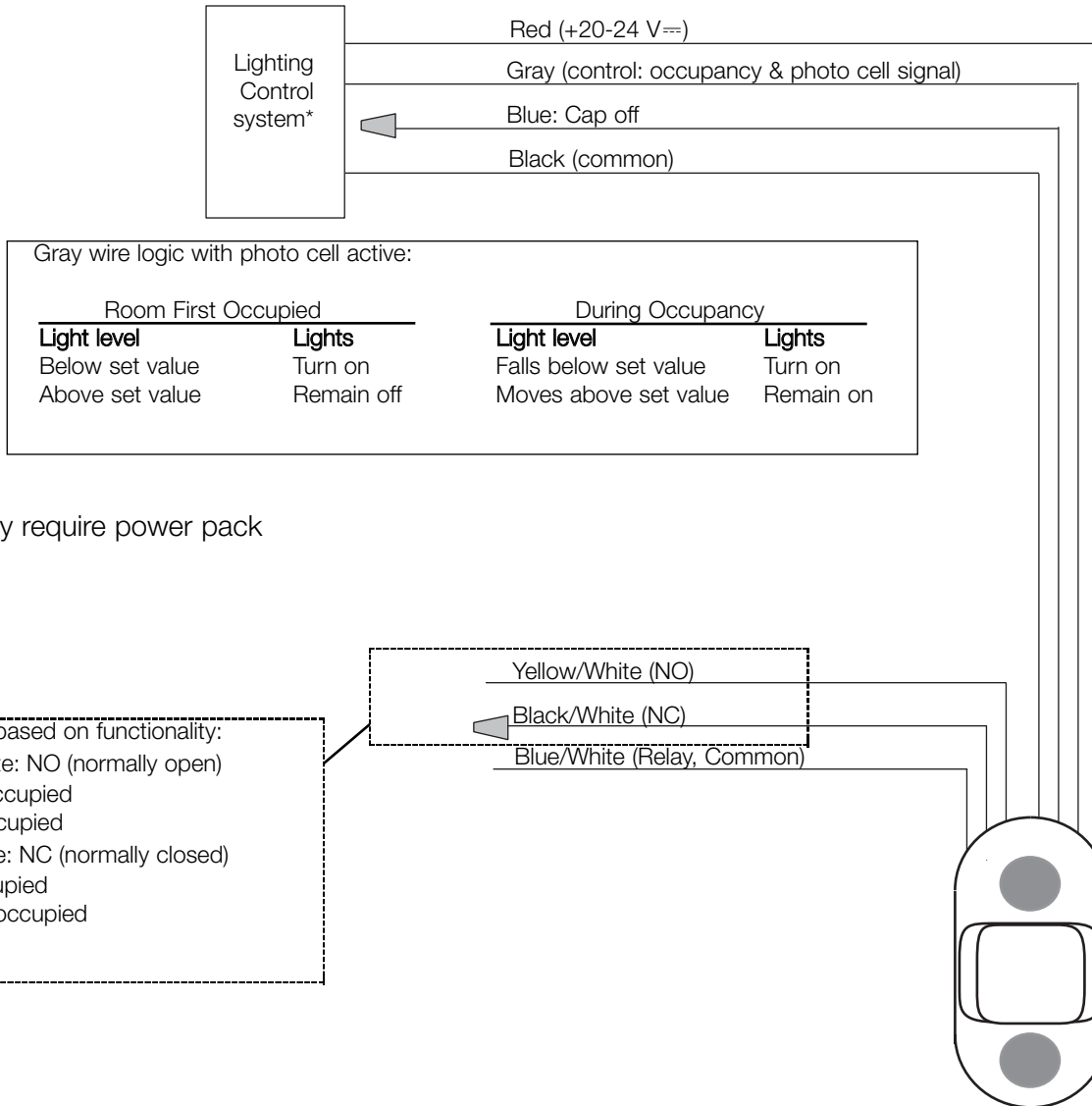

| | |
|--------------------|-----------------------|
| Job Name: | Model Numbers: |
| Job Number: | |

Installation

Sensor Placement

- The occupant sensor must have an unobstructed view of the room entrance. Do not mount behind or near tall cabinets, shelves, indirect hanging fixtures, etc.
- Keep the occupant sensor away from air flow from ventilation outlets, windows, fans, etc.
- Place the sensor on the same wall as the doorway so that traffic in a hallway will not affect the sensor.
- Closely follow the diagrams shown concerning major and minor motion coverage. The sensor can detect major motion (such as a person taking a half-step) at a greater distance than it can detect minor motion (such as writing or typing at a desk).
- Decrease total coverage area by 15% for “soft” rooms (for example, heavy draperies or heavy carpeting).

Range Diagrams

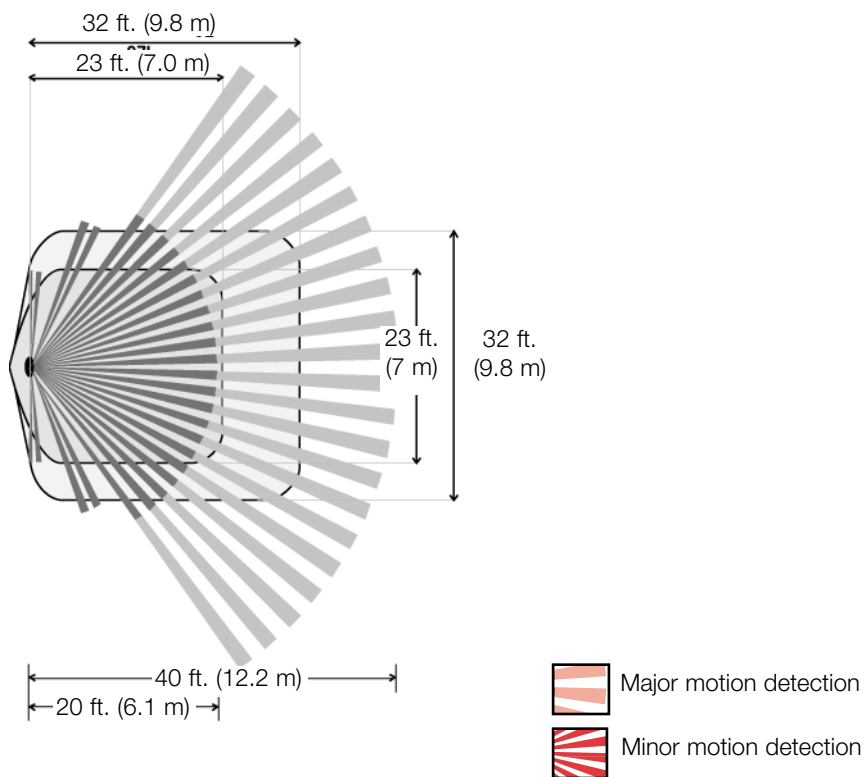

Job Name:

Model Numbers:

Job Number:

Installation

Mounting

Mounting to Wall or Ceiling Tile

Redrill wiring routing hole and (2) mounting holes using Mounting Bracket as template. Route wires through wall and mounting bracket. Secure mounting bracket to wall/ceiling tile using mounting screws, nuts, and washers (included).

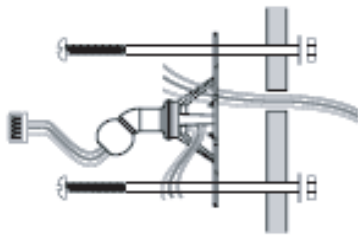

Mounting in Acoustic Ceiling Tile

Twist threaded mounting post onto Mounting Bracket. Drill through ceiling tile with assembly. Secure with washer and nut. Route wiring through Mounting Bracket and connect to wire harness. Snap bracket cover in place to conceal wiring and bracket.



Either Method

Feed wiring harness through the back of the sensor body and out the exit slot. Snap sensor onto mounting post. Plug wiring harness into connector on the left side (opposite exit slot) and place wiring under wire tabs. Align sensor and tighten position locking screw.

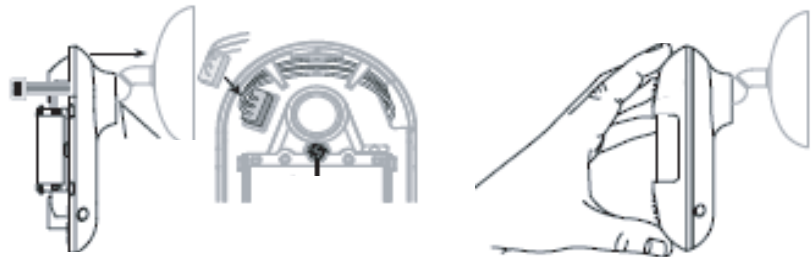

Wire Lengths

| | | | | | | |
|----------------------|----------|----------|---------|----------|---------|---------|
| # Sensors | 1 | 2 | 3 | 1 | 2 | 1 |
| # Aux. PP | 0 | 0 | 0 | 1 | 1 | 2 |
| 22 AWG | 750 ft. | 375 ft. | 250 ft. | 375 ft. | 250 ft. | 250 ft. |
| 0.5 mm ² | 365 m | 180 m | 120 m | 90 m | 120 m | 120 m |
| 20 AWG | 1200 ft. | 600 ft. | 400 ft. | 600 ft. | 400 ft. | 400 ft. |
| 0.75 mm ² | 730 m | 365 m | 240 m | 365 m | 240 m | 365 m |
| 18 AWG | 2400 ft. | 1200 ft. | 800 ft. | 1200 ft. | 800 ft. | 800 ft. |

Mounting Plate Dimensions

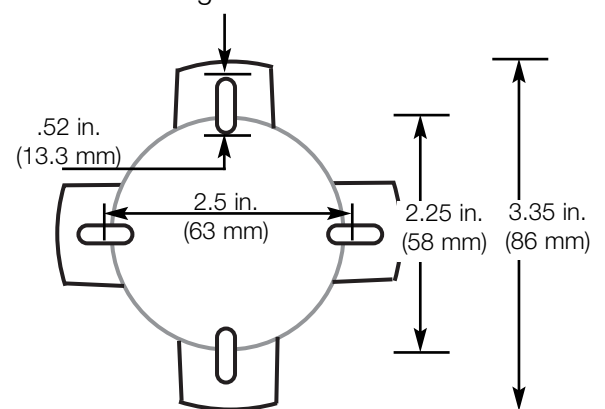

Job Name:

Model Numbers:

Job Number:

Sensor Adjustments

Override Settings

| | | Off (Default) | On |
|---|---|---|------------------------------------|
| A | 1 | <input type="checkbox"/> Automatic (Normal) | Manual lights on (Override) |
| | 2 | <input type="checkbox"/> Not used | Not used |
| | 3 | <input type="checkbox"/> LED on (Normal) | LED off |
| | 4 | <input type="checkbox"/> Retain Settings (Normal) | Any change resets learned settings |

| | | Off | | On | |
|---|---|---|------------------------------------|-------------------------------------|------------------------------------|
| B | 1 | <input type="checkbox"/> OFF } 8 | <input type="checkbox"/> OFF } 4 | <input type="checkbox"/> ON } 15 | <input type="checkbox"/> ON } 30 |
| | 2 | <input type="checkbox"/> OFF } min. | <input type="checkbox"/> ON } min. | <input type="checkbox"/> OFF } min. | <input type="checkbox"/> ON } min. |
| | 3 | <input type="checkbox"/> Auto Timer Adjust On | | Auto Timer Adjust Off | |
| | 4 | <input type="checkbox"/> Auto Sensitivity Adjust On | | Auto Sensitivity Adjust Off | |

Factory Settings

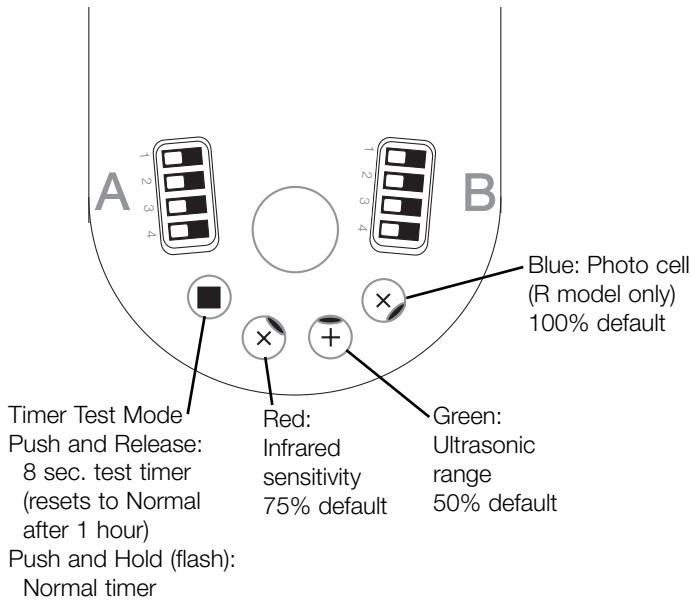

| | |
|--------------------|-----------------------|
| Job Name: | Model Numbers: |
| Job Number: | |

Installation

Adjusting the “Lights Not On” Level

LOS-WDT-R only

1. Place timer in Test Mode (see page 7).
2. Set photo cell to max.
Turn the blue knob full clockwise (lights on no matter how bright the natural light is), then 30 degrees counterclockwise.
3. Check for Lights-Out.
Move from underneath the sensor, and remain still until the lights turn off. Move around normally to turn the light on.
4. Adjust to desired level.
If lights remain off, adjust the blue knob another 30 degrees counterclockwise and repeat step 3 until the lights turn on.

Note: Set blue knob to 100% to disable photo cell functionality and leave secondary dry contact closure output functionality intact.

Control Settings (Blue Knob)

LOS-WDT-R only

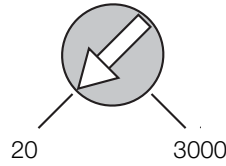

Minimum (low):
Lights will never come on, even though room is occupied.

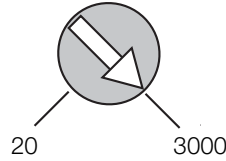

Maximum (high):
Photo cell has no effect on operation (factory setting).

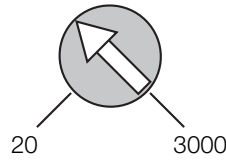

Normal:
200 to 600 LUX is normal range.

Job Name:

Model Numbers:

Job Number: